

Embedded 5G/4G Wideband SMD Antenna

W3415 - 617MHz to 6000MHz

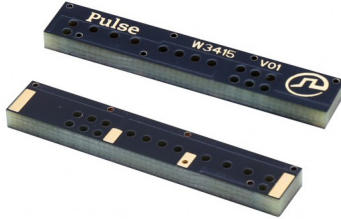

Applications:

- Ⓢ Surface Mount Compliant
- Ⓢ Broad band antenna, combines all sub 6GHz 4G and 5G bands
- Ⓢ Devices requiring high performance compact internal 4G/5G antenna
- Ⓢ Suitable for 2xMiMo use when mounting two pcs W3415 onto radio board

Electrical Specifications @ 25°C - Operating Temperature -40°C to +85°C

Frequency Bands - 617-960/1400-2690/3400-3900/4900-6000 MHz

Antenna Type	Nominal Impedance	Return Loss	Radiation Pattern	Polarization	Power Withstanding
SMT Composite	50Ω	<-4	Omni	Linear	2W
Frequency	617-960MHz	1400-1700MHz	1710-2690MHz	3400-3900MHz	4900-6000MHz
Gain	>-1dBi	>-1dBi	>2.5dBi	>2.5dBi	>2.5dBi
Efficiency	>35%	>35%	>35%	>35%	>35%

Mechanical Specifications

Size - (LxWxTh)	Color	Weight	Material	MSL	Fixing System
40mm x 7mm x 3mm	Black	1.65grms	Composite	3	SMT

Notes:

1. Storage Temperature: -40C to 85C
2. Application note is available upon request

Mechanical

W3415

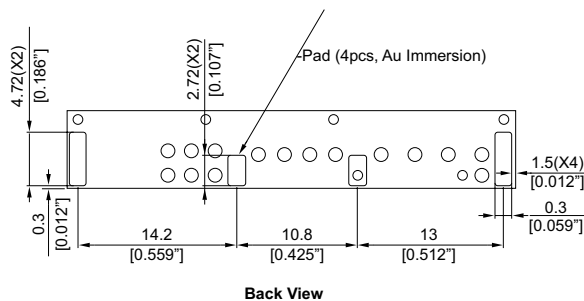
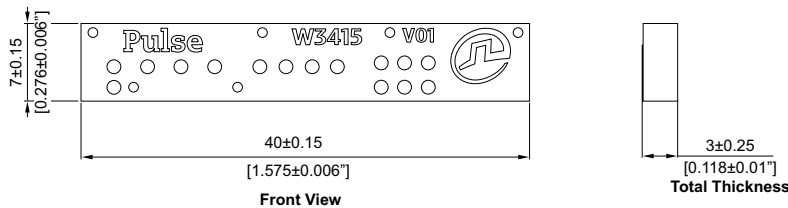

Weight1.65 grams

Tape & Reel1000/Reel

Dimensions: Inches
mm

Unless otherwise specified,
all tolerances are ± $\frac{.010}{0,25}$

Embedded 5G/4G Wideband SMD Antenna

W3415 - 617MHz to 6000MHz

PACKAGING

W3415

1000pcs Antennas Per 1pcs 13" Tape & Reel
2 pcs 13" Tape & Reel (total 2000pcs Antennas) per 1 box

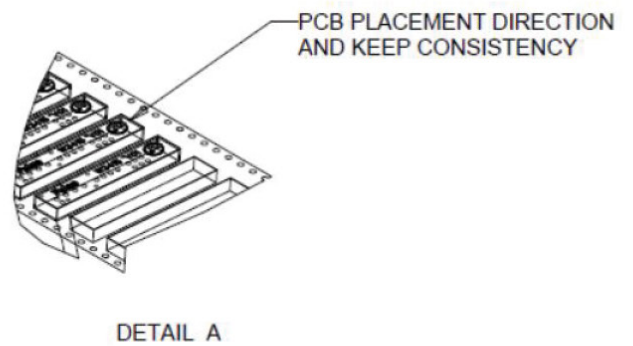
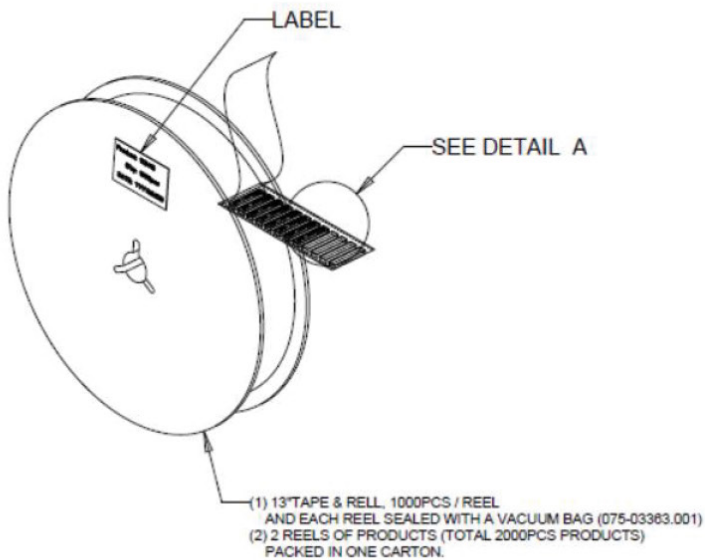
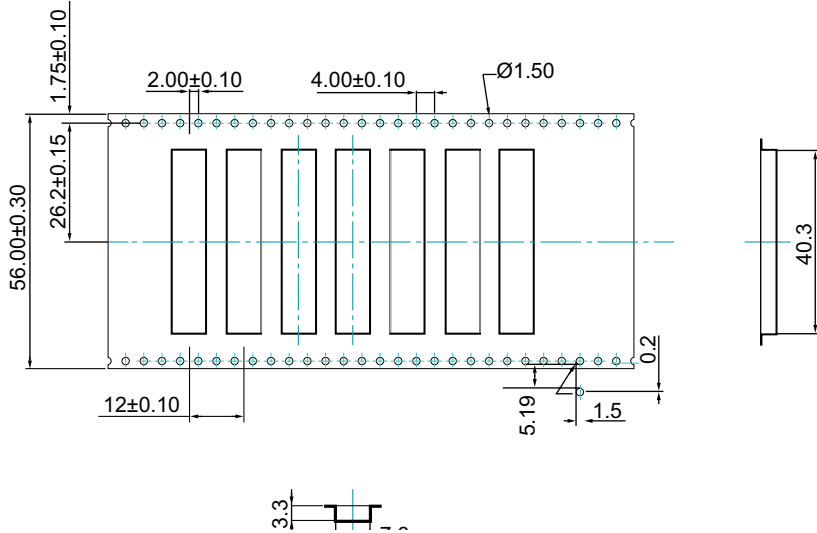

Embedded 5G/4G Wideband SMD Antenna

W3415 - 617MHz to 6000MHz

Recommendation for reflow soldering process

W3415

Printing stencil thickness 0,15-0,25 mm is recommended for the solder paste. The maximum soldering temperature should not exceed 260°C. The temperature profile recommendations for reflow soldering process is presented in the Figures 1 and

2. The reflow profile presented in figure 1 describes minimum reflow temperatures. The reflow profile presented in figure 2 describes maximum reflow temperatures located at the center of the coverage area.

Method of heat transfer		Controlled hot air convection
1	Average temperature gradient in preheating	2.5 °C/s
2	Soak time	2-3 minutes
3	Max temperature gradient in reflow	3 °C/s
4	Time above 217°C	Max 30 sec.
5	Peak temperature in reflow	230 °C for 10 seconds
6	Temperature gradient in cooling	Max -5 °C/s

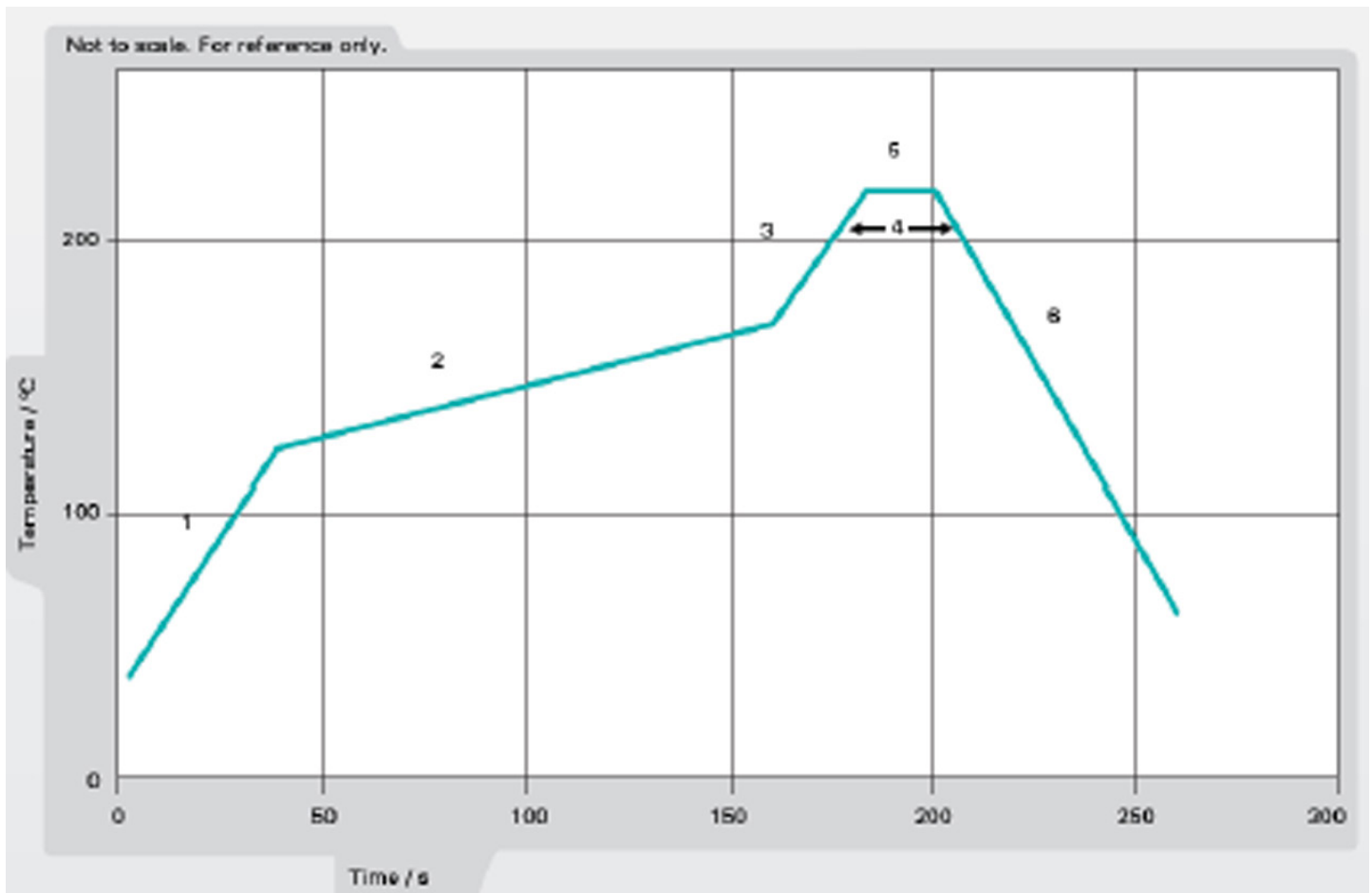

Figure 1. Minimum temperature profile recommendation for reflow soldering process

Embedded 5G/4G Wideband SMD Antenna

W3415 - 617MHz to 6000MHz

Test Setup

W3415



Embedded 5G/4G Wideband SMD Antenna

W3415 - 617MHz to 6000MHz

Test Setup

W3415

Pulse reference test PCB for W3415 antenna

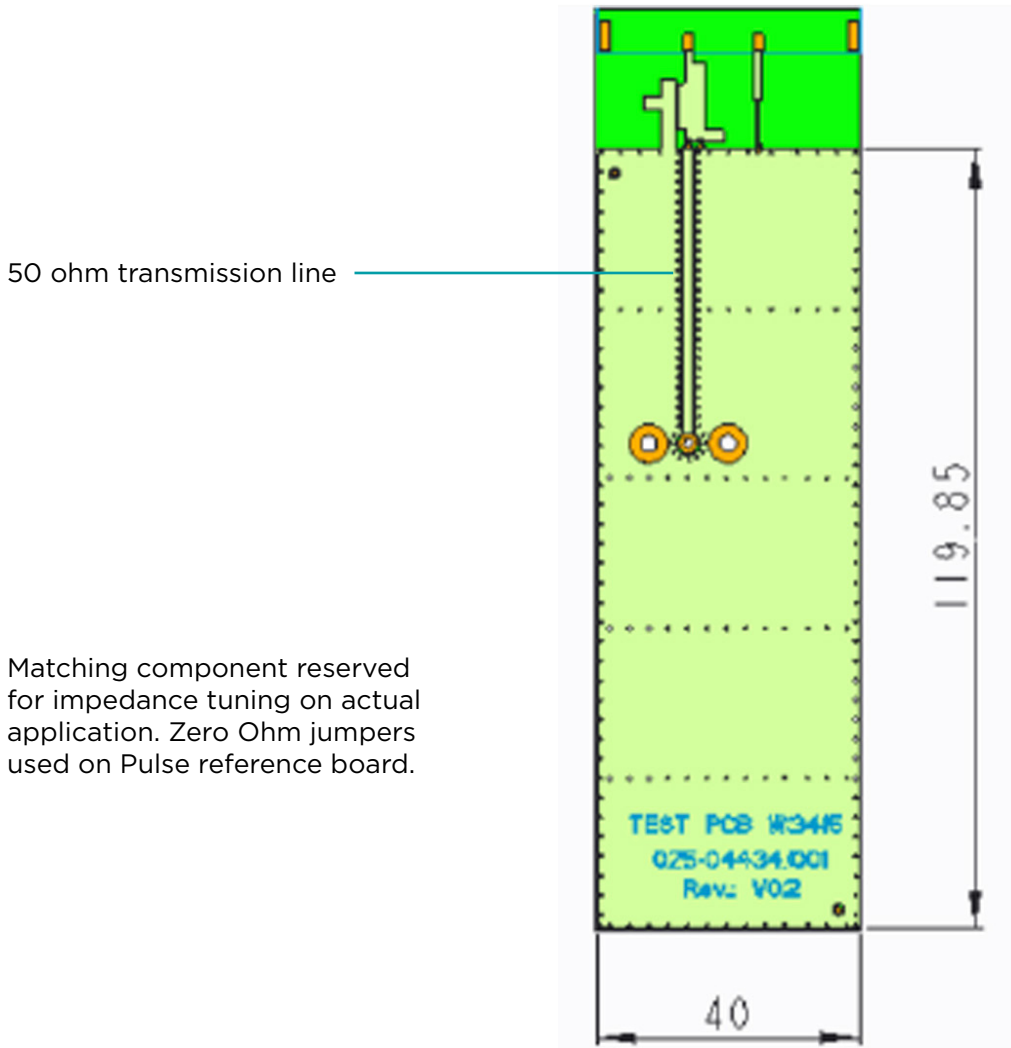

Matching component reserved for impedance tuning on actual application. Zero Ohm jumpers used on Pulse reference board.

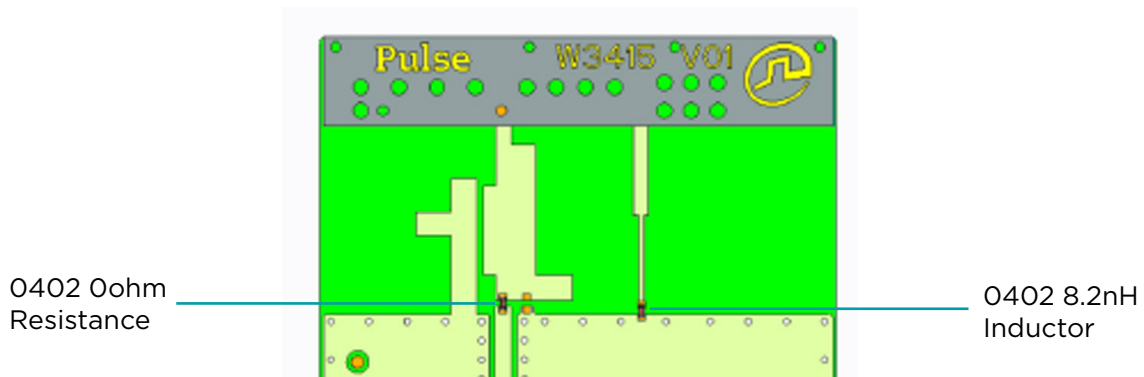

Embedded 5G/4G Wideband SMD Antenna

W3415 - 617MHz to 6000MHz

Test Setup

W3415

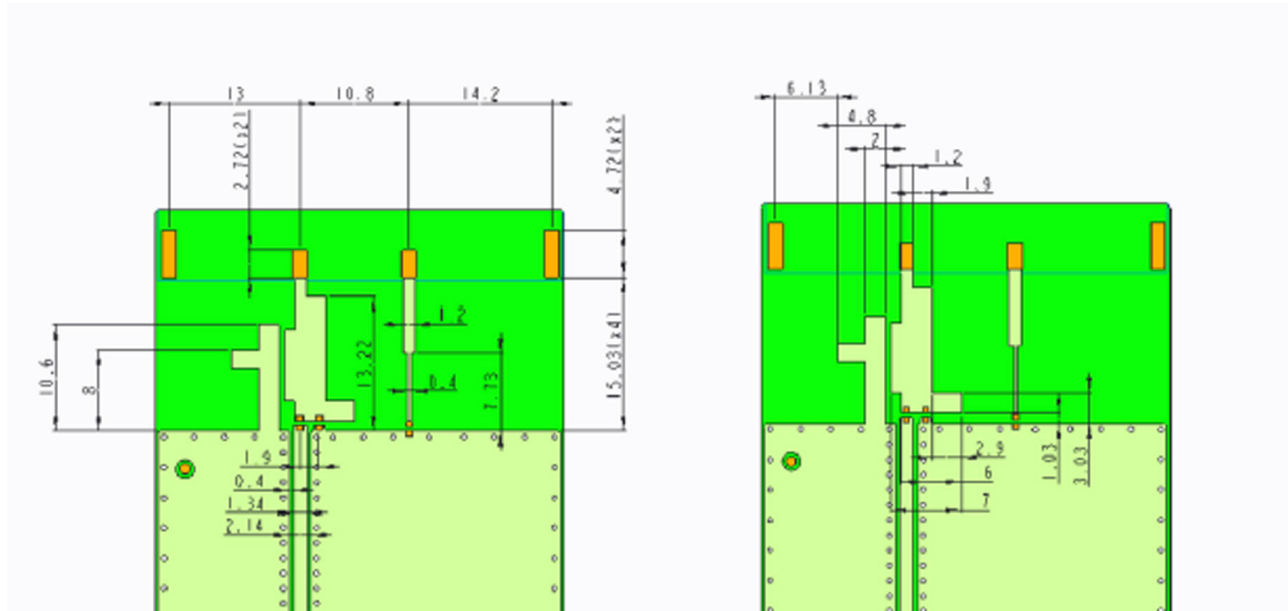

Recommended test board PCB layout for electrical characteristic measurement.

Substrate material: ISOLA 185HR.

Total thickness: 1mm

All dimensions are in mm

Charts

W3415

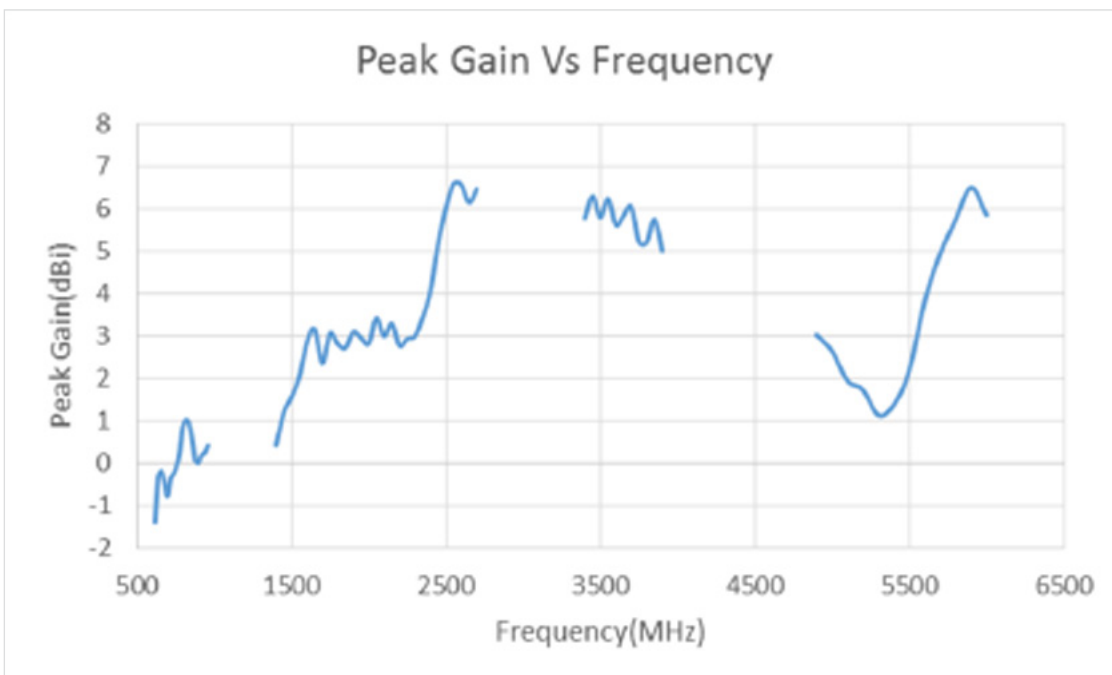
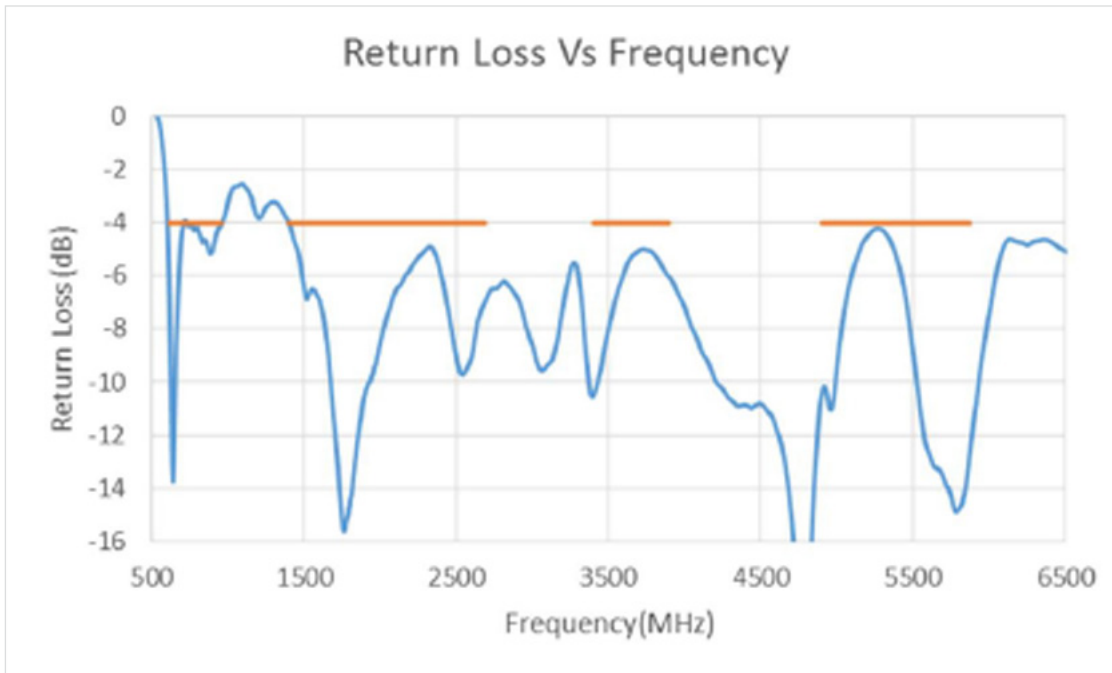

Embedded 5G/4G Wideband SMD Antenna

W3415 - 617MHz to 6000MHz

Charts

W3415

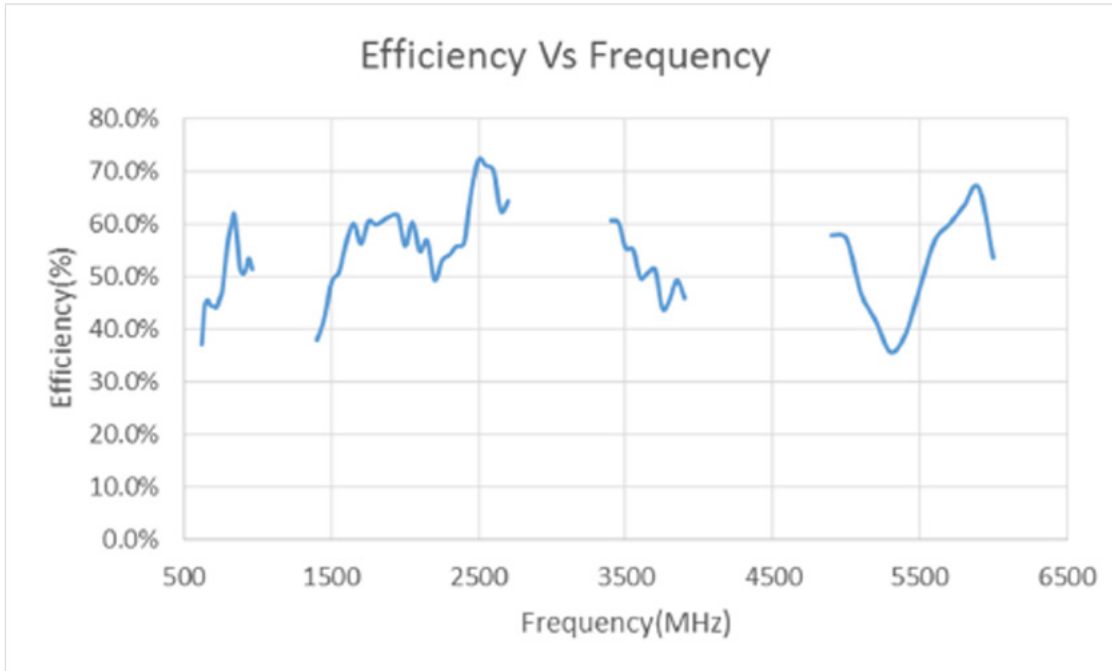

Embedded 5G/4G Wideband SMD Antenna

W3415 - 617MHz to 6000MHz

Charts

617MHz - 960MHz

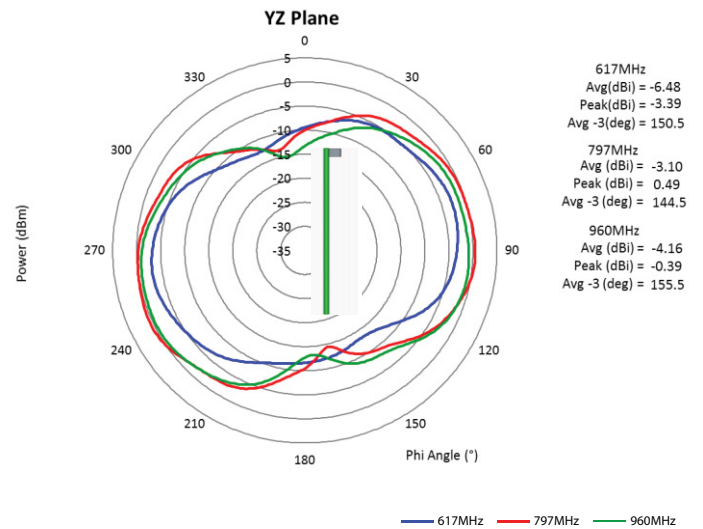
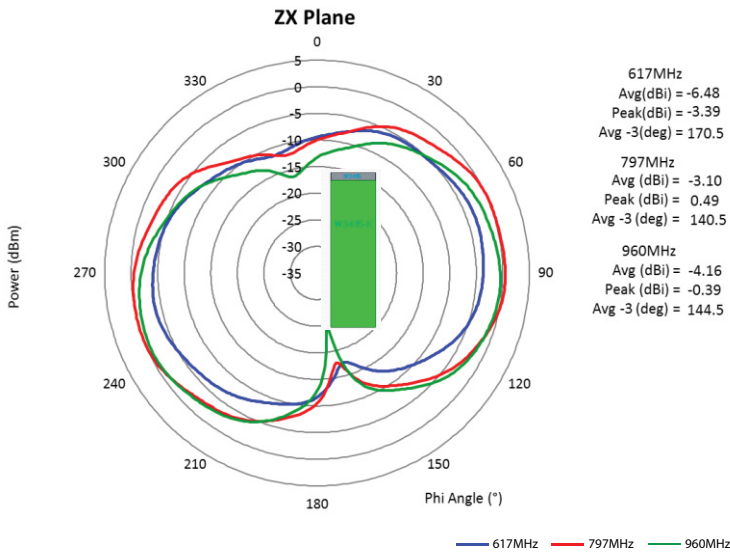
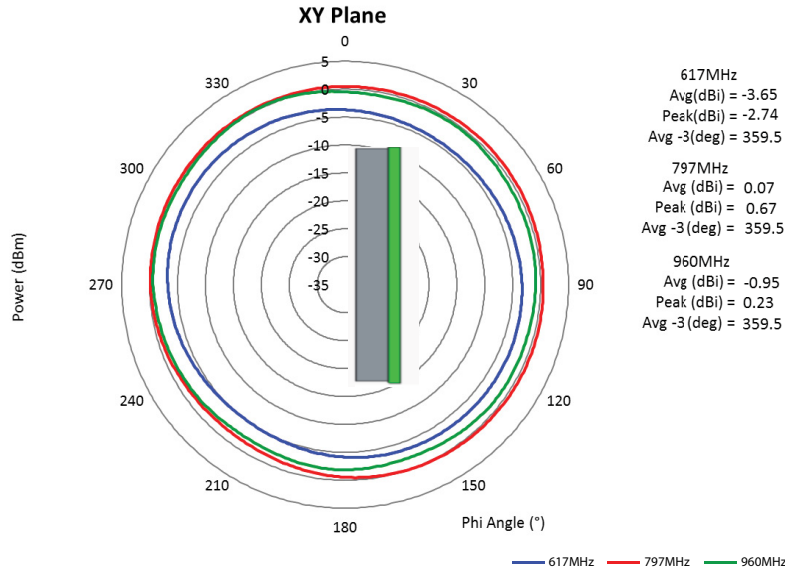

Embedded 5G/4G Wideband SMD Antenna

W3415 - 617MHz to 6000MHz

Charts

1400MHz - 2700MHz

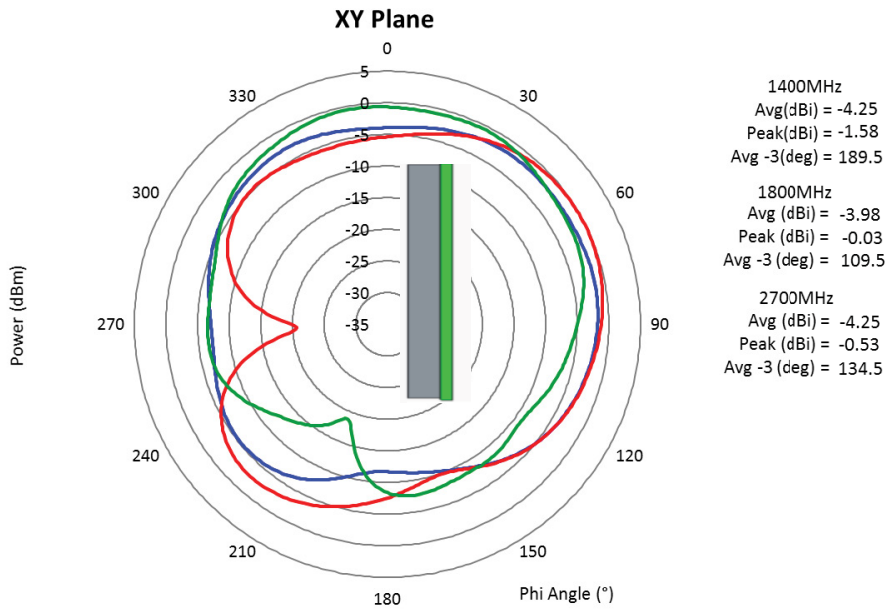

— 1400MHz — 1800MHz — 2700MHz

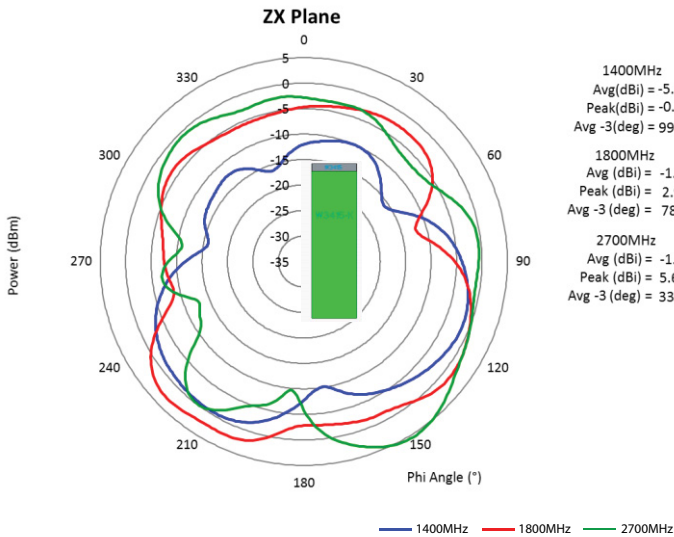

— 1400MHz — 1800MHz — 2700MHz

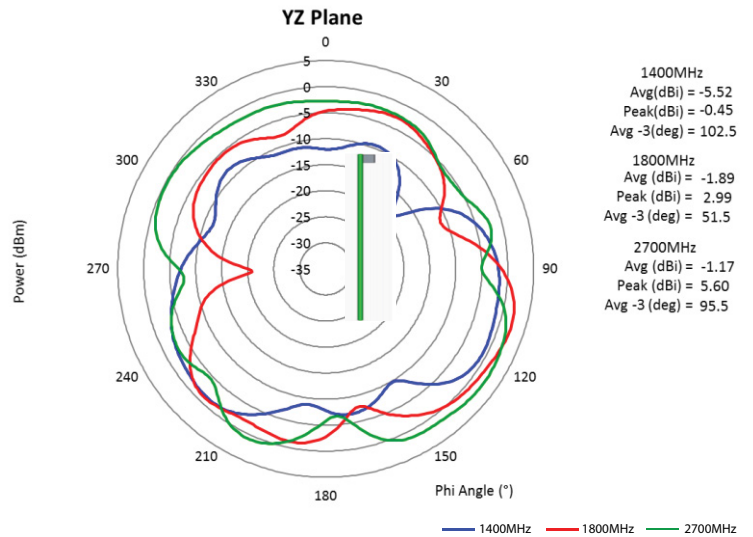

— 1400MHz — 1800MHz — 2700MHz

Embedded 5G/4G Wideband SMD Antenna

W3415 - 617MHz to 6000MHz

Charts

3400MHz - 3900MHz

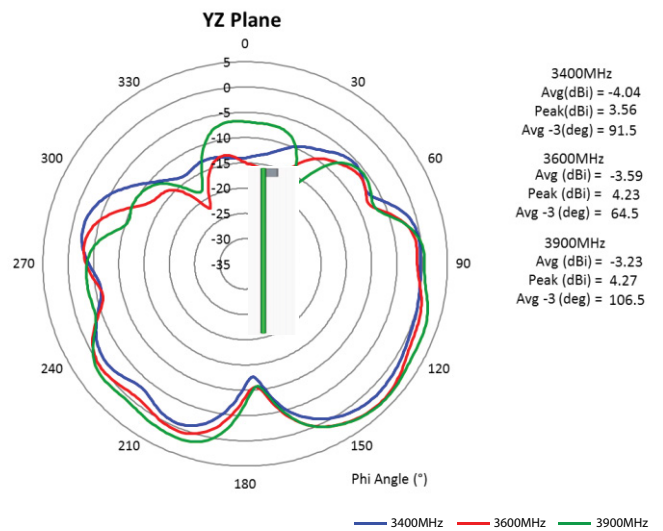
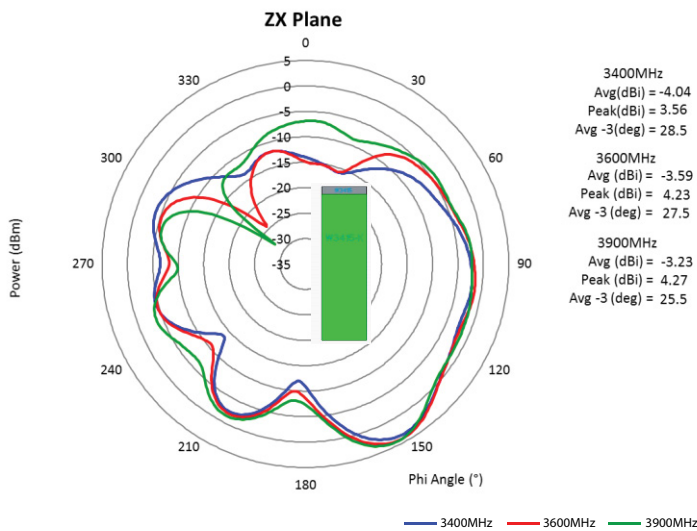
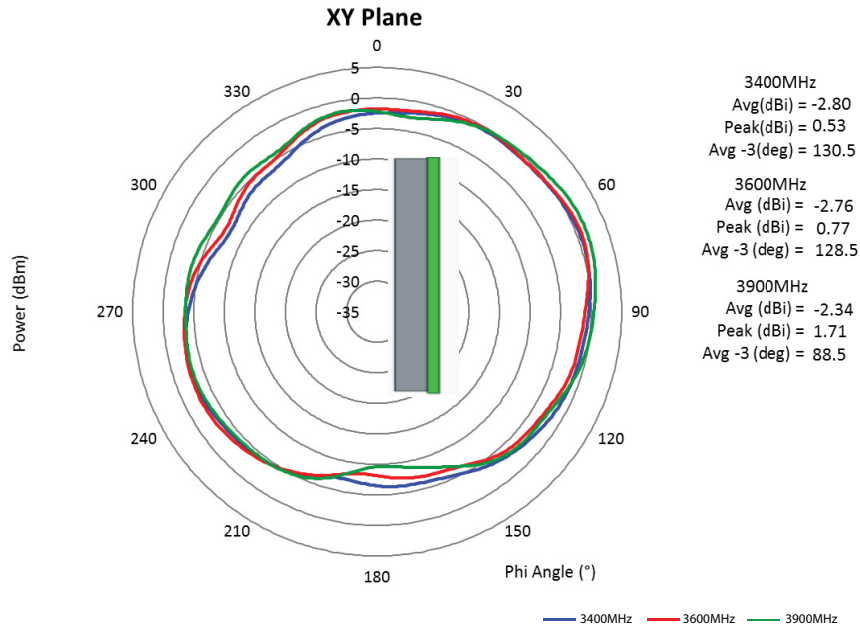

Embedded 5G/4G Wideband SMD Antenna

W3415 - 617MHz to 6000MHz

Charts

4900MHz - 5900MHz

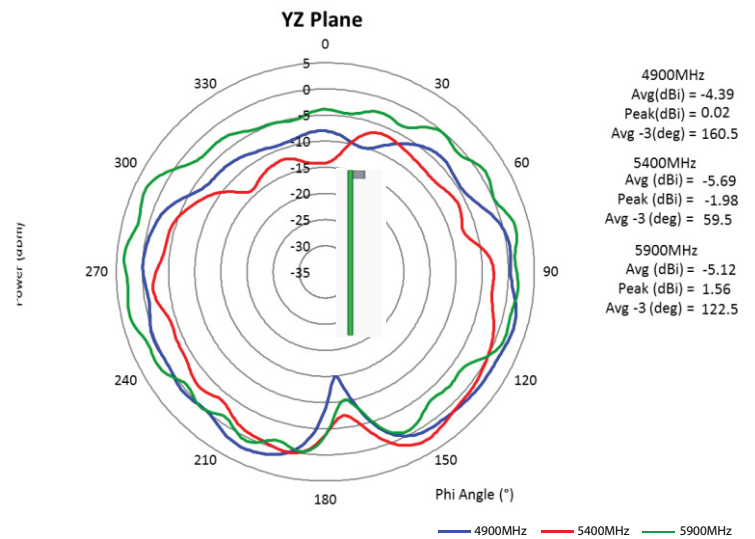
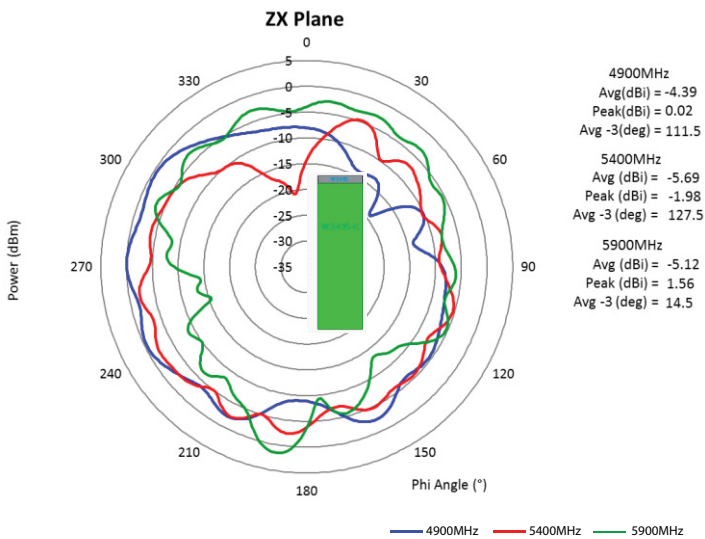
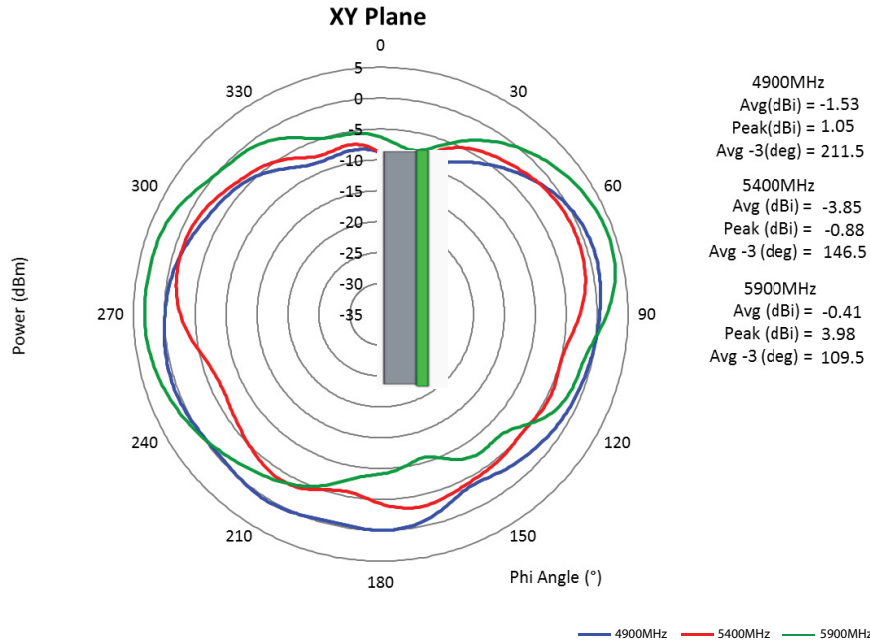

For More Information:

Americas - antennas.us@pulseelectronics.com | Europe - antennas.eu@pulseelectronics.com | Asia - antennas.as@pulseelectronics.com | Questions? +1-800-ANTENNA

Performance warranty of products offered on this data sheet is limited to the parameters specified. Data is subject to change without notice. Other brand and product names mentioned herein may be trademarks or registered trademarks of their respective owners. © Copyright, 2020. Pulse Electronics, Inc. All rights reserved.