

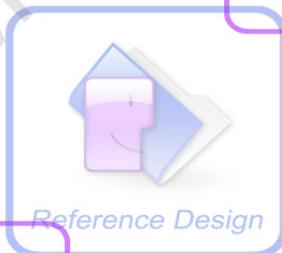

A company of SIM Tech

SIM868_Hardware_Design_V1.03

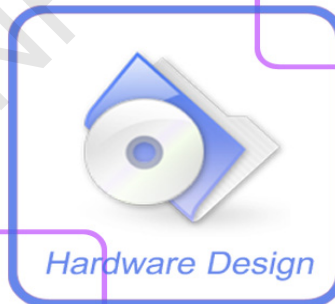

SIMCOM CONFIDENTIAL FILE

Document Title	SIM868 Hardware Design
Version	V1.03
Date	2017-02-18
Status	Release
Document Control ID	SIM868_Hardware_Design_V1.03

General Notes

SIMCom offers this information as a service to its customers, to support application and engineering efforts that use the products designed by SIMCom. The information provided is based upon requirements specifically provided to SIMCom by the customers. SIMCom has not undertaken any independent search for additional relevant information, including any information that may be in the customer's possession. Furthermore, system validation of this product designed by SIMCom within a larger electronic system remains the responsibility of the customer or the customer's system integrator. All specifications supplied herein are subject to change.

Copyright

This document contains proprietary technical information which is the property of SIMCom Limited, copying of this document and giving it to others and the using or communication of the contents thereof, are forbidden without express authority. Offenders are liable to the payment of damages. All rights reserved in the event of grant of a patent or the registration of a utility model or design. All specification supplied herein are subject to change without notice at any time.

Copyright © Shanghai SIMCom Wireless Solutions Ltd. 2017

Contents

1. Introduction.....	10
2. SIM868 Overview	10
2.1. SIM868 Key Features	11
2.2. Operating Modes.....	14
2.3. Functional Diagram.....	15
3. Package Information	16
3.1. Pin Out Diagram	16
3.2. Pin Description.....	17
3.3. Package Dimensions	19
4. Application Modes of SIM868.....	22
4.1. All-in-one Mode.....	22
4.2. Stand-alone Mode	23
5. Application Interface of GSM	24
5.1. Power Supply of GSM	24
5.2. Reference Circuit of GSM Power Supply.....	25
5.3. Power on/off GSM Part.....	26
5.3.1. Power on GSM.....	26
5.3.2. Power off GSM	27
5.4. Power Saving Mode of GSM.....	28
5.4.1. Minimum Functionality Mode of GSM Part.....	28
5.5. Serial Port of GSM.....	29
5.5.1. Function of Serial Port	30
5.5.2. Serial Interfaces.....	30
5.5.3. Debug Interface	32
5.5.4. Software Upgrade of GSM.....	33
5.6. UART1_RI Behaviors.....	33
5.7. Audio Interfaces	34
5.7.1. Speaker Interfaces Configuration.....	35
5.7.2. Microphone Interfaces Configuration	36
5.7.3. Audio Electronic Characteristic	36
5.7.4. TDD Noise of GSM	36
5.8. SIM Card Interface.....	37
5.8.1. SIM Card Application	37
5.8.2. SIM Card Design Guide.....	38
5.8.3. Design Considerations for SIM Card Holder	39
5.9. SD Interface	41
5.10. I2C Bus	41
5.11. ADC	41

5.12.	Network Status Indication.....	42
5.13.	Operating Status Indication.....	42
5.14.	RF Synchronization Signal	43
5.15.	Antenna Interface of GSM.....	43
6.	Application Interface of GNSS.....	45
6.1.	GNSS Overview.....	45
6.2.	Power Supply of GNSS.....	45
6.3.	Backup Power of GNSS.....	45
6.4.	Power on/off GNSS	46
6.5.	Serial Port of GNSS	47
6.6.	Software Upgrade of GNSS.....	48
6.7.	1PPS Output.....	48
6.8.	Antenna Interface.....	49
6.8.1.	Passive Antenna	49
6.8.2.	Active Antenna.....	50
6.9.	Operation Modes of GNSS	50
6.10.	A-GPS	52
6.10.1.	Easy Mode	52
6.10.2.	EPO.....	52
6.11.	Fast-Fix	52
6.12.	Multi-tone AIC	53
6.13.	SBAS.....	53
7.	PCB Layout	54
7.1.	Pin Assignment	54
7.2.	Principle of PCB Layout.....	55
7.2.1.	Antenna Interface.....	55
7.2.2.	Power Supply	55
7.2.3.	SIM Card Interface.....	55
7.2.4.	Audio Interface.....	55
8.	Electrical, Reliability and Radio Characteristics	56
8.1.	Absolute Maximum Ratings	56
8.2.	Recommended Operating Conditions	56
8.3.	Digital Interface Characteristics.....	56
8.4.	SIM Card Interface Characteristics.....	57
8.5.	SIM_VDD Characteristics	57
8.6.	VDD_EXT Characteristics.....	57
8.7.	Current Consumption (GSM_VBAT=4.0V)	57
8.8.	Electro-Static Discharge.....	58
8.9.	Radio Characteristics	59
8.9.1.	Module RF Output Power	59
8.9.2.	Module RF Receive Sensitivity.....	60
8.9.3.	Module Operating Frequencies	60

9. Manufacturing	61
9.1. Top and Bottom View of SIM868	61
9.2. Typical Solder Reflow Profile.....	61
9.3. The Moisture Sensitivity Level.....	62
9.4. Baking Requirements.....	62
10. Appendix	63
10.1. Related Documents	63
10.2. Terms and Abbreviations	64
10.3. Safety Caution.....	66

SIMCOM CONFIDENTIAL FILE

Table Index

TABLE 1: KEY FEATURES OF GSM PART.....	11
TABLE 2: CODING SCHEMES AND MAXIMUM NET DATA RATES OVER AIR INTERFACE	12
TABLE 3: KEY FEATURES OF GNSS PART	12
TABLE 4: OVERVIEW OF GSM OPERATING MODES	14
TABLE 5: OVERVIEW OF GNSS OPERATING MODES.....	15
TABLE 6: PIN DESCRIPTION	17
TABLE 7: RECOMMENDED ZENER DIODE	24
TABLE 8: THE CURRENT CONSUMPTION OF FUNCTION MODE.....	28
TABLE 9: SERIAL PORT PIN DEFINITION.....	29
TABLE 10: SERIAL PORT CHARACTERISTICS.....	30
TABLE 11: USB_VBUS OPERATION VOLTAGE	33
TABLE 12: UART_RI BEHAVIOURS.....	33
TABLE 13: AUDIO INTERFACE DEFINITION.....	34
TABLE 14: PERFORMANCE OF AUDIO AMPLIFIER.....	35
TABLE 15: MICROPHONE INPUT CHARACTERISTICS.....	36
TABLE 16: AUDIO OUTPUT CHARACTERISTICS	36
TABLE 17: SIM PIN DEFINITION.....	37
TABLE 18: PIN DESCRIPTION (MOLEX SIM CARD HOLDER)	39
TABLE 19: PIN DESCRIPTION (AMPHENOL SIM CARD HOLDER).....	40
TABLE 20: PIN DEFINITION OF THE I2C	41
TABLE 21: PIN DEFINITION OF THE ADC.....	41
TABLE 22: ADC SPECIFICATION	42
TABLE 23: PIN DEFINITION OF THE NETLIGHT	42
TABLE 24: STATUS OF THE NETLIGHT	42
TABLE 25: PIN DEFINITION OF THE STATUS.....	43
TABLE 26: DEFINITION OF THE RF_SYNC PIN.....	43
TABLE 27: RECOMMENDED TVS COMPONENT	44
TABLE 28: SERIAL PORT PIN DEFINITION	47
TABLE 29: SERIAL PORT CHARACTERISTICS.....	47
TABLE 30: RECOMMENDED BPF COMPONENT.....	50
TABLE 31: DEFAULT CONFIGURATION OF GNSS (FULL ON MODE).....	50
TABLE 32: ABSOLUTE MAXIMUM RATINGS.....	56
TABLE 33: RECOMMENDED OPERATING CONDITIONS	56
TABLE 34: DIGITAL INTERFACE CHARACTERISTICS	56
TABLE 35: SIM CARD INTERFACE CHARACTERISTICS	57
TABLE 36: SIM_VDD CHARACTERISTICS.....	57
TABLE 37: VDD_EXT CHARACTERISTICS	57
TABLE 38: CURRENT CONSUMPTION	57
TABLE 39: THE ESD CHARACTERISTICS (TEMPERATURE: 25°C, HUMIDITY: 45 %).....	58
TABLE 40: GSM850 AND EGSM900 CONDUCTED RF OUTPUT POWER.....	59
TABLE 41: DCS1800 AND PCS1900 CONDUCTED RF OUTPUT POWER.....	59
TABLE 42: CONDUCTED RF RECEIVE SENSITIVITY	60
TABLE 43: OPERATING FREQUENCIES.....	60
TABLE 44: MOISTURE SENSITIVITY LEVEL AND FLOOR LIFE	62
TABLE 45: BAKING REQUIREMENTS	62

TABLE 46: RELATED DOCUMENTS	63
TABLE 47: TERMS AND ABBREVIATIONS.....	64
TABLE 48: SAFETY CAUTION.....	66

SIMCOM CONFIDENTIAL FILE

Figure Index

FIGURE 1: SIM868 BLOCK DIAGRAM	15
FIGURE 2: PIN OUT DIAGRAM (TOP VIEW)	16
FIGURE 3: DIMENSIONS OF SIM868 (UNIT: MM)	19
FIGURE 4: RECOMMENDED PCB FOOTPRINT OUTLINE	20
FIGURE 5: RECOMMENDED SMT STENCIL FOOTPRINT OUTLINE	21
FIGURE 6: ALL-IN-ONE MODE DIAGRAM.....	22
FIGURE 7: STAND-ALONE MODE DIAGRAM	23
FIGURE 8: REFERENCE CIRCUIT OF THE GSM_VBAT INPUT	24
FIGURE 9: THE MINIMAL GSM_VBAT VOLTAGE REQUIREMENT AT GSM_VBAT DROP	24
FIGURE 10: REFERENCE CIRCUIT OF THE LDO POWER SUPPLY	25
FIGURE 11: REFERENCE CIRCUIT OF THE DC-DC POWER SUPPLY	25
FIGURE 12: THE MINIMAL VBAT VOLTAGE REQUIREMENT AT VBAT DROP	25
FIGURE 13: POWERED ON/OFF GSM USING TRANSISTOR	26
FIGURE 14: POWERED ON/OFF GSM USING BUTTON.....	26
FIGURE 15: TIMING OF POWER ON GSM.....	26
FIGURE 16: TIMING OF POWER OFF GSM.....	27
FIGURE 17: TIMING OF RESTART GSM.....	28
FIGURE 18: CONNECTION OF THE SERIAL INTERFACES.....	31
FIGURE 19: RESISTOR MATCHING CIRCUIT	31
FIGURE 20 : DIODE ISOLATION CIRCUIT.....	31
FIGURE 21: TX LEVEL MATCHING CIRCUIT	32
FIGURE 22: RX LEVEL MATCHING CIRCUIT.....	32
FIGURE 23: USB REFERENCE CIRCUIT	32
FIGURE 24: CONNECTION FOR SOFTWARE UPGRADING.....	33
FIGURE 25: UART1_RI BEHAVIOUR OF VOICE CALLING AS A RECEIVER.....	34
FIGURE 26: UART1_RI BEHAVIOUR OF URC OR RECEIVE SMS.....	34
FIGURE 27: UART1_RI BEHAVIOUR AS A CALLER.....	34
FIGURE 28: SPEAKER REFERENCE CIRCUIT	35
FIGURE 29: MICROPHONE REFERENCE CIRCUIT.....	36
FIGURE 30: REFERENCE CIRCUIT OF THE 8-PIN SIM CARD HOLDER.....	38
FIGURE 31: REFERENCE CIRCUIT OF THE 6-PIN SIM CARD HOLDER.....	38
FIGURE 32: MOLEX 91228 SIM CARD HOLDER.....	39
FIGURE 33: AMPHENOL C707 10M006 512 SIM CARD HOLDER.....	40
FIGURE 34: SD REFERENCE CIRCUIT.....	41
FIGURE 35: REFERENCE CIRCUIT OF NETLIGHT.....	42
FIGURE 36: RF_SYNC SIGNAL DURING TRANSMIT BURST	43
FIGURE 37: GSM ANTENNA MATCHING CIRCUIT.....	44
FIGURE 38: GSM ANTENNA MATCHING CIRCUIT WITHOUT RF CONNECTOR	44
FIGURE 39: REFERENCE CIRCUIT OF THE GPS_VBAT INPUT	45
FIGURE 40: RTC SUPPLY FROM RECHARGEABLE BATTERY	46
FIGURE 41: RTC SUPPLY FROM EXTERNAL POWER.....	46
FIGURE 42: POWER ON/OFF GNSS.....	47
FIGURE 43: TIMING OF POWER ON GNSS.....	47
FIGURE 44: TIMING OF POWER OFF GNSS	47
FIGURE 45: CONNECTION FOR SOFTWARE UPGRADING AND DEBUGGING FOR GNSS	48
FIGURE 46: CONNECTION FOR SOFTWARE UPGRADING IN ALL-IN-ONE MODE.....	48

FIGURE 47: 1PPS APPLICATION CIRCUIT	49
FIGURE 48: GNSS PASSIVE ANTENNA MATCHING CIRCUIT	49
FIGURE 49: GNSS ACTIVE ANTENNA MATCHING CIRCUIT.....	50
FIGURE 50: PIN ASSIGNMENT	54
FIGURE 51: TOP AND BOTTOM VIEW OF SIM868	61
FIGURE 52: TYPICAL SOLDER REFLOW PROFILE OF LEAD-FREE PROCESS	61

SIMCOM CONFIDENTIAL FILE

Version History

Date	Version	Description of change	Author
2016-06-20	1.00	Origin	Yanwu.Wang; Xiaoxu.Chen
2016-08-01	1.01	<ol style="list-style-type: none"> 1. Update figure 1 2. Add voltage range of GPS_VBAT 3. Add voltage range of VRTC 4. Add voltage range of GNSS_EN 5. Add Recommended SMT stencil footprint 6. Delete Over-Temperature or Under-Temperature Power off 7. Change PWRKEY pin from at least 1 second to 1.5 second for power off the module 8. Add GNSS software update part 9. Delete Multiplexing function 10. Add BPF component in GNSS part 	Yanwu.Wang; Xiaoxu.Chen
2016-11-24	1.02	<ol style="list-style-type: none"> 1. Add Application Mode 2. Add Power Supply of GNSS 3. Add Power Saving Mode of GNSS 4. Add operation mode of GNSS 5. Modify Backup Power of GNSS 6. Add software upgrading in Simultaneous mode 7. Add Application of GNSS 8. Add A-GPS、Fast-Fix、 Easy-Mode、 SBAS、 GLP 	Yanwu.Wang; Xiaoxu.Chen
2017-02-18	1.03	<ol style="list-style-type: none"> 1. Update Tab 3, Tab 6(GPS_VBAT 2.9V~4.4V) 2. Update backup current to 8uA, stop current to 590uA 3. Update periodic mode 4. Update AlwaysLocate™ mode 5. Delete the blank of document 	Ming.zhu

1. Introduction

This document describes SIM868 hardware interface in great detail. The document can help customers to understand SIM868 interface specifications, electrical and mechanical details. With the help of this document and other SIM868 application notes, customer guide, customers can use SIM868 to design various applications quickly.

2. SIM868 Overview

Designed for global market, SIM868 is integrated with a high performance GSM/GPRS part and a GNSS part. The GSM part is a quad-band GSM/GPRS that works on frequencies GSM 850 MHz, EGSM 900MHz, DCS 1800MHz and PCS 1900MHz. GSM features GPRS multi-slot class 12/class 10 (optional) and supports the GPRS coding schemes CS-1, CS-2, CS-3 and CS-4.

The GNSS part solution offers best-in-class acquisition and tracking sensitivity, Time-To-First-Fix (TTFF) and accuracy. With built-in LNA, GNSS doesn't need external LNA. GNSS can track as low as -167dBm signal even without network assistance. The GNSS has excellent low power consumption characteristic (acquisition 24mA, tracking 22mA). GNSS supports various location and navigation applications, including autonomous GPS, GLONASS, BEIDOU, QZSS, SBAS (WAAS, EGNOS, GAGAN, and MSAS) and A-GPS.

With a tiny configuration of 17.6*15.7*2.3mm, SIM868 can meet almost all the space requirements in customers' applications, such as smart phone, PDA and other mobile devices.

SIM868 has a SMT+LGA package with 77 pads, and provides all hardware interfaces between the module and customers' boards.

- One three-line serial port, one full modem serial port and one GNSS serial port.
- USB interface
- Audio channels which include a microphone input and two speakers output
- Programmable general purpose input and output
- Two SIM card interfaces
- SD card interface
- I2C interface
- ADC interface
- Support GNSS function
- 33tracking/99 acquisition-channel GNSS receiver
- 12 multi-tone active interference cancellers and jamming elimination
- Max fixed update rate up to 10 HZ (1Hz default)
- Accuracy 2.5m CEP

SIM868 is designed with power saving technique so that the current consumption is as low as 0.65 mA in sleep mode (with GNSS part power off).

SIM868 integrates TCP/IP protocol and extended TCP/IP AT commands which are very useful for data transfer applications. For details about TCP/IP applications, please refer to document [3].

2.1. SIM868 Key Features

Table 1: Key Features of GSM Part

Feature	Implementation
Power supply	3.4V ~4.4V
Power saving	Typical power consumption in sleep mode is 0.65mA (AT+CFUN=0)
Frequency bands	<ul style="list-style-type: none"> ● Quad-band: GSM 850, EGSM 900, DCS 1800, PCS 1900. SIM868 can search the 4 frequency bands automatically. The frequency bands can also be set by AT command “AT+CBAND”. For details, please refer to document [1]. ● Compliant to GSM Phase 2/2+
Transmitting power	<ul style="list-style-type: none"> ● Class 4 (2W) at GSM 850 and EGSM 900 ● Class 1(1W) at DCS 1800 and PCS 1900
GPRS connectivity	<ul style="list-style-type: none"> ● GPRS multi-slot class 12(default) ● GPRS multi-slot class 1~12 (option)
Temperature range	<ul style="list-style-type: none"> ● Normal operation:-40°C ~ +85°C ● Storage temperature -45°C ~ +90°C
Data GPRS	<ul style="list-style-type: none"> ● GPRS data downlink transfer: max. 85.6 kbps ● GPRS data uplink transfer: max. 85.6 kbps ● Coding scheme: CS-1, CS-2, CS-3 and CS-4 ● PAP protocols for PPP connect ● Integrate the TCP/IP protocol ● Support Packet Broadcast Control Channel (PBCCH)
USSD	<ul style="list-style-type: none"> ● Unstructured Supplementary Services Data (USSD) support
SMS	<ul style="list-style-type: none"> ● MT, MO, CB, Text and PDU mode. ● SMS storage: SIM card
SIM interface	Support SIM card: 1.8V, 3V
FLASH	32Mbit
RAM	32Mbit
Audio features	Speech codec modes: <ul style="list-style-type: none"> ● Half Rate (ETS 06.20) ● Full Rate (ETS 06.10) ● Enhanced Full Rate (ETS 06.50 / 06.60 / 06.80) ● Adaptive multi rate (AMR) ● Echo Cancellation ● Noise Suppression
Serial port and USB port	Serial port: <ul style="list-style-type: none"> ● Default one full modem serial port ● Can be used for AT commands or data stream ● Support RTS/CTS hardware handshake and software ON/OFF flow control ● Multiplex ability according to GSM 07.10 Multiplexer Protocol ● Autobauding supports baud rate from 1200 bps to 115200bps ● upgrading firmware

	USB port: <ul style="list-style-type: none"> ● Can be used for debugging and upgrading firmware
Phonebook management	Support phonebook types: SM, FD, LD, RC, ON, MC.
SIM application toolkit	GSM 11.14 Release 99
Physical characteristics	<ul style="list-style-type: none"> ● Size:17.6*15.7*2.3mm ● Weight:1.5g
Firmware upgrade	Full modem serial port or USB interface

Table 2: Coding schemes and maximum net data rates over air interface

Coding scheme	1 timeslot	2 timeslot	4 timeslot
CS-1	9.05kbps	18.1kbps	36.2kbps
CS-2	13.4kbps	26.8kbps	53.6kbps
CS-3	15.6kbps	31.2kbps	62.4kbps
CS-4	21.4kbps	42.8kbps	85.6kbps

Table 3: Key Features of GNSS Part

Parameter	Description	Performance			
		Min	Typ	Max	Unit
Power supply	Power supply	2.9	3	4.4	V
Horizontal Position Accuracy ⁽¹⁾	Autonomous		<2.5		m
Velocity Accuracy ⁽²⁾	Without Aid		0.1		m/s
Acceleration Accuracy	Without Aid		0.1		m/s ²
Accuracy of 1PPS			10		nS
Backup batter voltage	VRTC	2.3		4.3	V
Dynamic Performance	Maximum Altitude			18000	m
	Maximum Velocity			515	m/s
	Maximum Acceleration			4	G
TTFF with GPS only ⁽³⁾	Hot start		<1		s
	Warm start		21.4		s
	Cold start		22.3		s
TTFF with GLONASS only ⁽³⁾	Hot start		<1		s
	Warm start		21.2		s
	Cold start		21.68		s
TTFF with GPS and GLONASS ⁽³⁾	Hot start		<1		s
	Warm start		21.54		s
	Cold start		21.67		s
A-GPS TTFF(EPO in flash mode)	Hot start		<1		s
	Warm start		/		s
	Cold start		/		s
A-GPS TTFF(Easy)	Hot start		<1		s

mode)	Warm start		1.4		s
	Cold start		13.6		s
Sensitivity with GPS only mode	Autonomous acquisition(cold start)		-149		dBm
	Re-acquisition		-161		dBm
	Tracking		-167		dBm
Sensitivity with GLONASS only mode	Autonomous acquisition(cold start)		-147		dBm
	Re-acquisition		-155		dBm
	Tracking		-160		dBm
Sensitivity with GPS and GLONASS	Autonomous acquisition(cold start)		-149		dBm
	Re-acquisition		-161		dBm
	Tracking		-167		dBm
Receiver	Channels		33/99		
	Update rate			10	Hz
	Tracking L1, CA Code				
	Protocol support NMEA				
Power consumption With GPS only mode ⁽⁴⁾	Acquisition		24.5		mA
	Continuous tracking		22.2		mA
	GLP current		12		mA
	Sleep current		6.5		mA
	Stop current		490		uA
	Backup current		8		uA
Power consumption With BD only mode ⁽⁴⁾	Acquisition		31		mA
	Continuous tracking		31.2		mA
	GLP current		12		mA
	Sleep current		6.5		mA
	Stop current		490		uA
	Backup current		8		uA
Power consumption With GLONASS only mode ⁽⁴⁾	Acquisition		22.4		mA
	Continuous tracking		27.3		mA
	GLP current		12		mA
	Sleep current		6.5		mA
	Stop current		490		uA
	Backup current		8		uA
Power consumption With GPS and GLONASS ⁽⁴⁾	Acquisition		31		mA
	Continuous tracking		26		mA
	GLP current		12		mA
	Sleep current		6.5		mA
	Stop current		590		uA

	Backup current		8		uA
Power consumption With GPS and BD ⁽⁴⁾	Acquisition		31.2		mA
	Continuous tracking		25.8		mA
	GLP current		12		mA
	Sleep current		6.5		mA
	Stop current		490		uA
	Backup current		8		uA

- (1) 50% 24hr static, -130dBm
- (2) 50% at 30m/s
- (3) GPS signal level: -130dBm
- (4) Single Power supply 3V@-130dBm

2.2. Operating Modes

Table 4 summarizes the various operating modes of GSM:

Table 4: Overview of GSM operating modes

Mode	Function
Normal operation	GSM/GPRS SLEEP Module will automatically go into sleep mode if the conditions of sleep mode are enabling and there aren't on air and hardware interrupt (such as GPIO interrupt or data on serial port). In this case, the current consumption of module will reduce to the minimal level. In sleep mode, the module can still receive paging message and SMS.
	GSM IDLE Software is active. Module is registered to the GSM network and ready to communicate.
	GSM TALK Connection between two subscribers is in progress. In this case, the power consumption depends on network settings such as DTX off/on, FR/EFR/HR, hopping sequences and antenna.
	GPRS STANDBY Module is ready for GPRS data transfer, but no data is currently sent or received. In this case, power consumption depends on network settings and GPRS configuration.
	GPRS DATA There is GPRS data transfer (PPP or TCP or UDP) in progress. In this case, power consumption is related with network settings (e.g. power control level); uplink/downlink data rates and GPRS configuration (e.g. used multi-slot settings).
Power off	Normal power off by sending AT command "AT+CPOWD=1" or using the PWRKEY. The power management unit shuts down the power supply for the baseband part of the module. Software is not active. The serial port is not accessible. Power supply (connected to 3V) remains applied.
Minimum functionality mode	AT command "AT+CFUN" can be used to set the module to a minimum functionality mode without removing the power supply. In this mode, the RF part of the module will not work or the SIM card will not be accessible, or both RF part and SIM card will be closed, and the serial port is still accessible. The power consumption in this mode is lower than normal mode.

Table 5: Overview of GNSS operating modes

Mode	GPS_VBAT	GNSS_EN	VRTC	Main clock	RTC clock
Full on	on	H	on	on	on
Stop	on	H	on	off	on
Backup	X	L	on	off	on

Note: X means no matter GPS_VBAT is existed or not.

2.3. Functional Diagram

Figure 1 shows the block diagram of SIM868:

- GSM baseband
- PMU
- The GSM Radio Frequency part
- Antenna interface
- GNSS interface
- Other interface

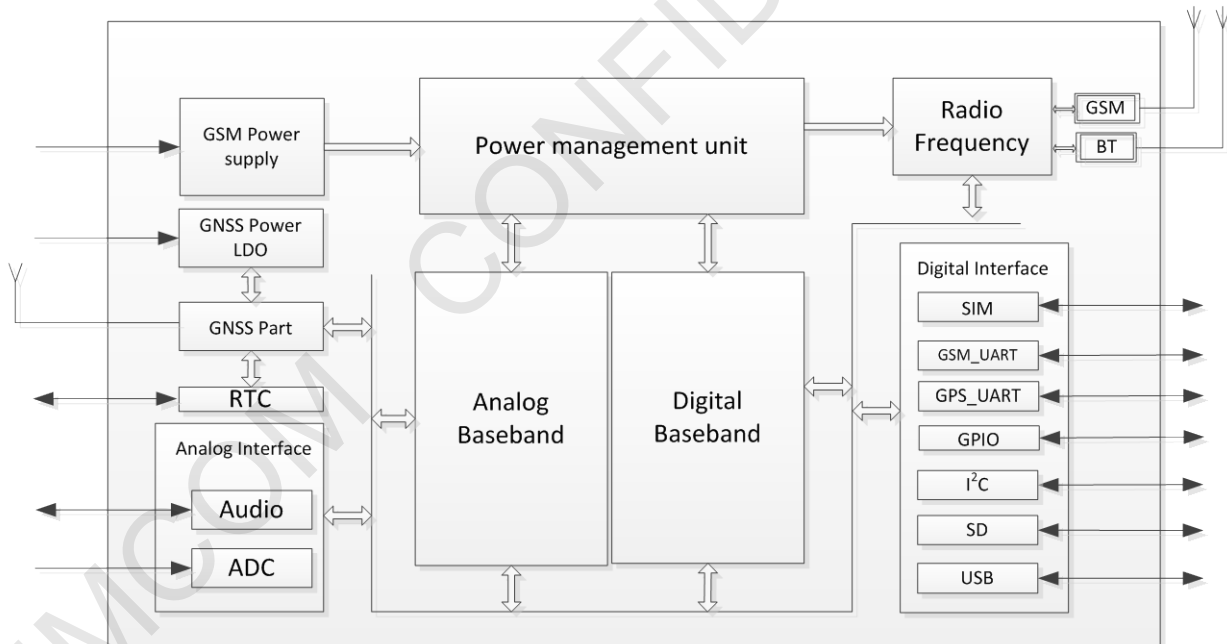
Figure 1: SIM868 block diagram

3. Package Information

3.1. Pin Out Diagram

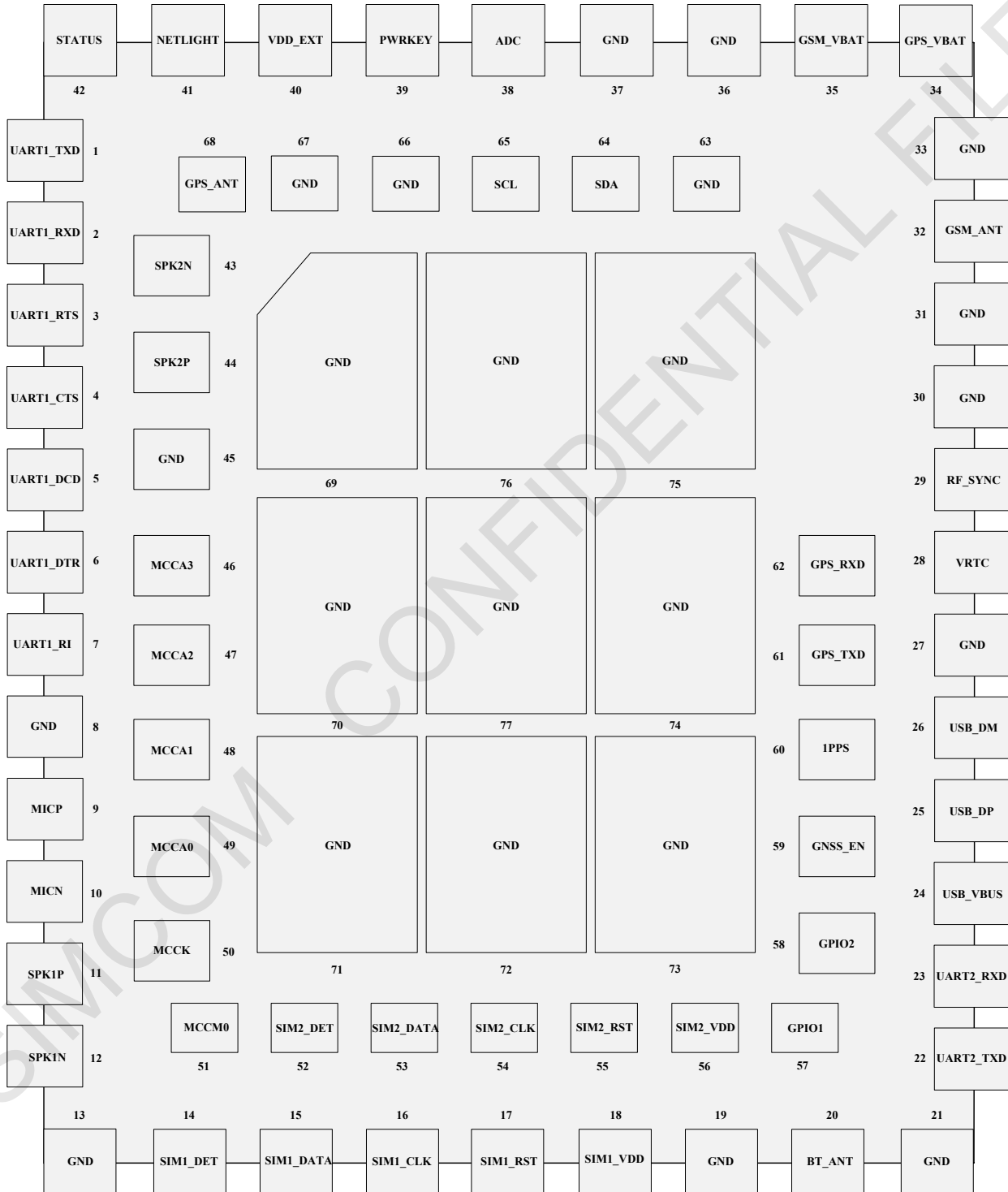

Figure 2: Pin out Diagram (Top view)

3.2. Pin Description

Table 6: Pin description

Pin name	Pin number	I/O	Description	Comment
Power supply				
GPS_VBAT	34	I	Power supply for GNSS	2.9V ~4.4V
GSM_VBAT	35	I	Power supply for GSM	3.4V ~4.4V
VDD_EXT	40	O	2.8V power output	If it is unused, keep open.
GND	8,13,19,21,27,30, 31,33,36,37,45,63, 66,67,69,70,71,72, 73,74,75,76,77		Ground	36、 37 pins recommend for GSM_VBAT.
Power on/off				
PWRKEY	39	I	PWRKEY should be pulled low and then released to power on/off the module.	Internally pulled up to 3V
Audio interface				
MICP	9	I	Differential audio input	If these pins are unused, keep open.
MICN	10			
SPK1P	11	O	Differential audio output	
SPK1N	12			
SPK2P	44			
SPK2N	43			
GNSS interface				
GPS_RXD	62	I	Receive data	If these pins are unused, keep open.
GPS_TXD	61	O	Transmit data	
1PPS	60	O	Time Mark outputs timing pulse	
GNSS_EN	59	I	GNSS power enable	
VRTC	28	I/O	Power supply for GNSS RTC	It is recommended to connect with a battery.
SD interface				
MCCA3	46	I/O	SD serial data I/O	If these pins are unused, keep open.
MCCA2	47	I/O		
MCCA1	48	I/O		
MCCA0	49	I/O		
MCKK	50	I/O	SD serial clock	
MCCM0	51	I/O	SD command output	
GPIO				
NETLIGHT	41	O	Network status	If these pins are unused, keep open.
STATUS	42	O	Power on status	
GPIO1	57	I/O	Programmable general purpose	
GPIO2	58	I/O	input and output.	

Serial port				
UART1_DTR	6	I	Data terminal ready	If these pins are unused, keep open.
UART1_RI	7	O	Ring indicator	
UART1_DCD	5	O	Data carrier detect	
UART1_CTS	4	O	Clear to send	
UART1_RTS	3	I	Request to send	
UART1_TXD	1	O	Transmit data	
UART1_RXD	2	I	Receive data	
UART2_TXD	22	O	Transmit data	
UART2_RXD	23	I	Receive data	
Debug interface				
USB_VBUS	24	I	Debug and download	If these pins are unused, keep open.
USB_DP	25	I/O		
USB_DM	26	I/O		
ADC				
ADC	38	I	10bit general analog to digital converter	If it is unused, keep open.
I2C				
SDA	64	I/O	I2C serial bus data	Internal pulled up to 2.8V via 4.7KΩ
SCL	65	O	I2C serial bus clock	
SIM card interface				
SIM1_VDD	18	O	Voltage supply for SIM card. Support 1.8V or 3V SIM card.	All signals of SIM interface should be protected against ESD.
SIM1_DATA	15	I/O	SIM data input/output	
SIM1_CLK	16	O	SIM clock	
SIM1_RST	17	O	SIM reset	If it is unused, keep open.
SIM1_DET	14	I	SIM card detection	
SIM2_VDD	56	O	Voltage supply for SIM card. Support 1.8V or 3V SIM card	All signals of SIM interface should be protected against ESD.
SIM2_DATA	53	I/O	SIM data input/output	
SIM2_CLK	54	O	SIM clock	
SIM2_RST	55	O	SIM reset	If it is unused, keep open.
SIM2_DET	52	I	SIM card detection	
Antenna interface				
GSM_ANT	32	I/O	Connect GSM antenna	If these pins are unused, keep open.
BT_ANT	20	I/O	Connect Bluetooth antenna	
GPS_ANT	68	I	Connect GNSS antenna	
Synchronizing signal of RF				
RF_SYNC	29	O	Synchronizing signal of RF	

3.3. Package Dimensions

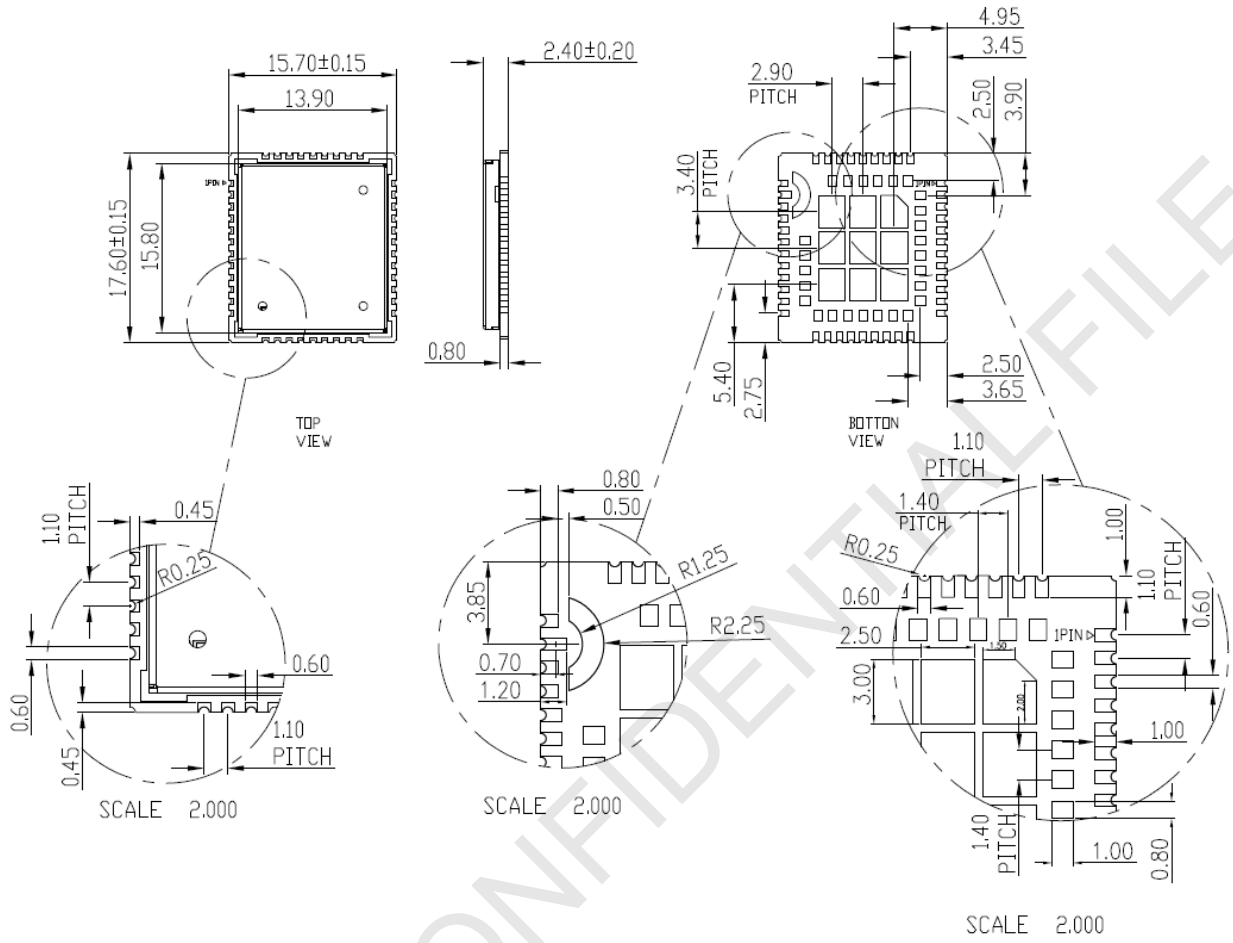

Figure 3: Dimensions of SIM868 (Unit: mm)

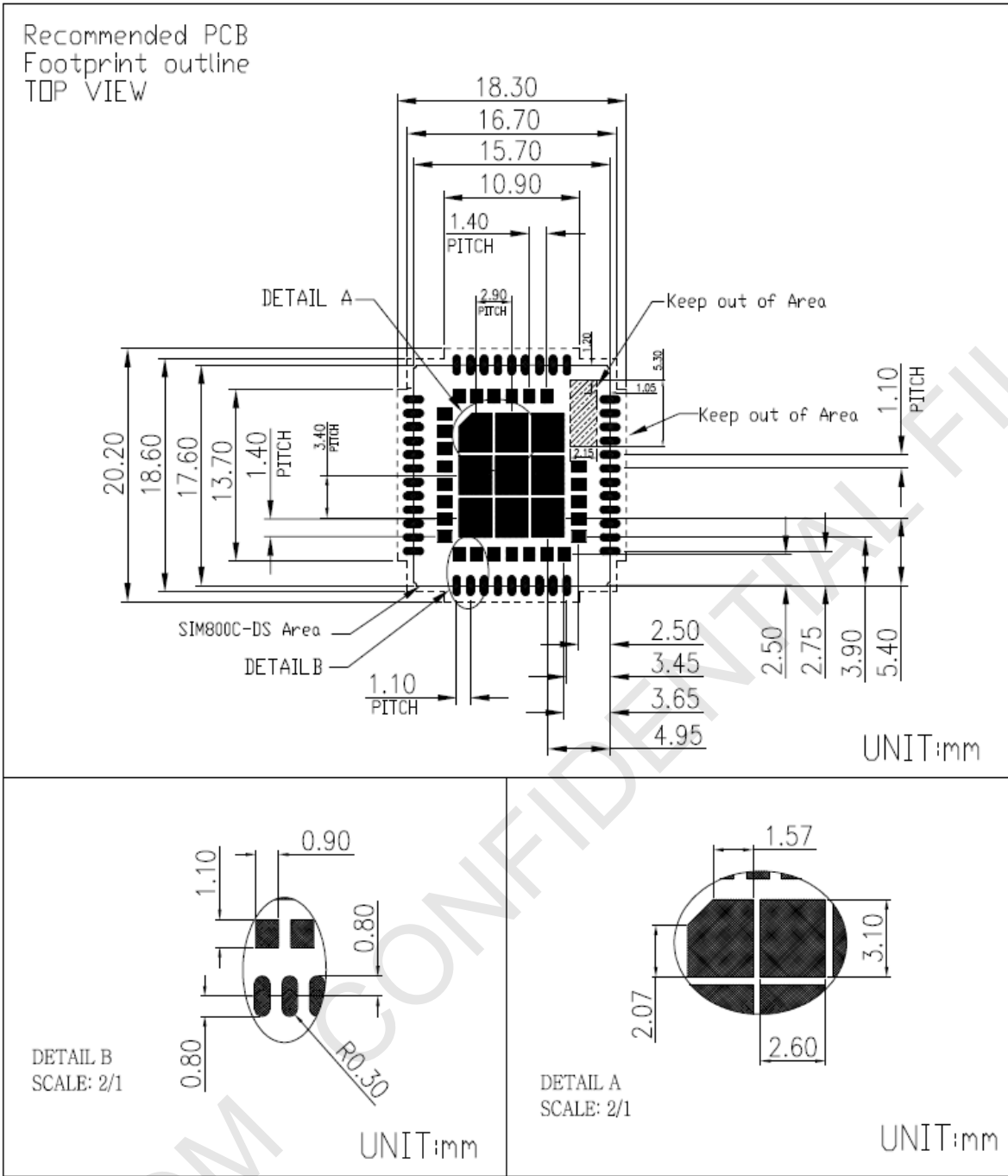

Figure 4: Recommended PCB footprint outline

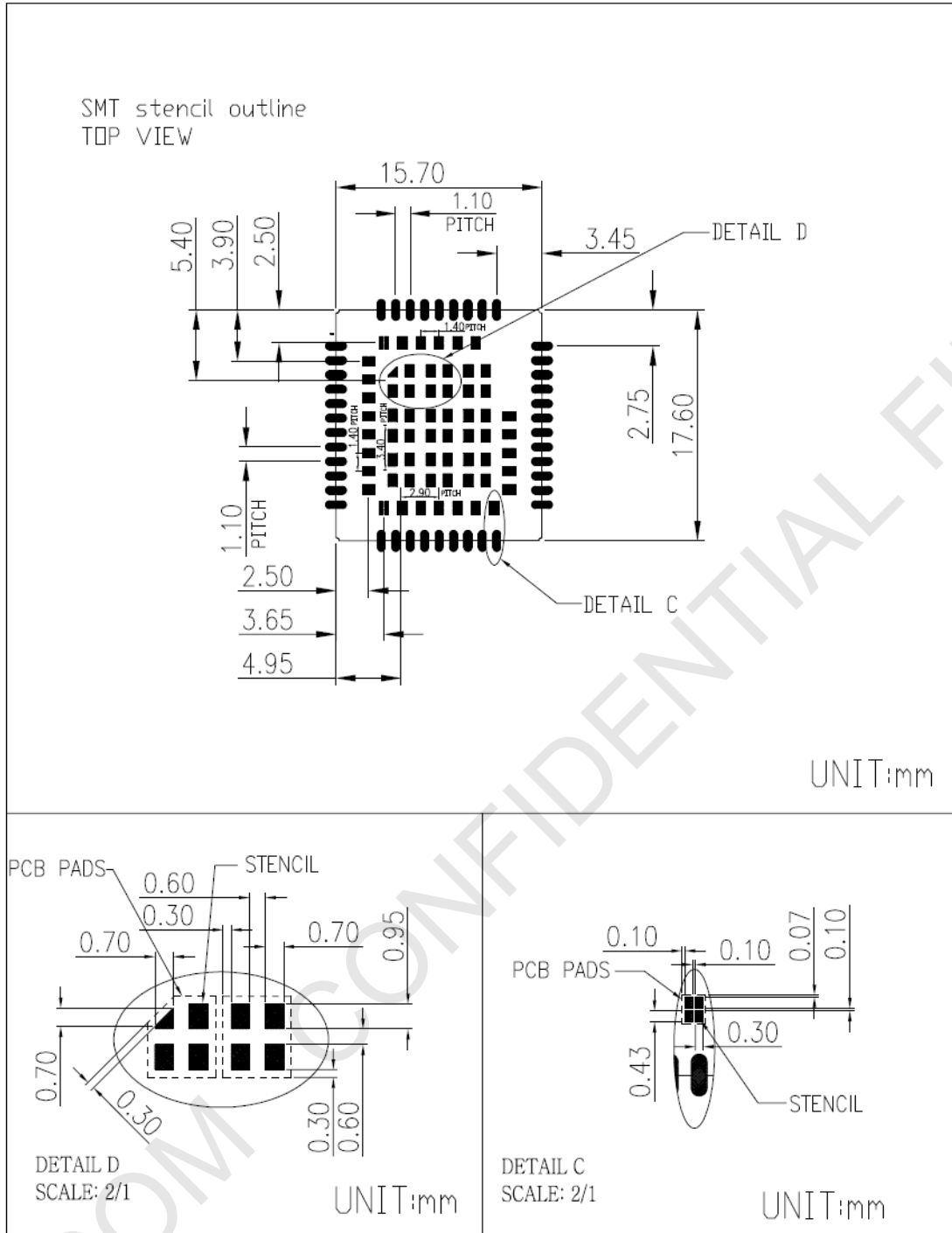

Figure 5: Recommended SMT stencil footprint outline

4. Application Modes of SIM868

4.1. All-in-one Mode

In all-in-one mode, UART2 of GSM is connected with GNSS_UART. It's convenient for communication between GSM and GNSS, such as control GNSS, firmware upgrade and download EPO data.

As the Figure 6, a 10K resistor should be added between GPIO1 and GNSS_EN pin.

In this mode, GNSS part can be enabled through AT command “AT+CGNSPWR=1” and disabled through AT command “AT+CGNSPWR=0”. GSM and GNSS’s firmware could be upgraded through UART1 port or USB with high-speed.

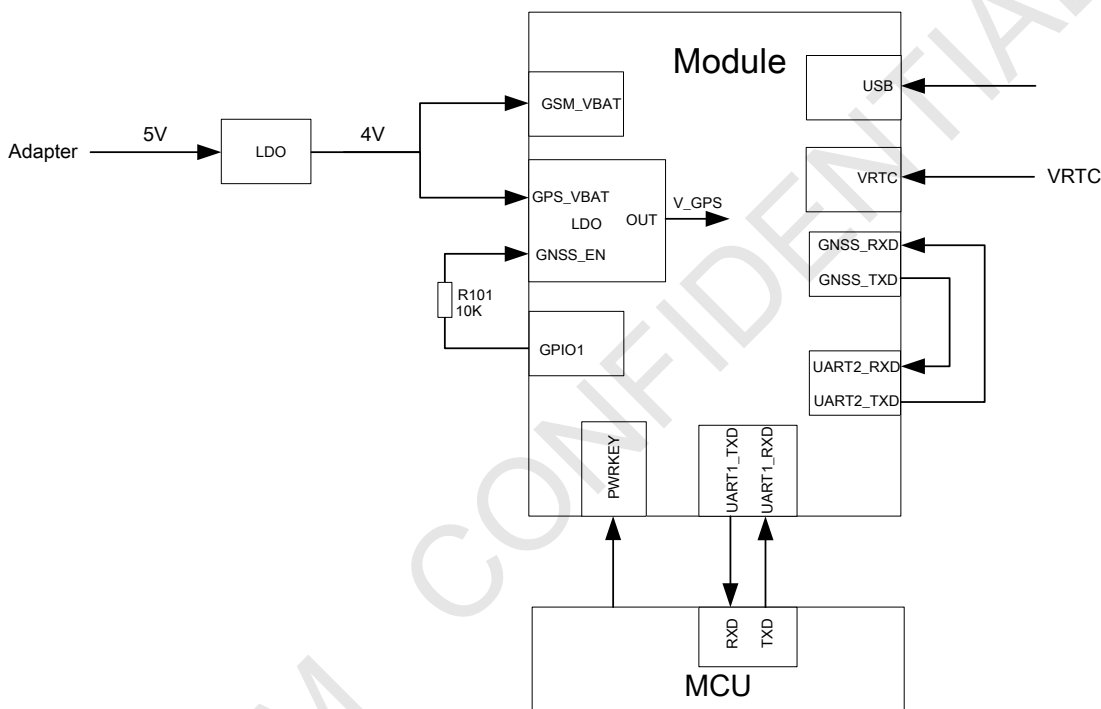

Figure 6: All-in-one Mode Diagram

4.2. Stand-alone Mode

In stand-alone mode, GSM and GNSS part can work independently. It's convenient for customer to control them separately. Figure 7 is the block diagram of this mode.

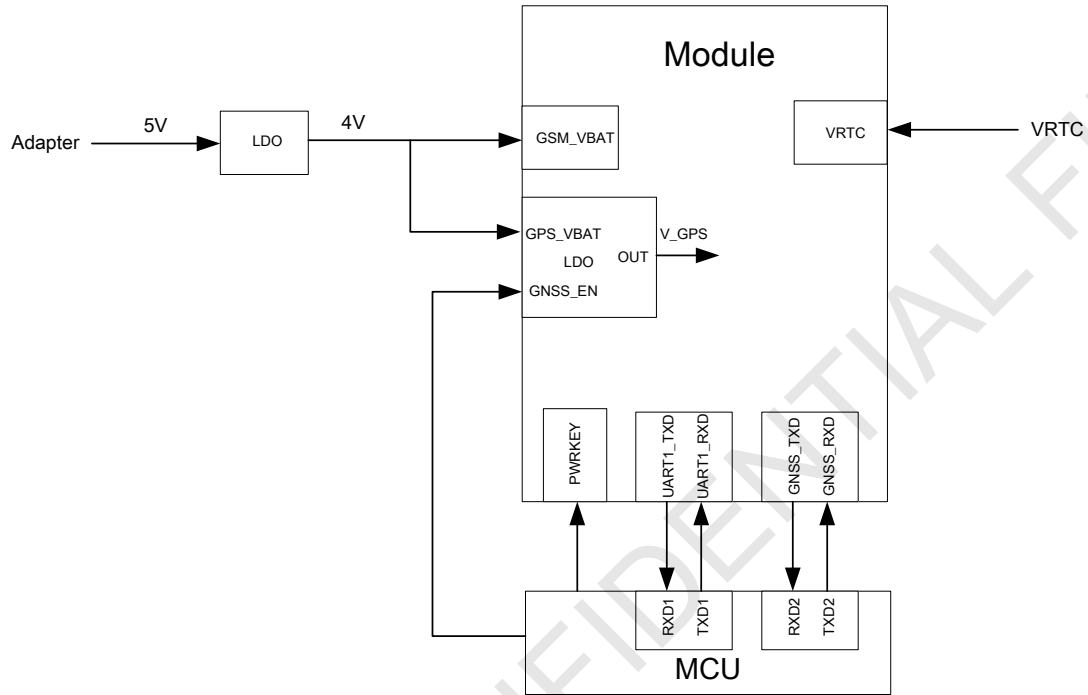

Figure 7: Stand-alone Mode Diagram

5. Application Interface of GSM

5.1. Power Supply of GSM

The recommended typical power supply voltage of GSM is 4.0V, and range from 3.4V to 4.4V. The maximum current consumption of GSM can reach 2A maximum during a transmitting burst period, which will cause a big voltage drop on the GSM_VBAT. So, to decrease the voltage drop, it is necessary to add an additional circuit at the GSM_VBAT pin, which is illustrated in Figure 8.

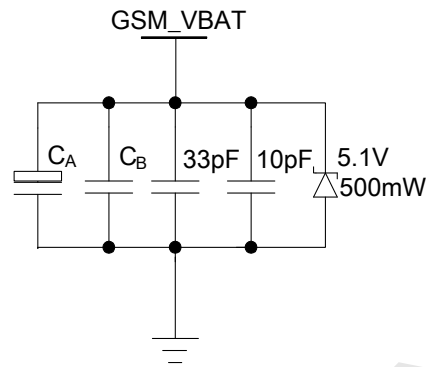

Figure 8: Reference circuit of the GSM_VBAT input

For the GSM_VBAT input, a 100uF tantalum capacitor C_A (low ESR) and a 1uF~10uF ceramics capacitor C_B are strongly recommended. Add the 33pF and 10pF capacitors can effectively eliminate the high frequency interference. A 5.1V/500mW zener diode is strongly recommended, which can prevent chip from damaging by the voltage surge. These capacitors and zener diode should be placed as close as possible to GSM_VBAT pin.

Table 7: Recommended zener diode

	Vendor	Part number	Power(watts)	Packages
1	On semi	MMSZ5231BT1G	500mW	SOD123
2	Prisemi	PZ3D4V2H	500mW	SOD323
3	Vishay	MMSZ4689-V	500mW	SOD123
4	Crownpo	CDZ55C5V1SM	500mW	0805

When designing the power supply circuit in customers' application, pay special attention to power loss. Ensure that the input GSM_VBAT voltage never drops below 3.0V even when current consumption rises to 2A in the transmit burst. If the GSM_VBAT voltage drops below 3.0V, the GSM may be shut off automatically. The PCB traces from the GSM_VBAT pin to the power supply must be wide enough (at least 60mil) to decrease voltage drops in the transmit burst. The power IC and the bypass capacitor should be placed to the GSM_VBAT as close as possible.

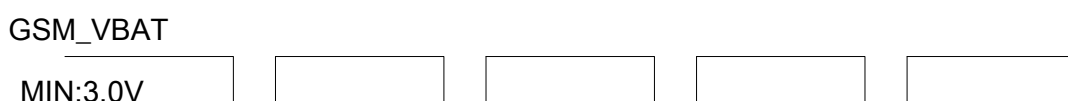

Figure 9: The minimal GSM_VBAT voltage requirement at GSM_VBAT drop

5.2. Reference Circuit of GSM Power Supply

Figure 10 is the reference design of +5V input power supply. The output power supply is 4.1V, thus a linear regulator can be used.

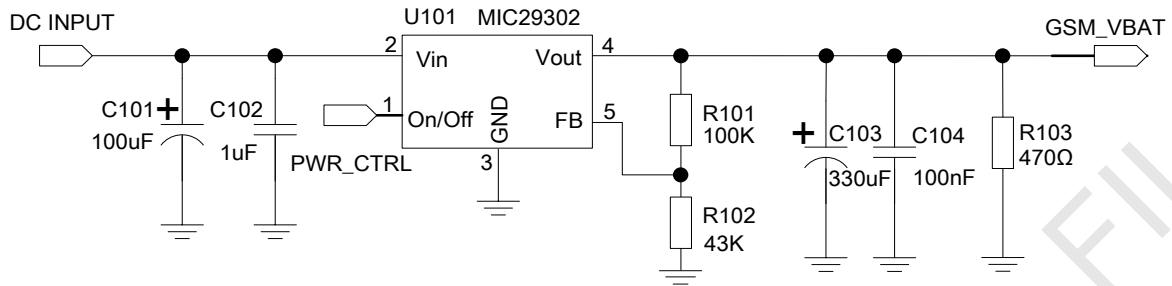

Figure 10: Reference circuit of the LDO power supply

If there is a high drop-out between the input and the desired output (GSM_VBAT), a DC-DC power supply will be preferable because of its better efficiency especially with the 2A peak current in burst mode of the GSM. Figure 11 is the reference circuit.

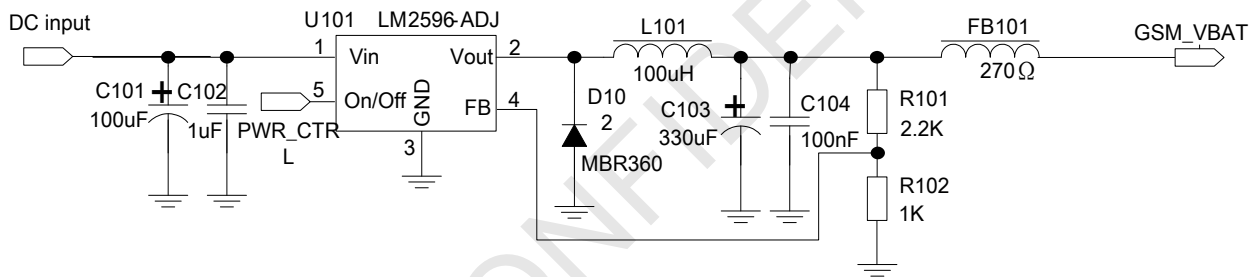

Figure 11: Reference circuit of the DC-DC power supply

When battery is used, the total impedance between battery and GSM_VBAT pins should be less than 150mΩ. Figure 12 shows the GSM_VBAT voltage drop at the maximum power transmit phase, and the test condition is as following:

- GSM_VBAT=4.0V,
- A GSM_VBAT bypass capacitor $C_A=100\mu\text{F}$ tantalum capacitor (ESR=0.7Ω),
- Another GSM_VBAT bypass capacitor $C_B=1\mu\text{F}\sim 10\mu\text{F}$.

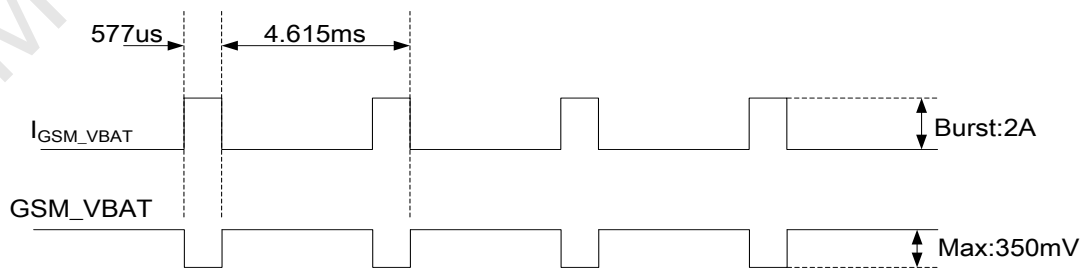

Figure 12: The minimal VBAT voltage requirement at VBAT drop

5.3. Power on/off GSM Part

5.3.1. Power on GSM

Customer can power on GSM by pulling down the PWRKEY pin for at least 1 second and then release. This pin is already pulled up to 3V in the module internal, so external pull up is not necessary. Reference circuits are shown as below.

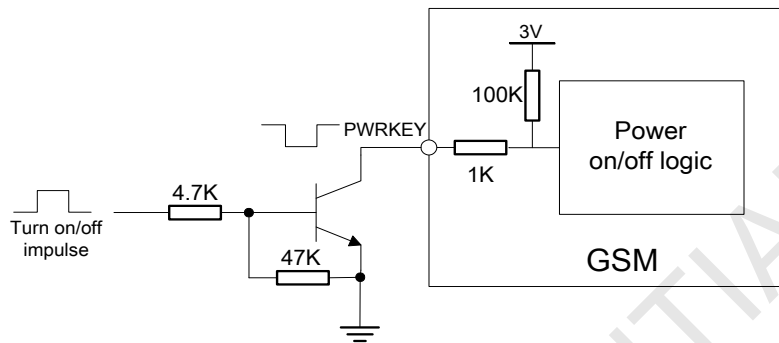

Figure 13: Powered on/off GSM using transistor

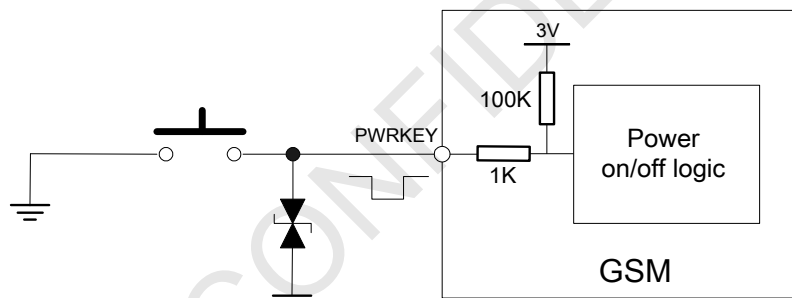

Figure 14: Powered on/off GSM using button

The power on timing is illustrated as Figure 15:

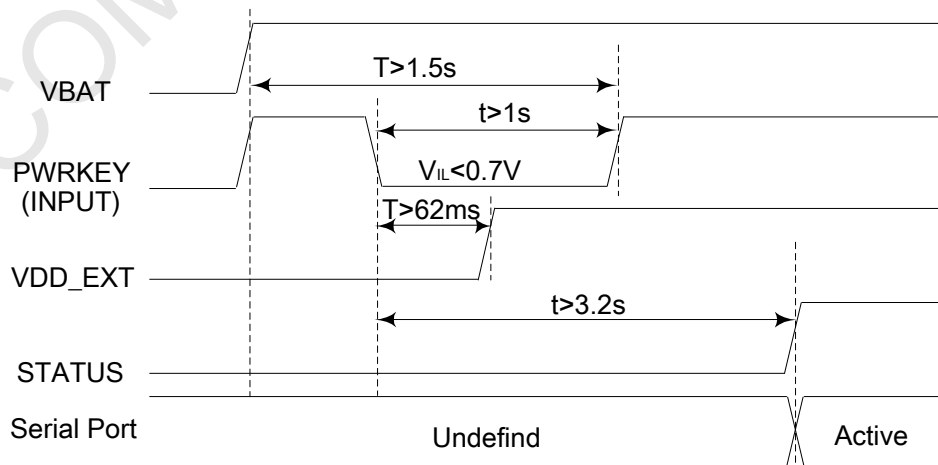

Figure 15: Timing of power on GSM

When power on procedure is completed, GSM will send following URC to indicate that the module is ready to

operate at fixed baud rate.

RDY

This URC does not appear when autobauding function is active.

Note: Customer can use AT command “AT+IPR=x” to set a fixed baud rate and save the configuration to non-volatile flash memory. After the configuration is saved as fixed baud rate, the Code “RDY” should be received from the serial port every time when SIM868 is powered on. For details, please refer to the chapter “AT+IPR” in document [1].

5.3.2. Power off GSM

GSM will be powered off in the following situations:

- Power off GSM by the PWRKEY pin.
- Power off GSM by AT command “AT+CPOWD=1”.

5.3.2.1. Power off GSM by the PWRKEY Pin

Customer can power off GSM by pulling down the PWRKEY pin for at least 1.5 second and release. The power off timing is illustrated in Figure 16.

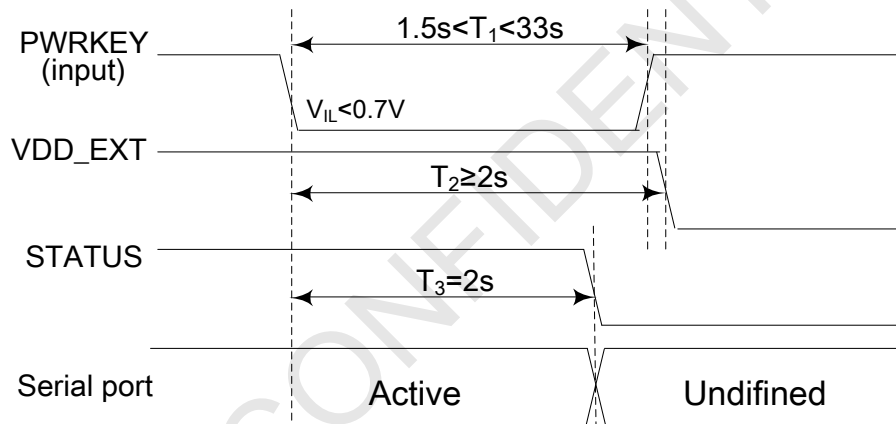

Figure 16: Timing of power off GSM

Note:

1. The GSM will restart after pulling down the PWRKEY over 33 seconds.
2. VDD_EXT will power off after STATUS changes into low level and the PWRKEY release 55ms.

If $1.5s < T_1 < 2s$, $T_2 > 2s$;

If $2s \leq T_1 < 33s$, $T_2 > T_1 + 55ms$

This procedure makes the GSM log off from the network and allows the software to enter into a secure state to save data before completely shut off.

Before the completion of the power off procedure, the GSM will send URC:

NORMAL POWER OFF

At this moment, AT commands can't be executed any more. Power off mode can also be indicated by STATUS pin, which is at low level at this time.

5.3.2.2. Power off GSM by AT Command

GSM can be powered off by AT command “AT+CPOWD=1”. This procedure makes the GSM log off from the network and allows the software to enter into a secure state to save data before completely shut off.

Before the completion of the power off procedure, the GSM will send URC:

NORMAL POWER OFF

At this moment, AT commands can't be executed any more. Power off mode can also be indicated by STATUS pin, which is at low level at this time.

For detail about AT command "AT+CPOWD", please refer to document [1].

5.3.2.3. Restart GSM by PWRKEY:

When the GSM works normally, if the customer wants to restart the GSM, follow the procedure as Figure 17:

- 1) Power off the GSM.
- 2) Wait for at least 800ms after STATUS pin changes to low level.
- 3) Power on the GSM.

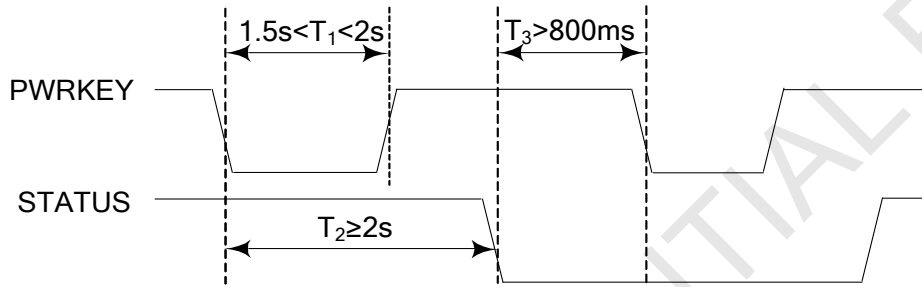

Figure 17: Timing of restart GSM

5.4. Power Saving Mode of GSM

GSM has two power saving modes: Minimum functionality mode and sleep mode. AT command "AT+CSCLK=1" can be used to set GSM into sleep mode. AT command "AT+CFUN=<fun>" can be used to set GSM into minimum functionality. When GSM is in sleep mode and also in minimum functionality mode, the current of GSM is the lowest.

5.4.1. Minimum Functionality Mode of GSM Part

There are three functionality modes, which could be set by AT command "AT+CFUN=<fun>". The command provides the choices of the functionality levels <fun>=0, 1, 4.

- AT+CFUN=0: Minimum functionality
- AT+CFUN=1: Full functionality (default)
- AT+CFUN=4: Flight mode (disable RF function)

Table 8: The current consumption of Function Mode

<fun>	BS-PA-MFRMS	Current consumption(mA)
0	/	0.65
1	9	0.86
	5	1.02
	2	1.42
4	/	0.69

Minimum functionality mode minimizes the current consumption to the lowest level. If GSM is set to minimum functionality mode by "AT+CFUN=0", the RF function and SIM card function will be disabled. In

this case, the serial port is still accessible, but partial AT commands and correlative to RF function and SIM card function will not be accessible.

For detailed information about AT command “AT+CFUN=<fun>“, please refer to document [1].

5.4.1.1. Sleep Mode 1 (AT+CSCLK=1)

Customer can control GSM to enter or exit the sleep mode (AT+CSCLK=1) by DTR signal. When DTR is in high level and without interrupt (on air and hardware such as GPIO interrupt or data in serial port), GSM will enter sleep mode automatically. In this mode, GSM can still receive paging or SMS from network but the serial port is not accessible.

5.4.1.2. Wake Up GSM from Sleep Mode 1

When GSM is in sleep mode 1(AT+CSCLK=1), the following methods can wake up the GSM:

- Pull down DTR pin
The serial port will be active after DTR pin is pulled to low level for about 50ms
- Receive a voice or data call from network
- Receive a SMS from network
- Receive external interrupt

Note: After module has received incoming call or new SMS, serial port can report URC, but it cannot input AT command. Only after the DTR pin is pulled to low level for 50ms, the serial port can input AT command.

5.4.1.3. Sleep Mode 2 (AT+CSCLK=2)

In this mode, GSM will continuously monitor the serial port data signal. When there is no data transfer over 5 seconds on the RXD signal and there is no on air and hardware interrupts (such as GPIO interrupt), GSM will enter sleep mode 2 automatically. In this mode, GSM can still receive paging or SMS from network.

5.4.1.4. Wake Up GSM from Sleep Mode 2

When GSM is in sleep mode 2 (AT+CSCLK=2), the following methods can wake up the module:

- Send data to GSM via main serial port (the first character will lose).
- Receive a voice or data call from network.
- Receive a SMS from network.

Note: Autobauding is default. It cannot enter sleep mode in the absence of synchronous serial port baud rate after GSM power on.

5.5. Serial Port of GSM

GSM default provides one unbalanced asynchronous serial port and one three-line serial port.

Table 9: Serial port pin definition

	Pin name	Pin number	Function
Serial port	UART1_DTR	6	Data terminal ready
	UART1_RI	7	Ring indicator
	UART1_DCD	5	Data carrier detect
	UART1_CTS	4	Clear to send
	UART1_RTS	3	Request to send

UART1_TXD	1	Transmit data
UART1_RXD	2	Receive data
UART2_TXD	22	Transmit data
UART2_RXD	23	Receive data

Note: Hardware flow control is disabled by default. AT command “AT+IFC=2, 2” can enable hardware flow control. AT command “AT+IFC=0,0” can disable hardware flow control. For more details please refer to document [1].

Table 10: Serial port characteristics

Symbol	Min	Max	Unit
V _{IL}	-0.3	0.7	V
V _{IH}	2.1	3.0	V
V _{OL}	-	0.4	V
V _{OH}	2.4	-	V

5.5.1. Function of Serial Port

Serial port:

- Full mode device.
- Contain data lines UART1_TXD/UART1_RXD; hardware flow control lines UART1_RTS/UART1_CTS, status lines UART1_DTR, UART1_DCD and UART1_RI.
- Serial port can be used for GPRS service and AT communication.
- Autobauding supports the following baud rates:
1200, 2400, 4800, 9600, 19200, 38400, 57600 and 115200bps

Autobauding allows GSM to automatically detect the baud rate of the host device. Pay more attention to the following requirements:

- **Synchronization between DTE and DCE:**
When DCE powers on with autobauding enabled, it is recommended to send "AT" or "at" or "aT" or "At" to synchronize the baud rate, until DTE receives the "OK" response, which means DTE and DCE are correctly synchronized. For more information please refer to AT command "AT+IPR".
- **Restrictions of autobauding operation:**
The DTE serial port must be set at 8 data bits, no parity and 1 stop bit.
The URC such as "RDY", "+CFUN: 1" and "+CPIN: READY" will not be reported.

Note: Customer can use AT command “AT+IPR=x” to set a fixed baud rate and the setting will be saved to non-volatile flash memory automatically. After the configuration is set as fixed baud rate, the URC such as “RDY”, “+CFUN: 1” and “+CPIN: READY” will be reported when GSM is powered on.

5.5.2. Serial Interfaces

The following figure shows the connection between GSM and client (DTE).

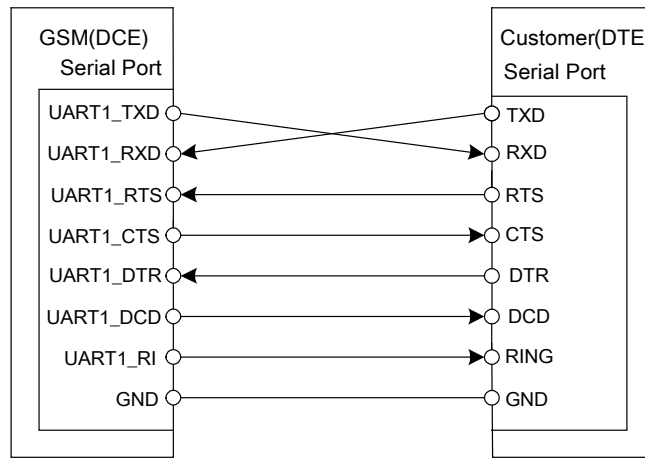

Figure 18: Connection of the serial interfaces

If the voltage of UART is 3.3V, the following reference circuits are recommended. If the voltage is 3.0V, please change the resistors in the following figure from 5.6K to 14K.

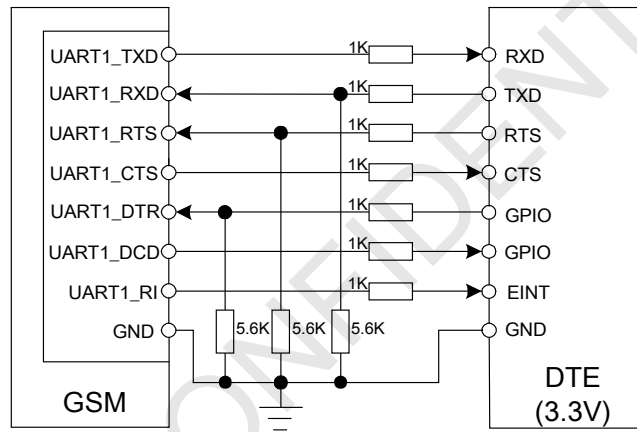

Figure 19: Resistor matching circuit

If the voltage of UART is 3V or 3.3V, the following reference circuit is recommended:

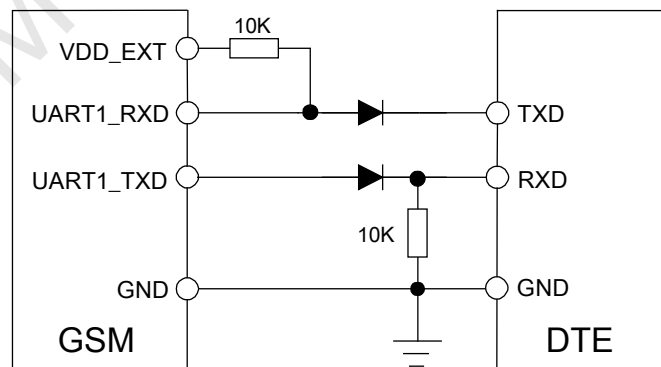

Figure 20 : Diode isolation circuit

Note: Please make sure the minimum of client high limit should be less than 2.8V minus the diode drop.

If the voltage of UART is 5V, the following reference circuit is recommended:

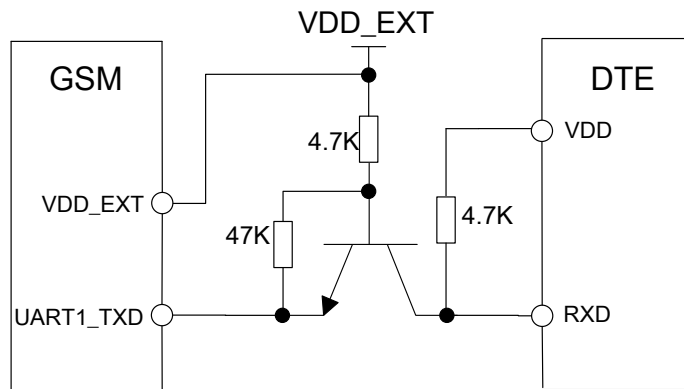

Figure 21: TX level matching circuit

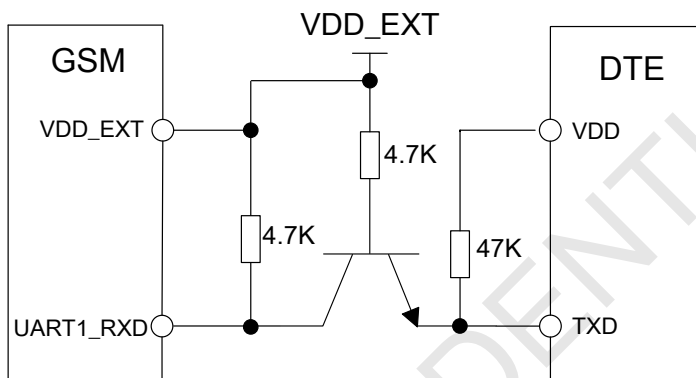

Figure 22: RX level matching circuit

5.5.3. Debug Interface

GSM could be debugged through USB port. The recommended diagram is shown as Figure 23:

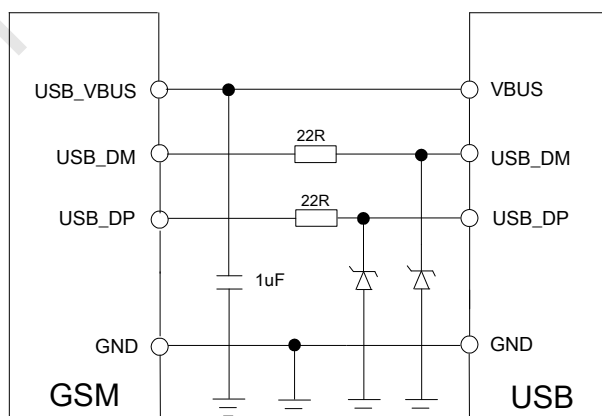

Figure 23: USB reference circuit

The TVS on USB data line should be less than 5pF, and the USB signals have to be layout according to differential signal layout rules.

Note: Please reserve the USB interface or test point for further debugging.

Table 11: USB_VBUS operation voltage

Pin	Min	Typ	Max	Unit
USB_VBUS	4.3	5.0	7.0	V

5.5.4. Software Upgrade of GSM

Customer could upgrade module’s GSM part firmware through USB or UART interface.

If upgrading GSM part through USB interface, it is necessary to connect USB_VBUS, USB_DP, USB_DM, and GND to PC. There is no need to operate PWRKEY pin in the whole procedure, when GSM detects USB_VBUS and can communicate normally with USB_DP and USB_DM, it will enter USB download mode automatically.

If customer upgrades GSM through UART interface, it is strongly recommended to lead the UART1_TXD, UART1_RXD, GND and PWRKEY pin to IO connector for the upgrading, and PWRKEY pin should be connected to GND while upgrading. Refer to Figure 24 for debugging and upgrading software.

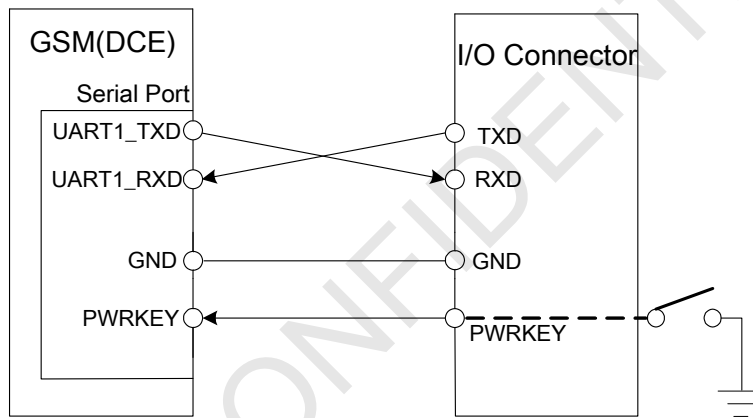

Figure 24: Connection for software upgrading

The UART interface supports the CMOS level. If customer connects the module to the computer, the level shift should be added between the DCE and DTE.

5.6. UART1_RI Behaviors

Table 12: UART_RI behaviours

State	RI response
Standby	High
Voice call	The pin is changed to low. When any of the following events occur, the pin will be changed to high: (1) Establish the call (2) Hang up the call
SMS	The pin is changed to low, and kept low for 120ms when a SMS is received. Then it is changed to high.
Others	For more details, please refer to <i>document [2]</i> .

The behavior of the RI pin is shown in the following figure when the module is used as a receiver.

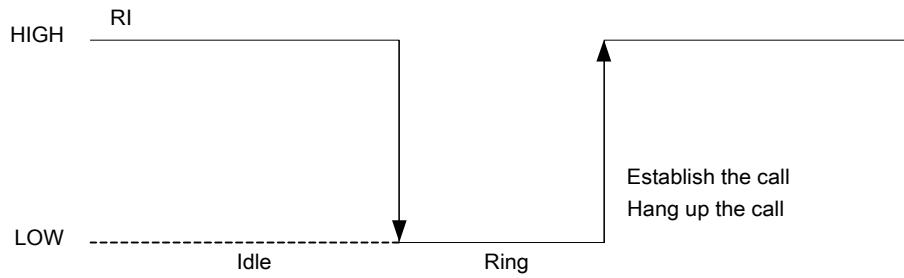

Figure 25: UART1_RI behaviour of voice calling as a receiver

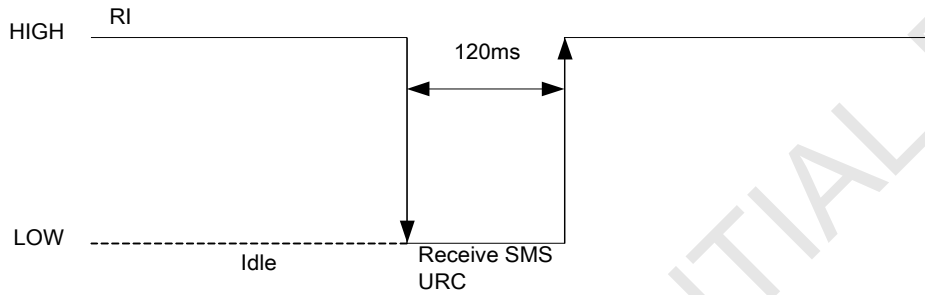

Figure 26: UART1_RI behaviour of URC or receive SMS

However, if the module is used as caller, the UART1_RI will remain high. Please refer to Figure 27.

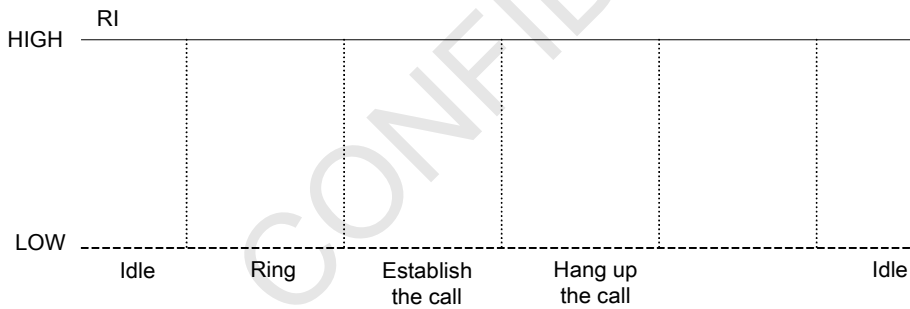

Figure 27: UART1_RI behaviour as a caller

5.7. Audio Interfaces

GSM part provides an analog input (MICP; MICN), which could be connected to electric microphone. The module also provides two analog audio outputs (SPK1P/1N; SPK2P/2N).

Table 13: Audio interface definition

Pin name	Pin number	Function
MICP	9	Audio input positive
MICN	10	Audio input negative
SPK1P	11	Audio output positive
SPK1N	12	Audio output negative
SPK2P	44	Audio output positive

SPK1P/1N output can directly drive 32Ω receiver.

SPK2P/2N output can directly drive 8Ω speaker, which integrates class-AB audio amplifier as shown Table 14:

Table 14: Performance of audio amplifier

Test Conditions	Class-AB AMP
4.2V 8Ω THD+N=1%	0.87W
3.3V 8Ω THD+N=1%	0.53W
4.2V 8Ω THD+N=10%	1.08W
3.3V 8Ω THD+N=10%	0.65W

AT command “AT+CMIC” is used to adjust the input gain level of microphone. AT command “AT+SIDET” is used to set the side-tone level. In addition, AT command “AT+CLVL” is used to adjust the output gain level. For more details, please refer to *document [1]*.

In order to improve audio performance, the following reference circuits are recommended. The audio signals have to be layout according to differential signal layout rules as shown in Figure 28 and Figure 29.

5.7.1. Speaker Interfaces Configuration

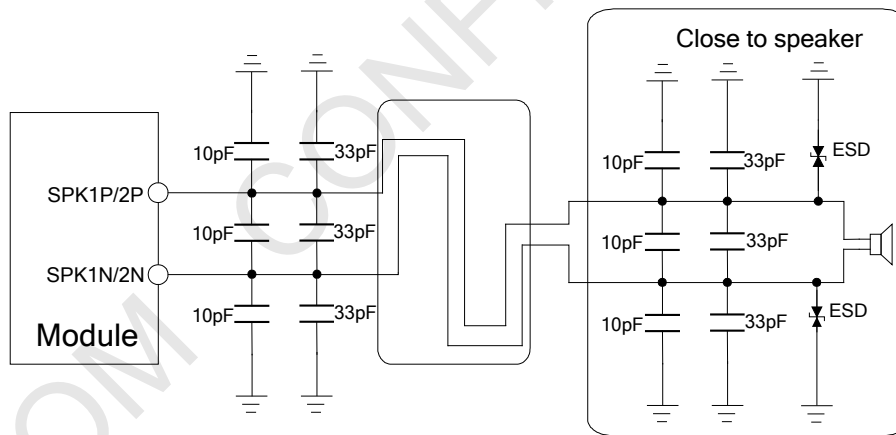

Figure 28: Speaker reference circuit

5.7.2. Microphone Interfaces Configuration

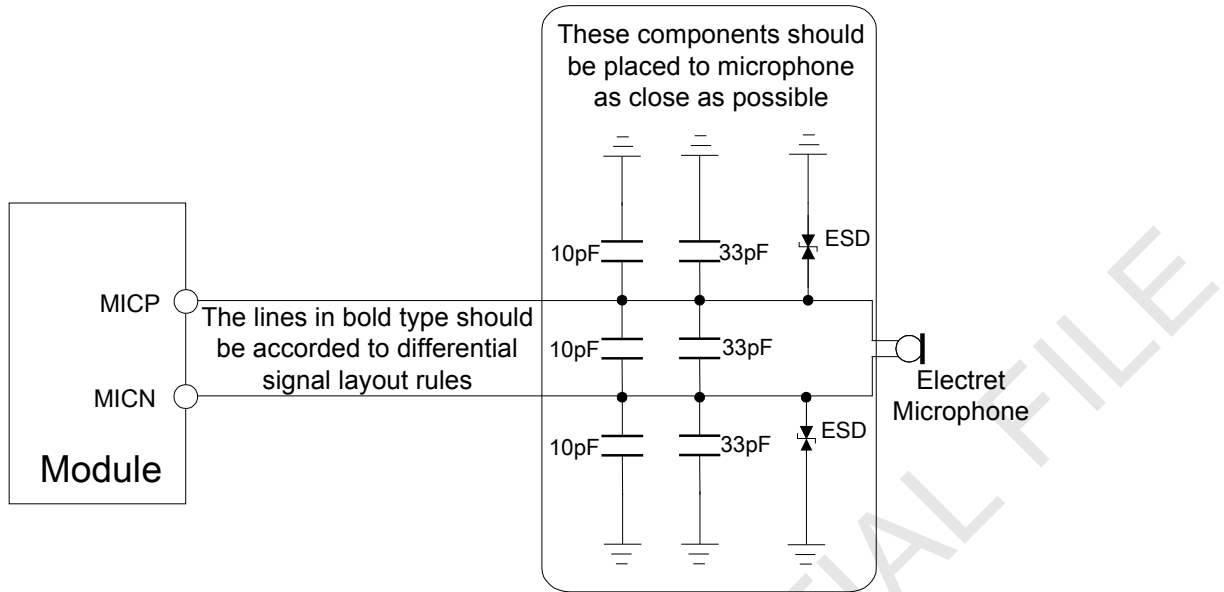

Figure 29: Microphone reference circuit

5.7.3. Audio Electronic Characteristic

Table 15: Microphone input characteristics

Parameter	Min	Typ	Max	Unit
Microphone biasing voltage	-	1.9	2.2	V
Working current	-	-	2.0	mA
Input impedance(differential)	13	20	27	K Ω
Idle channel noise	-	-	-67	dBm0
SINAD	Input level:-40dBm0	29	-	dB
	Input level:0dBm0	-	69	dB

Table 16: Audio output characteristics

Parameter	Conditions	Min	Typ	Max	Unit
Normal output	R _L =32 Ω receiver	-	15	90	mW
	R _L =8 Ω speaker	-	-	1080	mW

5.7.4. TDD Noise of GSM

Audio signal could be interfered by RF signal. Coupling noise could be filtered by adding 33pF and 10pF capacitor to audio lines. 33pF capacitor could eliminate noise from GSM850/EGSM900MHz, while 10pF capacitor could eliminate noise from DCS1800/PCS1900Mhz frequency. Customer should adjust this filter solution according to field test result.

GSM antenna is the key coupling interfering source of TDD noise. Thereat, pay attention to the layout of audio lines which should be far away from RF cable, antenna and GSM_VBAT pin. The bypass capacitor for filtering should be placed near module.

Conducting noise is mainly caused by the GSM_VBAT drop. If audio PA is powered by GSM_VBAT directly, then there will be some cheep noise from speaker output easily. So it is better to put big capacitors and ferrite beads near audio PA input.

TDD noise is related to GND signal. If GND plane is not good, lots of high-frequency noises will interfere microphone and speaker over bypass capacitor.

5.8. SIM Card Interface

The SIM interface complies with the GSM Phase 1 specification and the new GSM Phase 2+ specification for FAST 64kbps SIM card. Both 1.8V and 3.0V SIM card are supported. The SIM interface is powered from an internal regulator in the module.

5.8.1. SIM Card Application

Table 17: SIM pin definition

Pin name	Pin number	Function
SIM1_VDD	18	Voltage supply for SIM card. Support 1.8V or 3V SIM card
SIM1_DATA	15	SIM data input/output
SIM1_CLK	16	SIM clock
SIM1_RST	17	SIM reset
SIM1_DET	14	SIM card detection
SIM2_VDD	56	Voltage supply for SIM card. Support 1.8V or 3V SIM card
SIM2_DATA	53	SIM data input/output
SIM2_CLK	54	SIM clock
SIM2_RST	55	SIM reset
SIM2_DET	52	SIM card detection

It is recommended to use an ESD protection component such as ST (www.st.com) ESDA6V1-5W6 or ON SEMI (www.onsemi.com) SMF05C. The SIM card peripheral components should be placed close to the SIM card holder. The reference circuit of the 8-pin SIM card holder is illustrated in Figure 30.

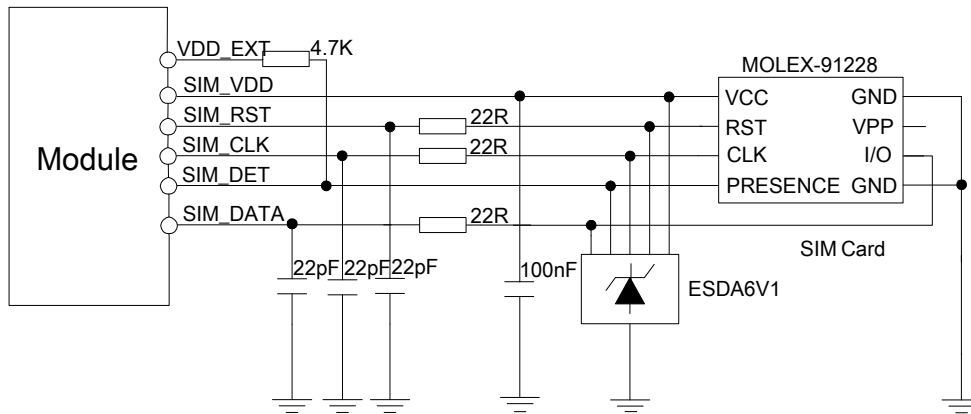

Figure 30: Reference circuit of the 8-pin SIM card holder

The SIM_DET pin is used for detection of the SIM card hot plug in. Customer can select the 8-pin SIM card holder to implement SIM card detection function. AT command “AT+CSDT” is used to enable or disable SIM card detection function. For details of this AT command, please refer to document [1]. If the SIM card detection function is not used, customer can keep the SIM_DET pin open. The reference circuit of 6-pin SIM card holder is illustrated in the Figure 31.

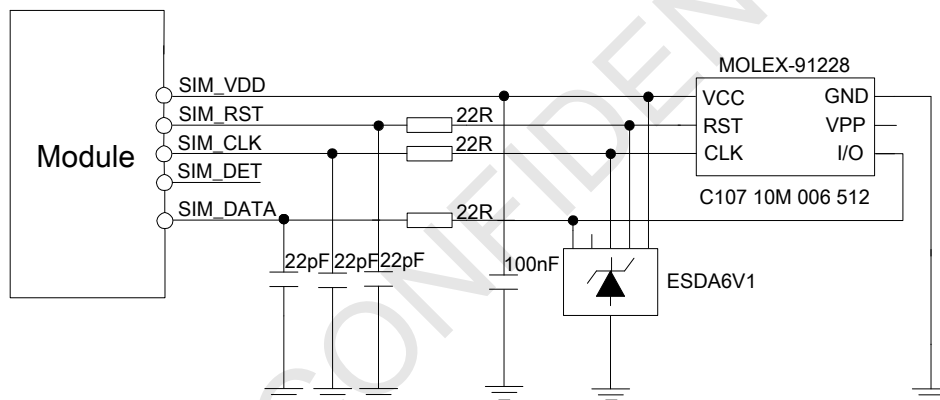

Figure 31: Reference circuit of the 6-pin SIM card holder

5.8.2. SIM Card Design Guide

SIM card signal could be interfered by some high frequency signal, it is strongly recommended to follow these guidelines while designing:

- SIM card holder should be far away from GSM antenna
- SIM traces should keep away from RF lines, GSM_VBAT and high-speed signal lines
- The traces should be as short as possible
- Keep SIM card holder’s GND connect to main ground directly
- Shielding the SIM card signal by ground well
- Recommend to place a 100nF capacitor on SIM_VDD line and keep it close to the SIM card holder
- Add some TVS with parasitic capacitance should not exceed 50pF
- Add 22R resistors to (SIM_RST/SIM_CLK/SIM_DATA) signal could enhance ESD protection
- Add 22pF capacitors to (SIM_RST/SIM_CLK/SIM_DATA) signal to reduce RF interference

5.8.3. Design Considerations for SIM Card Holder

For 8-pins SIM card holder, SIMCom recommends to use Molex 91228. Customer can visit <http://www.molex.com> for more information about the holder.

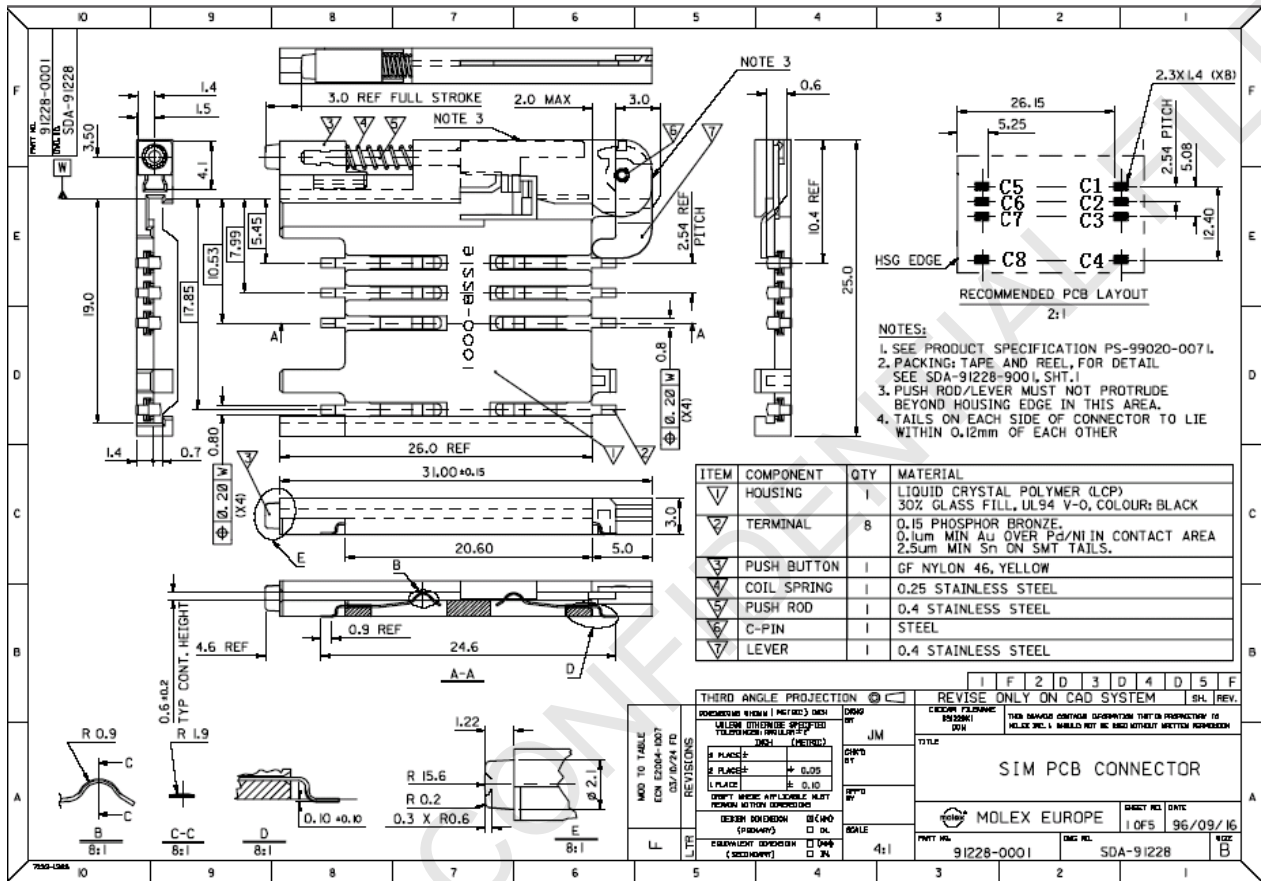

Figure 32: Molex 91228 SIM card holder

Table 18: Pin description (Molex SIM card holder)

Pin name	Signal	Description
C1	SIM_VDD	SIM card power supply
C2	SIM_RST	SIM card reset
C3	SIM_CLK	SIM card clock
C4	GND	Connect to GND
C5	GND	Connect to GND
C6	VPP	Not connect
C7	SIM_DATA	SIM card data I/O
C8	SIM_DET	Detect SIM card presence

For 6-pin SIM card holder, SIMCom recommends to use Amphenol C707 10M006 512 .Customer can visit <http://www.amphenol.com> for more information about the holder.

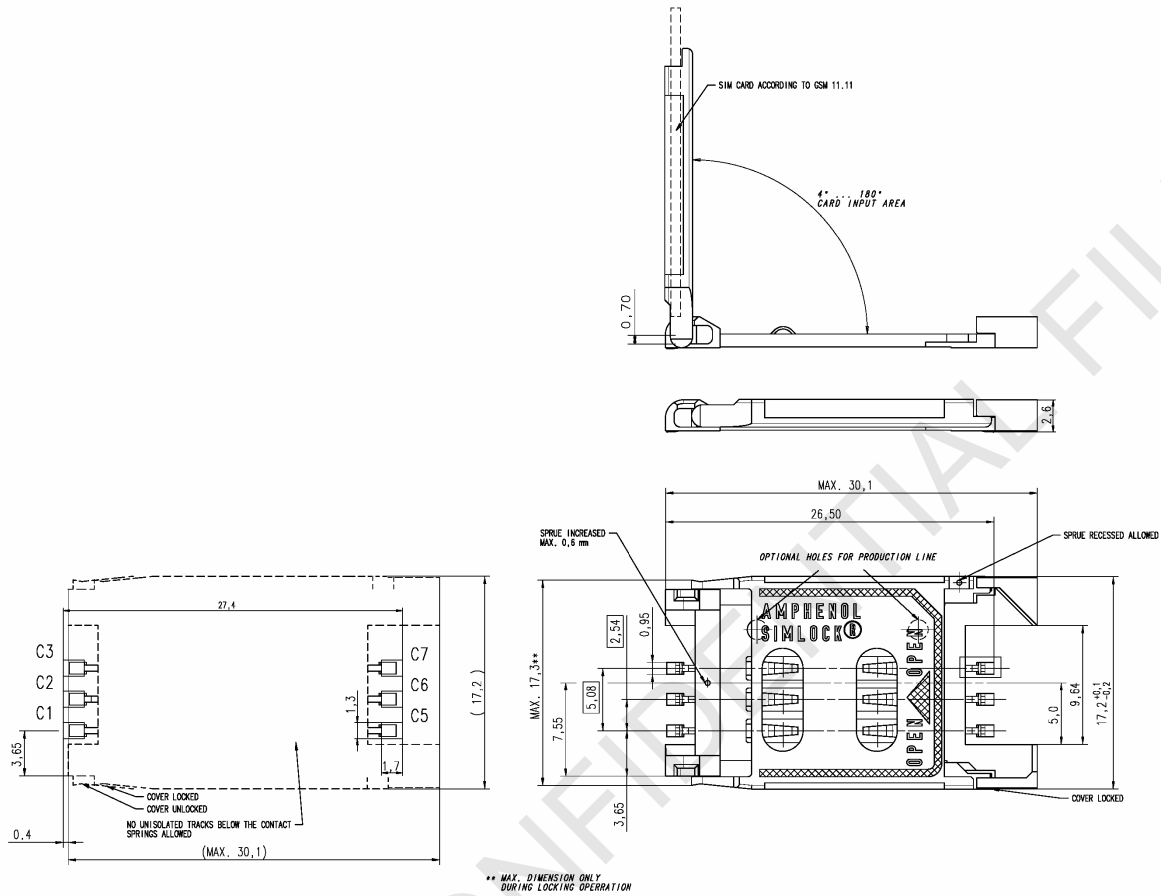

Figure 33: Amphenol C707 10M006 512 SIM card holder

Table 19: Pin description (Amphenol SIM card holder)

Pin name	Signal	Description
C1	SIM_VDD	SIM card power supply
C2	SIM_RST	SIM card reset
C3	SIM_CLK	SIM card clock
C5	GND	Connect to GND
C6	VPP	Not connect
C7	SIM_DATA	SIM card data I/O

Note: The interval time of removing and plugging SIM card should be greater than 2s. Otherwise may not detect correctly.

5.9. SD Interface

The reference circuit is recommended in Figure 34:

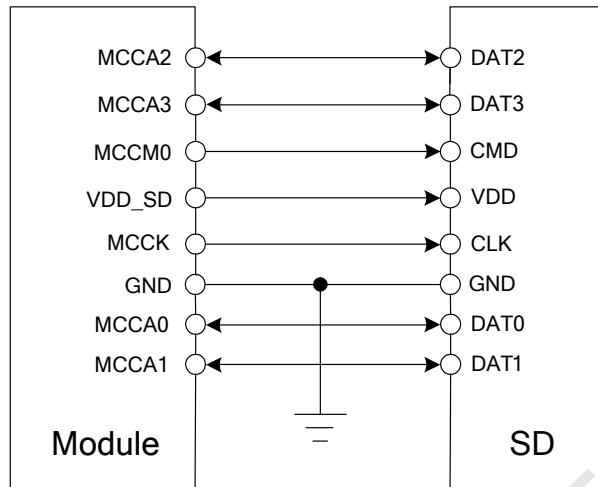

Figure 34: SD reference circuit

If the power supply is 2.8V for SD card, customer can use VDD_EXT; if the power supply is 3.3V, please use external LDO.

5.10. I2C Bus

The SIM868 provides an I2C interface which is only used in the embedded AT application.

Table 20: Pin definition of the I2C

Pin name	Pin number	Description
SCL	65	I2C serial bus clock(open drain output)
SDA	64	I2C serial bus data(open drain output)

Note:

1. I2C should be pulled up to 2.8V via 4.7K resistor externally.
2. I2C function is not supported in the standard firmware. If you need, please contact SIMCom.

5.11. ADC

Table 21: Pin definition of the ADC

Pin name	Pin number	Description
ADC	38	Analog voltage input

SIM868 provides an auxiliary ADC, which can be used to measure the voltage. Customer can use AT command “AT+CADC” to read the voltage value.

Note: Customer can use AT command set mode. For details, please refer to document [1].

Table 22: ADC specification

Parameter	Min	Typ	Max	Unit
Voltage range	0	-	2.8	V
ADC Resolution	-	10	-	bits
Sampling rate	-	-	1.08	MHz
ADC precision		10	30	mV

5.12. Network Status Indication

Table 23: Pin definition of the NETLIGHT

Pin name	Pin number	Description
NETLIGHT	41	Network Status Indication

The NETLIGHT pin can be used to drive a network status indication LED. The status of this pin is listed in following table:

Table 24: Status of the NETLIGHT

Status	SIM868 behavior
Off	Powered off
64ms On/ 800ms Off	Not registered the network
64ms On/ 3000ms Off	Registered to the network
64ms On/ 300ms Off	GPRS communication is established

Reference circuit is recommended in Figure 35:

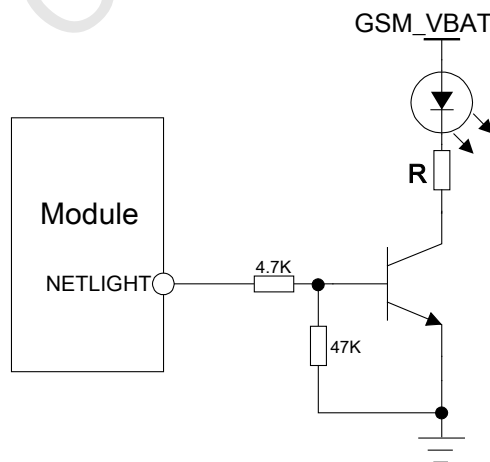

Figure 35: Reference circuit of NETLIGHT

Note: Customer can use AT command set mode. For details, please refer to document [1].

5.13. Operating Status Indication

The pin42 is for operating status indication of the module. The pin output is high when module is powered on

and low when module is powered off.

Table 25: Pin definition of the STATUS

Pin name	Pin number	Description
STATUS	42	Operating status indication

Note: For timing about STATUS, please refer to the chapter “Power on/off GSM Part”

5.14. RF Synchronization Signal

The synchronization signal serves to indicate GSM transmit burst.

Table 26: Definition of the RF_SYNC pin

Pin name	Pin number	Description
RF_SYNC	29	Transmit synchronization signal

RF sync signal is raised to high level 220us prior to GSM transmit burst, and changed to low level at the end of the GSM transmit burst. The timing of the RF sync signal is shown in Figure 35.

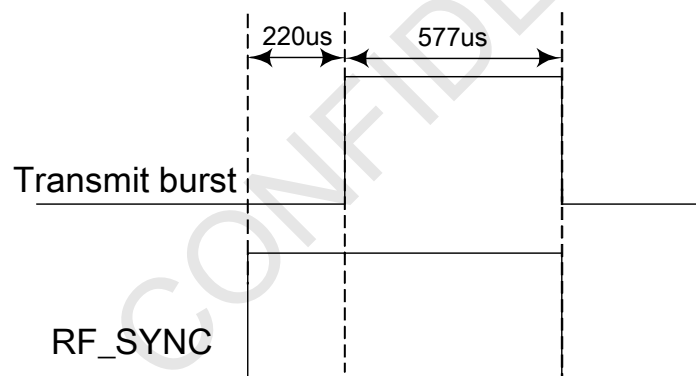

Figure 36: RF_SYNC signal during transmit burst

5.15. Antenna Interface of GSM

Antenna interface of GSM:

- The input impedance of the antenna should be 50Ω, and the VSWR should be less than 2.
- It is recommended that the GSM antenna should be placed as far as possible.
- The isolation of the antenna should be bigger than 30dB

Note: About RF design, please refer to document [15], [16] for more information.

The GSM antenna pad named GSM_ANT which is connected to an external GSM antenna, the connection of the antenna must be decoupled from DC voltage. This is necessary because the antenna connector is DC coupled to ground via an inductor for ESD protection. The external antenna must be matched properly to achieve the best performance, so the matching circuit is necessary.

It is recommended to reserve the matching circuit as following:

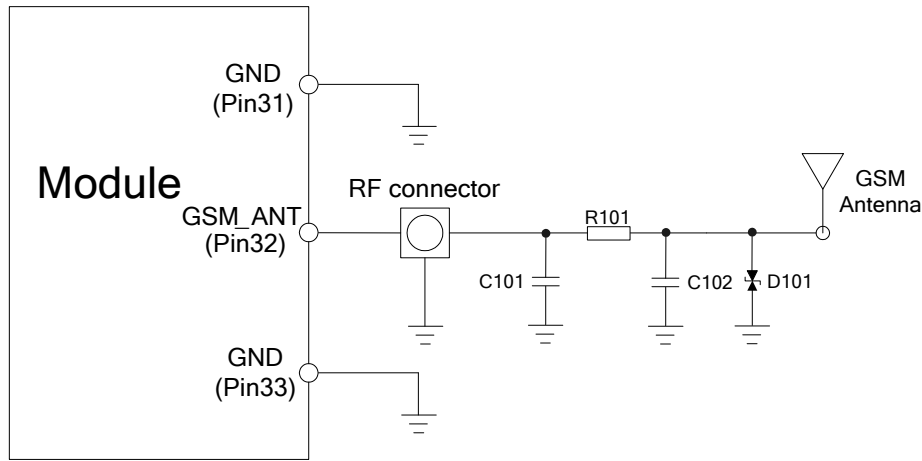

Figure 37: GSM antenna matching circuit

The RF connector is used for conduction test. If the space between RF pin and antenna is not enough, the matching circuit should be designed as in the following figure:

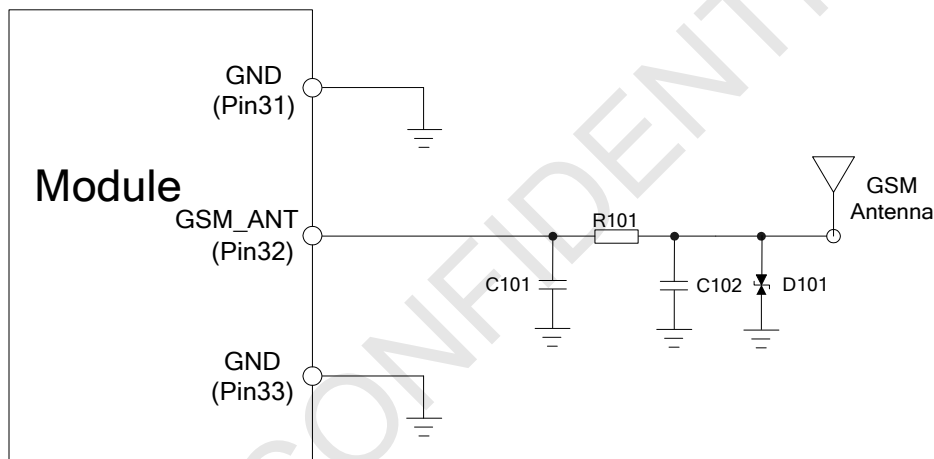

Figure 38: GSM antenna matching circuit without RF connector

In above figure, the components R101, C101 and C102 are used for antenna matching, the value of the components can only be got after the antenna tuning, usually, they are provided by antenna vendor. By default, the R101 is 0 Ω resistor, and the C101, C102 are reserved for tuning.

The RF test connector in the figure is used for the conducted RF performance test, and should be placed close to the module’s antenna pin. The traces impedance between components must be controlled in 50 Ω. The component D101 is a bidirectional TVS component, which is used for ESD protection, the recommended part numbers of the TVS are listed in the Table 27:

Table 27: Recommended TVS component

Package	Type	Supplier
0201	LXES03AAA1-154	Murata
0402	LXES15AAA1-153	Murata

6. Application Interface of GNSS

6.1. GNSS Overview

SIM868 provides a high-performance L1 GNSS solution for cellular handset applications. The solution offers best-in-class acquisition and tracking sensitivity, Time-To-First-Fix (TTFF) and accuracy. The GNSS supports both fully-autonomous operations for handheld consumer navigation devices and other standalone navigation systems.

For GNSS part Performance, please refer to Table 3.

GNSS NMEA outputs through serial port. The default baud rate is 9600/115200bps. (Determine by firmware)

6.2. Power Supply of GNSS

The power supply range of GNSS is from 2.9V to 4.4V. Recommended voltage is 4.0V. The power supply must be able to provide sufficient current up to 200mA. For the GPS_VBAT input, a bypass capacitor (low ESR) such as a 10 μ F and a 100nF capacitor are strongly recommended.

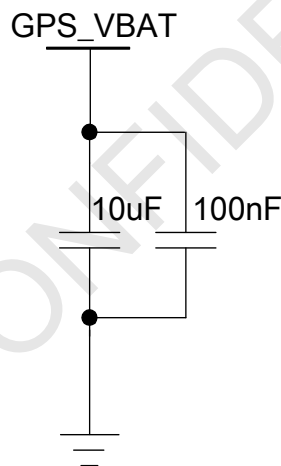

Figure 39: Reference circuit of the GPS_VBAT input

6.3. Backup Power of GNSS

Power source (such as battery or LDO) connected to VRTC pin will help the GNSS chipset keep its internal RTC running while the main power source is turned off, this will help to short the cold start time. The voltage should be kept between 2.3~4.3V, and the typical value is 3.0V.

- Rechargeable battery backup

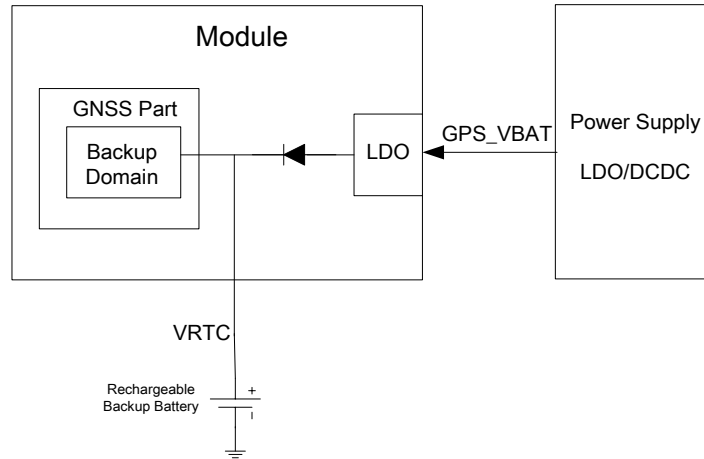

Figure 40: RTC supply from rechargeable battery

- External Power

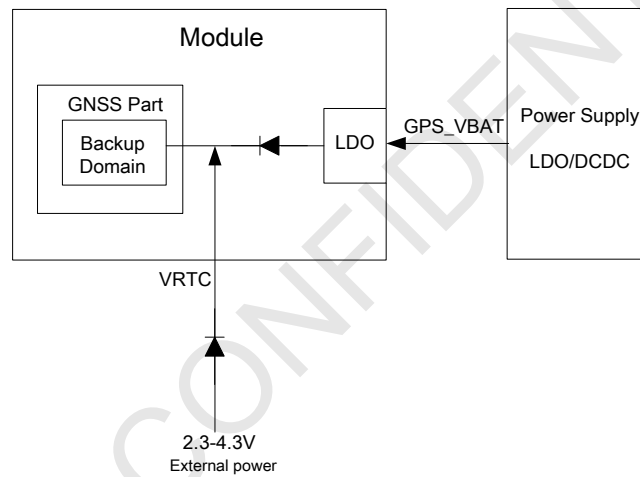

Figure 41: RTC supply from external power

6.4. Power on/off GNSS

The GNSS is controlled by GNSS_EN pin. The GNSS_EN should be pulled up to high (1.5-4.4V) through a 10k resistor to power on the GNSS, and be pulled to low (0-0.3V) to power off GNSS.

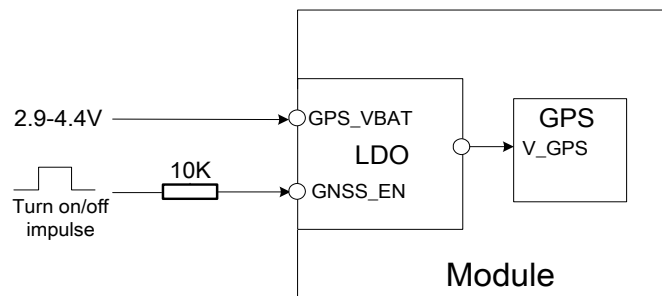

Figure 42: Power on/off GNSS

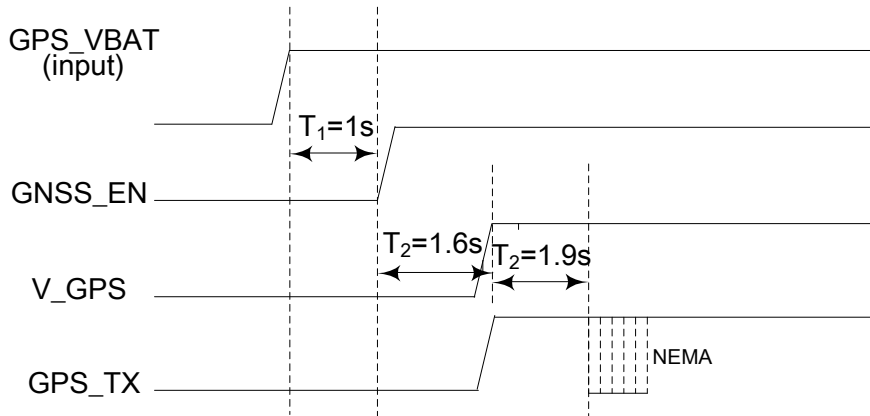

Figure 43: Timing of power on GNSS

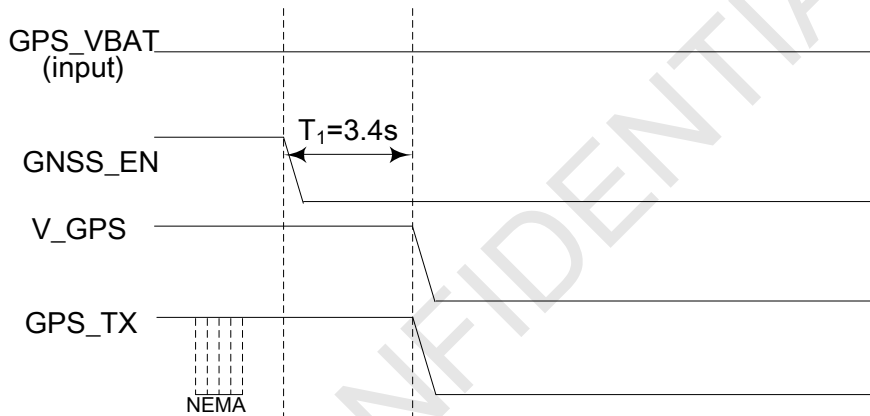

Figure 44: Timing of power off GNSS

6.5. Serial Port of GNSS

GNSS UART interface support NMEA output and PMTK command input.

Table 28: Serial port pin definition

	Pin name	Pin number	Function
Serial port	GPS_TXD	61	Transmit data
	GPS_RXD	62	Receive data

Table 29: Serial port characteristics

Symbol	Min	Max	Unit
V _{IL}	-0.3	0.7	V
V _{IH}	2.1	3.0	V
V _{OL}	-	0.4	V

V _{OH}	2.4	-	V
-----------------	-----	---	---

6.6. Software Upgrade of GNSS

GNSS firmware can be upgraded through UART interface.

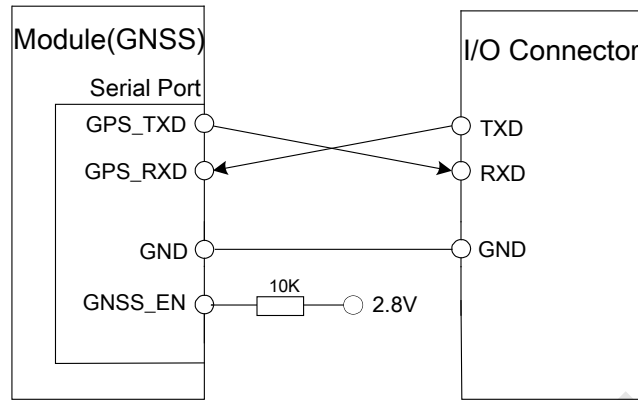

Figure 45: Connection for software upgrading and debugging for GNSS

If customer upgrades GSM and GNSS part in all-in-one mode, the GNSS UART should be connected to GSM UART2; GNSS_EN must be connected to GPIO1 of GSM part through 10K resistance. Thus customer could upgrade the module through UART1 or USB port of GSM.

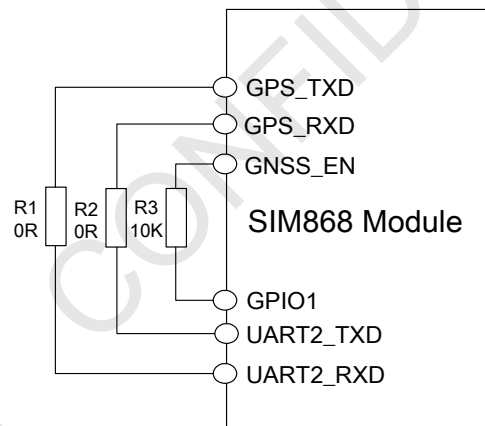

Figure 46: Connection for software upgrading in all-in-one Mode

Note: GNSS_EN must be connected to GPIO1 of GSM part

6.7. 1PPS Output

The 1PPS pin outputs pulse-per-second signal for precise timing purposes after the position has been fixed. The 1PPS signal can be provided through designated output pin for many external applications. This pulse is not only limited to be active every second but also allowed to set the required duration, frequency, and active high/low by programming user-defined settings.

Figure 47 is the typical application of the 1PPS function:

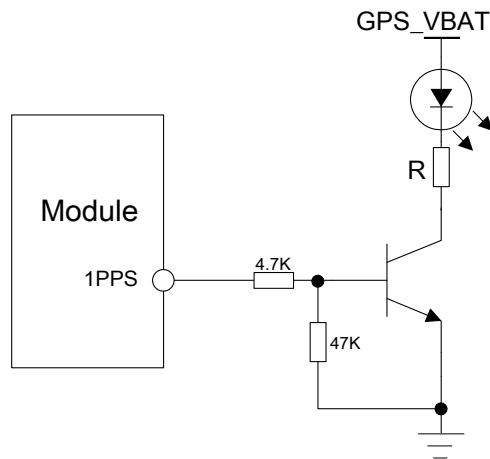

Figure 47: 1PPS Application circuit

6.8. Antenna Interface

Antenna interface of GNSS:

- The input impedance of the antenna should be 50Ω , and the VSWR should be less than 2.
- It is recommended that the GNSS antenna should be placed as far as possible to other antenna.
- The isolation of the antenna should be more than 30dB

Note: About RF design, please refer to document [15], [16] for more information.

6.8.1. Passive Antenna

Passive antenna contains only the radiating element, e.g.: the ceramic patch, the helix structure, and chip antennas. Sometimes it also contains a passive matching network to match the electrical connection to 50Ω impedance.

The most common antenna type for GPS/GLONASS application is the patch antenna. Patch antennas are flat, generally have a ceramic and metal body and are mounted on a metal base plate.

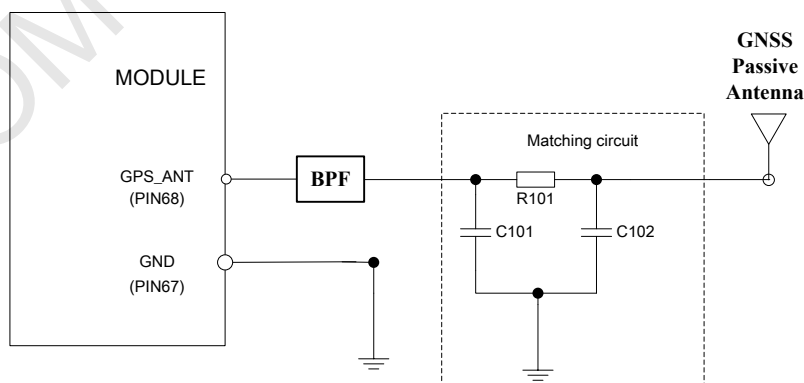

Figure 48: GNSS passive antenna matching circuit

The components R101, C101 and C102 are used for antenna matching, the BPF is used for out of band noise signal suppression. The components' value only can be got after the antenna tuning. Normally R101 is 0Ω , C101 and C102 are not mounted.

6.8.2. Active Antenna

Active antenna has an integrated Low-Noise Amplifier (LNA). VCC_ANT is needed on customer’s application board for the active antenna power input, as shown in Figure 49.

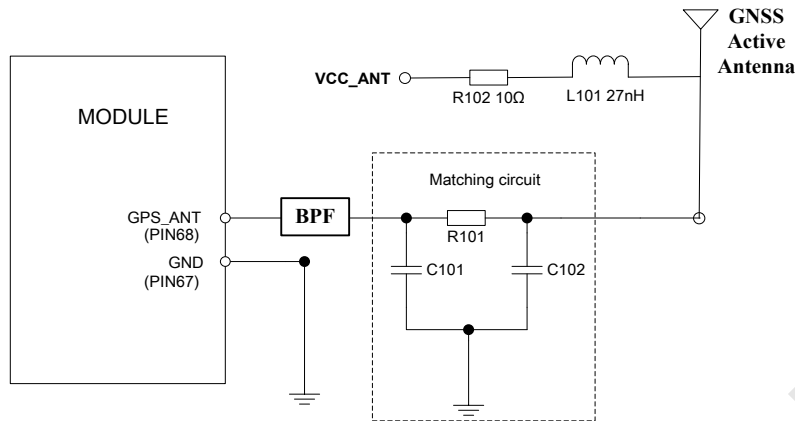

Figure 49: GNSS active antenna matching circuit

The inductor L101 is used to prevent the RF signal from leaking into the VCC_ANT pass and route the bias supply to the active antenna, the recommended value of L101 is no less than 27nH. R102 can protect the whole circuit in case the active antenna is shorted to ground.

Table 30: Recommended BPF component

Package	Type	Supplier
1.10*0.90	SAFFB1G56KB0F0A	Murata

6.9. Operation Modes of GNSS

GNSS supports operating modes like full on mode, stop mode, backup mode, periodic mode, AlwaysLocate™ mode and GLP mode.

- Full on mode: In this mode, the GNSS will enter full on mode after first power up. Power consumption will vary depending on the amount of satellite acquisitions and number of satellites in track.

Table 31: Default configuration of GNSS (full on mode)

Item	Configuration	Comment
Baud rate	Depend on firmware	9600/115200bps
GNSS	GPS+GLONASS	GPS/BEIDOU/GLONASS
Update rate	1Hz default	10Hz Max
SBAS	Enable	
AIC	Enable	

Note: The GNSS modes mentioned above are set by PMTK commands. The PMTK commands for multiple position chosen are illustrated as below:

*\$PMTK353,1,0,0,0,0*2A (GPS only)*

*\$PMTK353,0,0,0,0,1*2A (BEIDOU only)*

\$PMTK353,0,1,0,0,0*2A (GLONASS only)
\$PMTK353,1,1,0,0,0*2B (GPS+GLONASS)
\$PMTK353,1,0,0,0,1*2B (GPS+BEIDOU)

Customer can refer to document [13] for more information.

- Stop mode: Stop mode means a low quiescent (590uA typ) power state and a PMTK command can be used to enter. Any character input will exit from stop mode.

Note: Using the PMTK161 command to enter stop mode: "\$PMTK161,0*28"

Customer can refer to document [13] for more information.

- Backup mode: In this mode, the power source (such as battery) is connected to VRTC pin, which will help to keep its internal RTC running when the GPS_VBAT is turned off. The VRTC power must be kept active all the time, the GNSS module will perform a quick start every power-on. Backup mode has lower power consumption than stop mode. The power consumption in this mode is about 8uA.
- Periodic mode: In this mode, periodic control power on/off of GPS to reduce power consumption.
"\$PMTK225,(Type),(Run time),(Sleep time),(Second run time),(Second sleep time)*15"

Note: Using the PMTK225 command to set periodic mode:

Periodic backup mode:

"\$PMTK225,0*2B"

"\$PMTK223,1,25,180000,60000*38"

"\$PMTK225,1,3000,12000,18000,72000*15"

Periodic stop mode:

"\$PMTK225,0*2B"

"\$PMTK223,1,25,180000,60000*38"

"\$PMTK225,2,3000,12000,18000,72000*15"

Customer can refer to document [13] for more information.

- AlwaysLocate™ mode: AlwaysLocate™ is an intelligent controller of GNSS periodic mode. Depending on the environment and motion conditions, GNSS can adaptive adjust the on/off time to achieve balance of positioning accuracy and power consumption.

Note: Using the PMTK225 command to set AlwaysLocate™ mode.

AlwaysLocate™ Stop mode:

"\$PMTK225,0"

"\$PMTK225,8"

AlwaysLocate™ Backup mode:

"\$PMTK225,0"

"\$PMTK225,9"

Customer can refer to document [13] for more information.

- GLP mode: The power consumption is lower in GLP (GNSS low power) mode. GNSS can be waked up when the host sends the command through the communication interface.

GLP mode is to achieve 1Hz NMEA output and power saving, switch the Measurement Engine (DSP) and

Positioning Engine (ARM) on/off. In GLP mode, the active time (on time) of Measurement Engine (DSP) and Positioning Engine (ARM) should be adjusted dynamically according to GNSS signal.

Note: Using the PMTK262 command to enable/disable GLP mode:

"\$PMTK262,3" Enable GLP mode;

"\$PMTK262,0" Disable GLP mode;

Customer can refer to document [13] for more information.

6.10. A-GPS

A-GPS means assisted GPS, which is a system that can improve the startup performance and time-to-first-fix (TTFF) of a GNSS satellite-based positioning under certain conditions. GNSS part supports EPO file, EASY MODE and SBAS.

6.10.1. Easy Mode

Easy is the abbreviation of Embedded Assist System, it works as embedded firmware which accelerates TTFF by predicting satellite navigation messages from received ephemeris.

No additional computing interval for Easy task. Easy is efficiently scheduled and computed in free time of every second after GNSS navigation solution.

Easy function is conceptually designed to automatically engage for predicting after first receiving the broadcast ephemeris. After a while (generally tens of seconds), 3-day extensions will be completely generated then all Easy functions will be maintained at a standby condition. Easy assistance is going to be engaged when the GNSS requests in new TTFF condition or re-generates again with another new received ephemeris. Meanwhile, TTFF will be benefited by Easy assistance.

Note: The modes mentioned above can be set by PMTK commands; customer can refer to document [13] for more information.

6.10.2. EPO

GNSS supports the EPO (Extended Prediction Orbit) data service. The EPO data service supports 7/14/30 days orbit prediction to customers. It needs to download aiding information from EPO server, which includes ephemeris, almanac, rough last position, time, satellite status and an optional time synchronization signal. This function will reduce time of first fixing significantly and improving the acquisition sensitivity. Customer should update the EPO files from EPO server daily through the GSM part.

Note: The modes mentioned above can be set by PMTK commands; customer can refer to document [13] for more information.

6.11. Fast-Fix

The Fast-Fix technology is based on the latest EPO data. Fast-Fix online provides extra time aiding from NITZ

or NTP, which could reduce TTF and acquisition sensitivity in cold start.

6.12. Multi-tone AIC

SIM868 module supports Multi-tone AIC (active interference canceller) to suppress the RF noise from GSM, Wi-Fi and so on.

With the help of AIC function, The GNSS signal could be demodulated from the jammed signal, which can ensure better navigation quality. AIC function is enabled by default. Enabling AIC function will increase extra current consumption

Note: Using the PMTK286 command to enable/disable AIC function:

*Enable AIC function: \$PMTK286,1*23*

*Disable AIC function: \$PMTK286,0*22*

6.13. SBAS

SBAS is the abbreviation of Satellite Based Augmentation System. The SBAS concept is based on the transmission of differential corrections and integrity messages for navigation satellites that are within sight of a network of reference stations deployed across an entire continent. SBAS messages are broadcast via geostationary satellites that are able to cover vast areas.

Several countries have implemented their own satellite-based augmentation system. Europe has the European Geostationary Navigation Overlay Service (EGNOS) which covers Western Europe and beyond. The USA has its Wide Area Augmentation System (WAAS). Japan is covered by its Multi-functional Satellite Augmentation System (MSAS). India has launched its own SBAS program named GPS and GEO Augmented Navigation (GAGAN) to cover the Indian subcontinent.

7. PCB Layout

This section provides some guidelines on PCB layout, in order to eliminate interference or noise.

7.1. Pin Assignment

Before PCB layout, we should learn about pin assignment in order to get reasonable layout with so many external components. Figure 50 is the overview of pin assignment of the module.

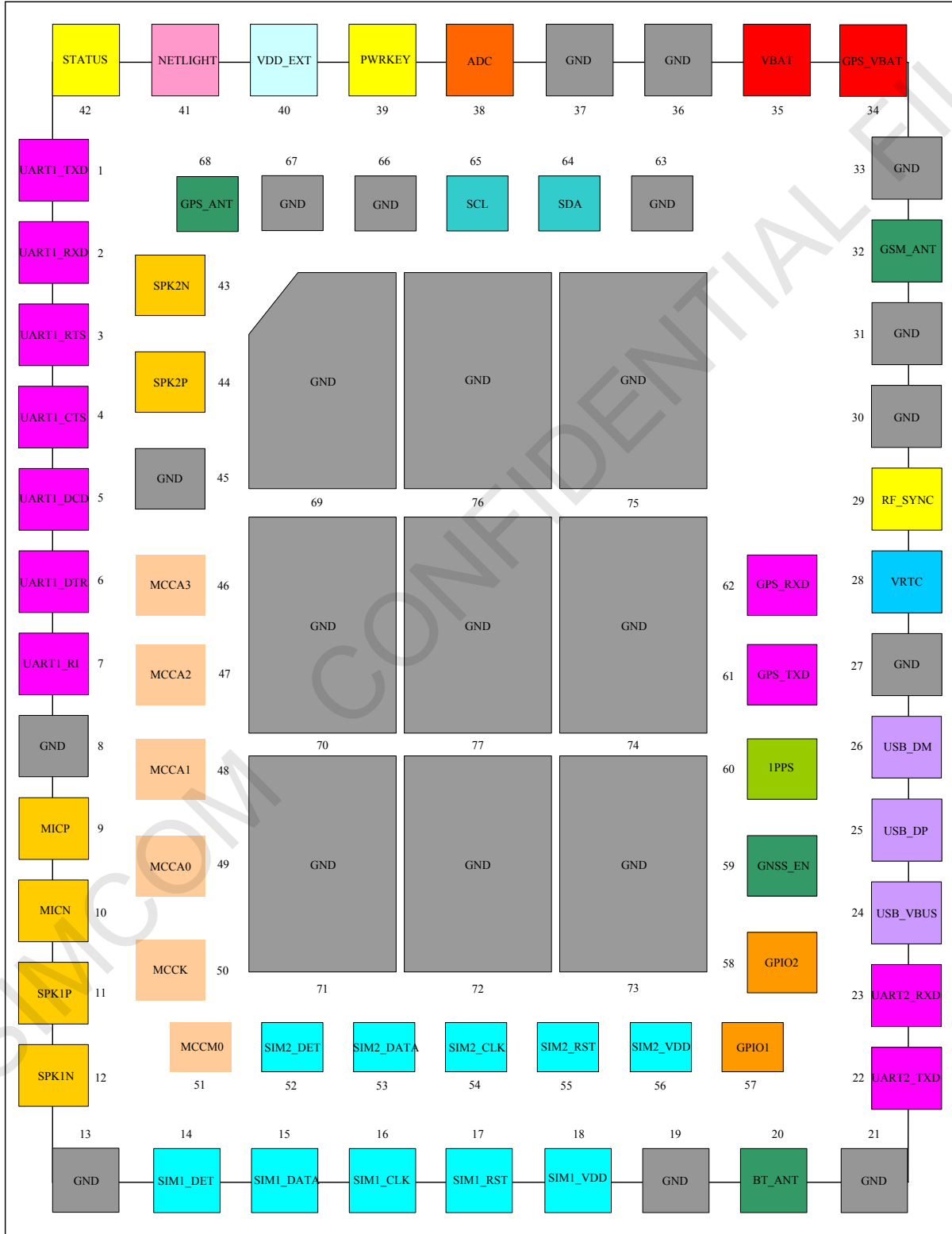

Figure 50: PIN assignment

7.2. Principle of PCB Layout

7.2.1. Antenna Interface

- Antenna interface used for RF conducting test such as coaxial cable pad, RF connector should be placed close to RF_IN pad.
- RF trace should be as short and direct as possible.
- Keep the impedance of RF traces as 50Ω;
- Avoid any other signal crossing or parallel directly under the RF trace.

7.2.2. Power Supply

- VBAT and GND are very important in layout.
- The VBAT trace should be as short and wide as possible.
- Zener diode and capacitor should be placed close to VBAT pin.
- The trace of pin 36 and pin37 to main GND should be as short and wide as possible.

7.2.3. SIM Card Interface

- Ensure SIM card holder is far away from antenna or RF cable to avoid high power interference of GSM transmitter.
- Put SIM card holder near the module.
- Add ESD component to protect SIM_CLK, SIM_DATA, SIM_RST and SIM_VDD signals.
- All the signals should be far away from power and high-speed-frequency signal.
- The length of signals should be less than 100mm.

7.2.4. Audio Interface

- The signal trace of audio should be far away from antenna
- The signal trace of audio should not parallel to VBAT
- The audio trace are surrounded with GND

8. Electrical, Reliability and Radio Characteristics

8.1. Absolute Maximum Ratings

The absolute maximum ratings stated in Table 32 are stress ratings under non-operating conditions. Stresses beyond any of these limits will cause permanent damage to SIM868.

Table 32: Absolute maximum ratings

Symbol	Min	Typ	Max	Unit
GSM_VBAT	-	-	4.5	V
GPS_VBAT	-	-	4.5	
VRTC	-	-	4.5	
GNSS_EN	-	-	4.5	
Current (GSM_VBAT)	0	-	2.0	A
USB_VBUS	-	-	7	V
I _I *	-	4	16	mA
I _O *	-	4	16	mA

*These parameters are for digital interface pins, GPIO, and UART.

8.2. Recommended Operating Conditions

Table 33: Recommended operating conditions

Symbol	Parameter	Min	Typ	Max	Unit
GSM_VBAT	GSM power supply voltage	3.4	4.0	4.4	V
GPS_VBAT	GPS power supply voltage	2.9	4.0	4.4	
VRTC	Backup battery voltage	2.3		4.3	
GNSS_EN(V _{OH})	GPS enable	1.5	2.8	4.4	V
GNSS_EN(V _{OL})	GPS disable	-	-	0.3	V
T _{OPER}	Operating temperature	-40	+25	+85	°C
T _{STG}	Storage temperature	-45		+90	°C

8.3. Digital Interface Characteristics

Table 34: Digital interface characteristics

Symbol	Parameter	Min	Typ	Max	Unit
V _{IH}	High-level input voltage	2.1	-	3.0	V
V _{IL}	Low-level input voltage	-0.3	-	0.7	V
V _{OH}	High-level output voltage	2.4	-	-	V
V _{OL}	Low-level output voltage	-	-	0.4	V

Note: These parameters are for digital interface pins, such as GPIO and UART.

8.4. SIM Card Interface Characteristics

Table 35: SIM card interface characteristics

Symbol	Parameter	Min	Typ	Max	Unit
I _{IH}	High-level input current	-1.0	-	1.0	uA
I _{IL}	Low-level input current	-1.0	-	1.0	uA
V _{IH}	High-level input voltage	1.4	-	-	V
		2.4	-	-	V
V _{IL}	Low-level input voltage	-	-	0.27	V
		-	-	0.4	V
V _{OH}	High-level output voltage	1.62	-	-	V
		2.7	-	-	V
V _{OL}	Low-level output voltage	-	-	0.36	V
		-	-	0.4	V

8.5. SIM_VDD Characteristics

Table 36: SIM_VDD characteristics

Symbol	Parameter	Min	Typ	Max	Unit
V _O	Output voltage	-	3.0	-	V
		-	1.8	-	
I _O	Output current	-	-	10	mA

8.6. VDD_EXT Characteristics

Table 37: VDD_EXT characteristics

Symbol	Parameter	Min	Typ	Max	Unit
V _O	Output voltage	2.7	2.8	2.9	V
I _O	Output current	-	-	50	mA

8.7. Current Consumption (GSM_VBAT=4.0V)

Table 38: Current consumption

Symbol	Parameter	Conditions	Min	Typ	Max	Unit
GSM_VBAT	Voltage			4.0		V
	Power drop	PCL=5			350	mV
	Voltage ripple	PCL=5				

		@ f<200kHz			50	mV
		@ f>200kHz			2.0	mV
I _{GSM_VBAT}	Average current	Power off mode		130	150	uA
		Sleep mode (AT+CFUN=1): (BS-PA-MFRMS=9) (BS-PA-MFRMS=5) (BS-PA-MFRMS=2)		0.86		mA
				1.02		mA
				1.42		mA
		Idle mode (AT+CFUN=1): GSM850 EGSM900 DCS1800 PCS1900		13.7		mA
				13.7		mA
				13.7		mA
				13.7		mA
		Voice call (PCL=5): GSM850 EGSM900 Voice call (PCL=0): DCS1800 PCS1900		223		mA
				234		mA
				162		mA
				170		mA
		Data mode GPRS (1Rx,4Tx): GSM850 EGSM900 DCS1800 PCS1900		378		mA
				414		mA
	270			mA		
	308			mA		
Data mode GPRS (3Rx,2Tx): GSM850 EGSM900 DCS1800 PCS1900		323		mA		
		340		mA		
		212		mA		
		236		mA		
Data mode GPRS (4Rx,1Tx): GSM850 EGSM900 DCS1800 PCS1900		217		mA		
		223		mA		
		153		mA		
		163		mA		
I _{MAX}	Peak current	During Tx burst			2.0	A

Note: In Table 38 the current consumption value is the typical one of the module tested in laboratory. In the mass production stage, there may be differences among each individual.

8.8. Electro-Static Discharge

SIM868 is an ESD sensitive component, so attention should be paid to the procedure of handling and packaging. The ESD test results are shown in the following table.

Table 39: The ESD characteristics (Temperature: 25°C, Humidity: 45 %)

Pin name	Contact discharge	Air discharge
VBAT	±5KV	±10KV

GND	±5KV	±10KV
UART1_TXD /UART1_RXD	±4KV	±8KV
Antenna port	±5KV	±10KV
SPKP/SPKN/MICP/MICN	±4KV	±8KV
PWRKEY	±4KV	±8KV

8.9. Radio Characteristics

8.9.1. Module RF Output Power

The Table 40 shows the module conducted output power, it follows the 3GPP TS 05.05 technical specification requirement.

Table 40: GSM850 and EGSM900 conducted RF output power

GSM850, EGSM900			
PCL	Nominal output power (dBm)	Tolerance (dB) for conditions	
		Normal	Extreme
5	33	±2	±2.5
6	31	±3	±4
7	29	±3	±4
8	27	±3	±4
9	25	±3	±4
10	23	±3	±4
11	21	±3	±4
12	19	±3	±4
13	17	±3	±4
14	15	±3	±4
15	13	±3	±4
16	11	±5	±6
17	9	±5	±6
18	7	±5	±6
19-31	5	±5	±6

Table 41: DCS1800 and PCS1900 conducted RF output power

DCS1800,PCS1900			
PCL	Nominal output power (dBm)	Tolerance (dB) for conditions	
		Normal	Extreme
0	30	±2	±2.5
1	28	±3	±4
2	26	±3	±4
3	24	±3	±4

4	22	±3	±4
5	20	±3	±4
6	18	±3	±4
7	16	±3	±4
8	14	±3	±4
9	12	±4	±5
10	10	±4	±5
11	8	±4	±5
12	6	±4	±5
13	4	±4	±5
14	2	±5	±6
15	0	±5	±6

For the module’s output power, the following should be noted:

At GSM900 and GSM850 band, the module is a class 4 device, so the module’s output power should not exceed 33dBm, and at the maximum power level, the output power tolerance should not exceed +/-2dB under normal condition and +/-2.5dB under extreme condition.

At DCS1800 and PCS1900 band, the module is a class 1 device, so the module’s output power should not exceed 30dBm, and at the maximum power level, the output power tolerance should not exceed +/-2dB under normal condition and +/-2.5dB under extreme condition.

8.9.2. Module RF Receive Sensitivity

Table 42 shows the module’s conducted receiving sensitivity; it is tested under static condition.

Table 42: Conducted RF receive sensitivity

Frequency	Receive sensitivity (Typical)	Receive sensitivity(Max)
GSM850,EGSM900	< -109dBm	< -107dBm
DCS1800,PCS1900	< -109dBm	< -107dBm

8.9.3. Module Operating Frequencies

The Table 43 shows the module’s operating frequency range; it follows the 3GPP TS 05.05 technical specification requirement.

Table 43: Operating frequencies

Frequency	Receive	Transmit
GSM850	869 ~ 894MHz	824 ~ 849MHz
EGSM900	925 ~ 960MHz	880 ~ 915MHz
DCS1800	1805 ~ 1880MHz	1710 ~ 1785MHz
PCS1900	1930 ~ 1990MHz	1850 ~ 1910MHz

9. Manufacturing

9.1. Top and Bottom View of SIM868

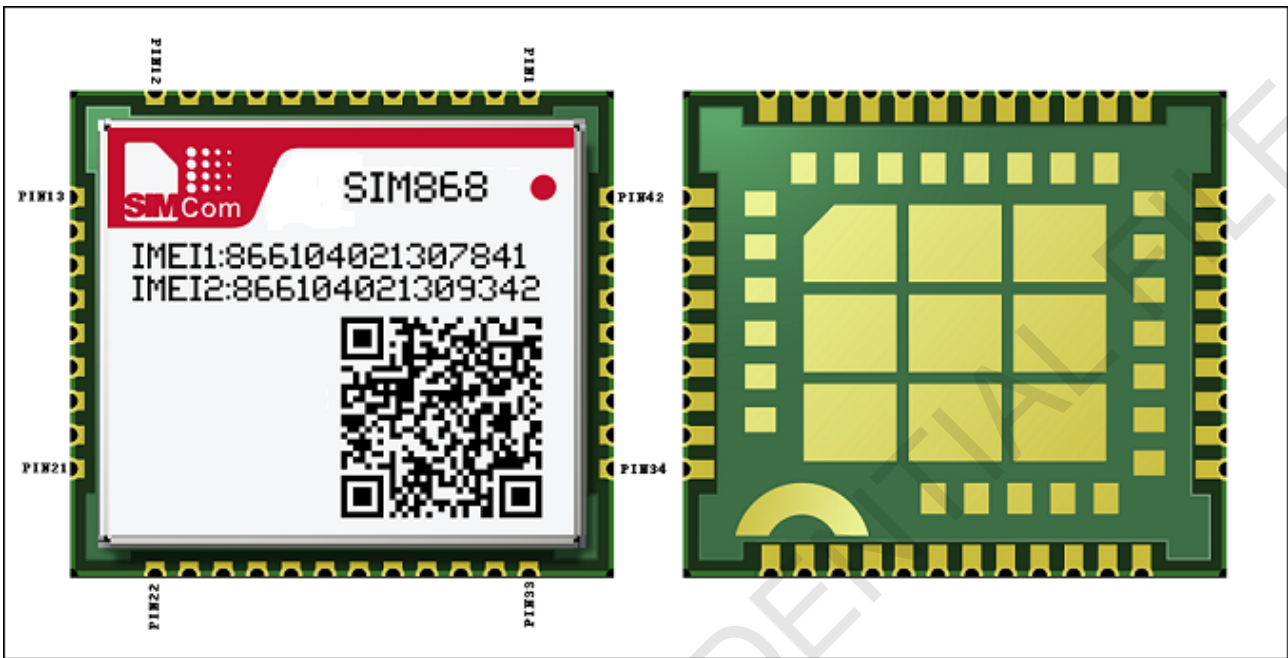

Figure 51: Top and bottom view of SIM868

9.2. Typical Solder Reflow Profile

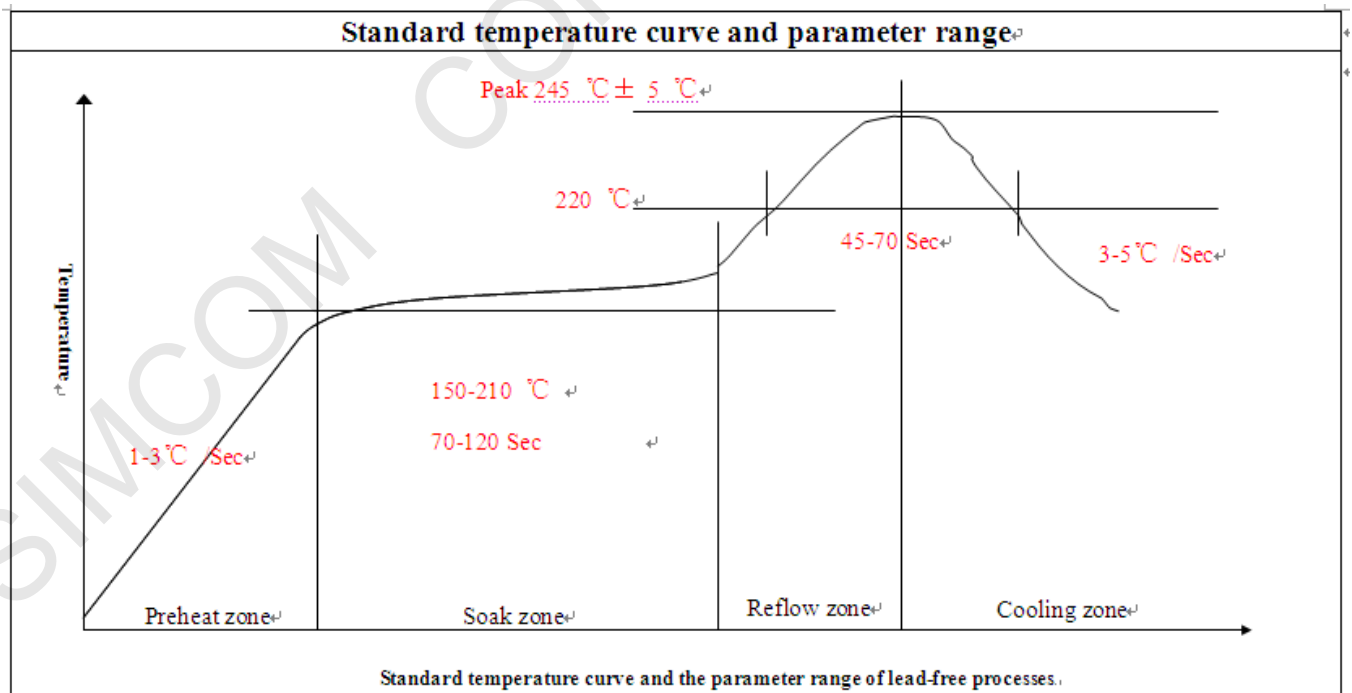

Figure 52: Typical solder reflow profile of lead-free process

9.3. The Moisture Sensitivity Level

The moisture sensitivity level of SIM868 module is 3. The modules should be mounted within 168 hours after unpacking in the environmental conditions of temperature <math><30^{\circ}\text{C}</math> and relative humidity of <math><60\% \text{ (RH)}</math>. It is necessary to bake the module if the above conditions are not met:

Table 44: Moisture sensitivity level and floor life

Moisture Sensitivity Level (MSL)	Floor Life (out of bag) at factory ambient $\leq 30^{\circ}\text{C}/60\% \text{ RH}$ or as stated
1	Unlimited at $\leq 30^{\circ}\text{C}/85\% \text{ RH}$
2	1 year
2a	4 weeks
3	168 hours
4	72 hours
5	48 hours
5a	24 hours
6	Mandatory bake before use. After bake, it must be reflowed within the time limit specified on the label.

NOTES:

- 1. If the vacuum package is not open for 3 months or longer than the packing date, baking is also recommended before re-flow soldering.*
- 2. For product handling, storage, processing, IPC / JEDEC J-STD-033 must be followed.*

9.4. Baking Requirements

SIM868 modules are vacuum packaged, and guaranteed for 6 months storage without opening or leakage under the following conditions: the environment temperature is lower than 40°C , and the air humidity is less than 90%.

If the condition meets one of the following ones shown below, the modules should be baked sufficiently before re-flow soldering, and the baking condition is shown in table below; otherwise the module will be at the risk of permanent damage during re-flow soldering.

- If the vacuum package is broken or leakage;
- If the vacuum package is opened after 6 months since it's been packed;
- If the vacuum package is opened within 6 months but out of its Floor Life at factory ambient $\leq 30^{\circ}\text{C} / 60\% \text{RH}$ or as stated.

Table 45: Baking requirements

Baking temperature	Moisture	Time
$40^{\circ}\text{C} \pm 5^{\circ}\text{C}$	<math><5\%</math>	192 hours
$120^{\circ}\text{C} \pm 5^{\circ}\text{C}$	<math><5\%</math>	4 hours

Note: Care should be taken if that plastic tray is not heat-resistant, the modules should be taken out for preheating, and otherwise the tray may be damaged by high-temperature heating.

10. Appendix

10.1. Related Documents

Table 46: Related documents

SN	Document name	Remark
[1]	SIM800_Series_AT_Command_Manual	
[2]	SIM800 Series UART Port Application Note_V1.01.doc	
[3]	SIM800 Series_TCPIP_Application Note_V1.02	
[4]	ITU-T Draft new recommendation V.25ter:	Serial asynchronous automatic dialing and control
[5]	GSM 07.07:	Digital cellular telecommunications (Phase 2+); AT command set for GSM Mobile Equipment (ME)
[6]	GSM 07.10:	Support GSM 07.10 multiplexing protocol
[7]	GSM 07.05:	Digital cellular telecommunications (Phase 2+); Use of Data Terminal Equipment – Data Circuit terminating Equipment (DTE – DCE) interface for Short Message Service (SMS) and Cell Broadcast Service (CBS)
[8]	GSM 11.14:	Digital cellular telecommunications system (Phase 2+); Specification of the SIM Application Toolkit for the Subscriber Identity Module – Mobile Equipment (SIM – ME) interface
[9]	GSM 11.11:	Digital cellular telecommunications system (Phase 2+); Specification of the Subscriber Identity Module – Mobile Equipment (SIM – ME) interface
[10]	GSM 03.38:	Digital cellular telecommunications system (Phase 2+); Alphabets and language-specific information
[11]	GSM 11.10	Digital cellular telecommunications system (Phase 2); Mobile Station (MS) conformance specification; Part 1: Conformance specification
[12]	AN_Serial Port	AN_Serial Port
[13]	SIM868_NMEA Message Specification_V1.00	
[14]	EPO-II_Format_Protocol_Customer	EPO-II_Format and Protocol
[15]	SIM868_RF_Design_Application Note	
[16]	AN_SMT Module_RF_Reference Design_Guide	

10.2. Terms and Abbreviations







Table 47: Terms and abbreviations

Abbreviation	Description
ADC	Analog-to-Digital Converter
AMR	Adaptive Multi-Rate
CS	Coding Scheme
CTS	Clear to Send
DTE	Data Terminal Equipment (typically computer, terminal, printer)
DTR	Data Terminal Ready
DTX	Discontinuous Transmission
EFR	Enhanced Full Rate
EGSM	Enhanced GSM
ESD	Electrostatic Discharge
ETS	European Telecommunication Standard
FR	Full Rate
GPRS	General Packet Radio Service
GSM	Global Standard for Mobile Communications
HR	Half Rate
MO	Mobile Originated
MS	Mobile Station (GSM part), also referred to as TE
MT	Mobile Terminated
PAP	Password Authentication Protocol
PBCCH	Packet Broadcast Control Channel
PCB	Printed Circuit Board
PCL	Power Control Level
PCS	Personal Communication System, also referred to as GSM 1900
PDU	Protocol Data Unit
PPP	Point-to-point protocol
RF	Radio Frequency
RMS	Root Mean Square (value)
RX	Receive Direction
SIM	Subscriber Identification Module
SMS	Short Message Service
TE	Terminal Equipment, also referred to as DTE
TX	Transmit Direction
SINAD	Signal to Noise and Distortion Ratio
UART	Universal Asynchronous Receiver & Transmitter
URC	Unsolicited Result Code
USSD	Unstructured Supplementary Service Data

A-GPS	Assisted Global Positioning System
CMOS	Complementary Metal Oxide Semiconductor
CEP	Circular Error Probable
GLP	GNSS Low Power
DGPS	Difference Global Positioning System
EEPROM	Electrically Erasable Programmable Read Only Memory
EPO	Extended Prediction Orbit
ESD	Electrostatic Sensitive Devices
EASY	Embedded Assist System
EGNOS	European Geostationary Navigation Overlay Service
GPS	Global Positioning System
GAGAN	The GPS Aided Geo Augmented Navigation
kbps	Kilo bits per second
MSL	moisture sensitive level
MSAS	Multi-Functional Satellite Augmentation System
NMEA	National Marine Electronics Association
PRN	Pseudo Random Noise Code
QZSS	Quasi-Zenith Satellites System
SBAS	Satellite Based Augmentation Systems
WAAS	Wide Area Augmentation System
Phonebook abbreviations	
FD	SIM fix dialing phonebook
LD	SIM last dialing phonebook (list of numbers most recently dialed)
MC	Mobile Equipment list of unanswered MT calls (missed calls)
ON	SIM (or ME) own numbers (MSISDNs) list
RC	Mobile Equipment list of received calls
SM	SIM phonebook
NC	Not connect

10.3. Safety Caution

Table 48: Safety caution

Marks	Requirements
	<p>When in a hospital or other health care facility, observe the restrictions about the use of mobiles. Switch the cellular terminal or mobile off, medical equipment may be sensitive to not operate normally for RF energy interference.</p>
	<p>Switch off the cellular terminal or mobile before boarding an aircraft. Make sure it is switched off. The operation of wireless appliances in an aircraft is forbidden to prevent interferes with communication systems. Forget to think much of these instructions may lead to the flight safety or offend against local legal action, or both.</p>
	<p>Do not operate the cellular terminal or mobile in the presence of flammable gases or fumes. Switch off the cellular terminal when you are near petrol stations, fuel depots, chemical plants or where blasting operations are in progress. Operation of any electrical equipment in potentially explosive atmospheres can constitute a safety hazard.</p>
	<p>Your cellular terminal or mobile receives and transmits radio frequency energy while switched on. RF interferes can occur if it is used close to TV sets, radios, computers or other electric equipment.</p>
	<p>Road safety comes first! Do not use a hand-held cellular terminal or mobile when driving a vehicle, unless it is securely mounted in a holder for hands free operation. Before making a call with a hand-held terminal or mobile, park the vehicle.</p>
	<p>GSM cellular terminals or mobiles operate over radio frequency signals and cellular networks and cannot be guaranteed to connect in all conditions, for example no mobile fee or a invalid SIM card. While you are in this condition and need emergent help, please remember using emergency calls. In order to make or receive calls, the cellular terminal or mobile must be switched on and in a service area with adequate cellular signal strength.</p> <p>Some networks do not allow for emergency call if certain network services or phone features are in use (e.g. lock functions, fixed dialing etc.). You may have to deactivate those features before you can make an emergency call.</p> <p>Also, some networks require that a valid SIM card be properly inserted in the cellular terminal or mobile.</p>

Contact us:**Shanghai SIMCom Wireless Solutions Co.,Ltd.**

Address: Building A, SIM Technology Building, No. 633, Jinzhong Road, Shanghai, P. R. China
200335

Tel: +86 21 3252 3300

Fax: +86 21 3252 3020

URL: www.simcomm2m.com

SIMCOM CONFIDENTIAL FILE