



SIM8200G

Hardware Design

5G Module

SIMCom Wireless Solutions Limited.

Building B, SIM Technology Building, No.633, Jinzhong Road

Changning District, Shanghai P.R.China

Tel: 86-21-31575100

support@simcom.com

www.simcom.com

Document Title:	SIM8200G Hardware Design
Version:	V1.13
Date:	2021-10-27
Status:	Released

GENERAL NOTES

SIMCOM OFFERS THIS INFORMATION AS A SERVICE TO ITS CUSTOMERS TO SUPPORT THE APPLICATION AND ENGINEERING EFFORTS THAT USE THE PRODUCTS DESIGNED BY SIMCOM. THE INFORMATION PROVIDED IS BASED ON THE REQUIREMENTS SPECIFICALLY FROM THE CUSTOMERS. SIMCOM HAS NOT UNDERTAKEN ANY INDEPENDENT SEARCH FOR ADDITIONAL RELEVANT INFORMATION, INCLUDING ANY INFORMATION THAT MAY BE IN THE CUSTOMER'S POSSESSION. FURTHERMORE, THE SYSTEM VALIDATION OF THE PRODUCT DESIGNED BY SIMCOM WITHIN A LARGER ELECTRONIC SYSTEM REMAINS THE RESPONSIBILITY OF THE CUSTOMER OR THE CUSTOMER'S SYSTEM INTEGRATOR. ALL SPECIFICATIONS SUPPLIED HEREIN ARE SUBJECT TO CHANGE WITHOUT NOTICE.

COPYRIGHT

THIS DOCUMENT CONTAINS THE PROPRIETARY TECHNICAL INFORMATION WHICH IS THE PROPERTY OF SIMCOM LIMITED, COPYING OF THIS DOCUMENT, GIVING IT TO OTHERS, THE USING OR COMMUNICATION OF THE CONTENTS THEREOF ARE FORBIDDEN WITHOUT THE OFFICIAL AUTHORITY BY SIMCOM. OFFENDERS ARE LIABLE TO THE PAYMENT OF THE DAMAGES. ALL RIGHTS ARE RESERVED IN THE EVENT OF GRANT OF A PATENT OR THE REGISTRATION OF A UTILITY MODEL OR DESIGN. ALL SPECIFICATIONS SUPPLIED HEREIN ARE SUBJECT TO CHANGE WITHOUT NOTICE.

SIMCom Wireless Solutions Limited

Building B, SIM Technology Building, No.633 Jinzhong Road, Changning District, Shanghai P.R.China

Tel: +86 21 31575100

Email:simcom@simcom.com

For more information, please visit:

<https://www.simcom.com/download/list-863-en.html>

For technical support, or to report documentation errors, please visit:

<https://www.simcom.com/ask/> or email to: support@simcom.com

Copyright © 2020 SIMCom Wireless Solutions Limited All Rights Reserved.

Version History

Date	Version	Description of change	Author
2019-09-18	V1.00	Initial release	Changshun Tan
2019-10-31	V1.01	Table 1: Pin Description add AH3 PIN	Changshun Tan
2020-06-12	V1.02	Modify the error Modify the format	Zhiqiang Liu Changshun Tan Cunbao Feng
2020-08-10	V1.03	Modify the error	Lijuan Yin
2020-09-01	V1.04	1.Update RF bands information in table 1 2.Update data transfer rate in table 2	Lijuan Yin Tao Tian
2020-10-12	V1.05	1.Modify the error	Lijuan Yin
2020-12-28	V1.06	1.Update commend of Table 5 2. Update Figure 10 and Table 10 3. Update layout guideline rules for USB、PCIe、SDIO、RGMII interface 4. Add and update some notes 5. Add test data in Table 54 6.Add and update power supply 7. Update RF Plug Recommendation	Changshun Tan Zhiqiang Liu Yuqing Xiong
2021-01-08	V1.07	1.Update Table 43	Ylbo Zhong
2021-02-25	V1.08	1.Update Antenna Tuner 2.Update Pin Description	Yuqing Xiong
2021-03-12	V1.09	1.Add TDD_SYNC_PPS signal 2.Add and update some notes 3.Update Pin description 4.Update WL_I2S description	Zhiqiang Liu
2021-04-13	V1.10	1.Update BB current consumption 2.Modify the error 3.Add PCIe to Ethernet	Zhiqiang Liu
2021-06-25	V1.11	1.Update Pin L47 description 2.Add PCIe Switch 3. Update Table5 Antenna interface	Zhiqiang Liu Qingling Wang
2021-08-20	V1.12	1.Modify the error	Zhiqiang Liu
2021-10-27	V1.13	1. Add 3.12 UART chapter note illustrate 2.Update table5 WALN I2S interface illustrate	Yao.Chen

Contents

1	Introduction.....	10
1.1	Product Outline.....	10
1.2	Hardware Block Diagram.....	11
1.3	Feature Overview.....	11
2	Package Information.....	14
2.1	Pin Assignment Overview.....	14
2.2	Pin Description.....	15
2.3	Mechanical Dimensions.....	25
3	Interface Application.....	26
3.1	Power Supply.....	26
3.1.1	Power Supply Design Guide.....	26
3.1.2	Recommended Power Supply Circuit.....	30
3.1.3	Voltage Monitor.....	31
3.2	Power On and Off Module.....	31
3.2.1	Power On.....	31
3.2.2	Power Off.....	33
3.3	Reset Function.....	34
3.4	Output Power Management.....	36
3.5	USB Interface.....	37
3.6	PCIe Interface.....	40
3.6.1	PCIe for W80.....	42
3.6.2	PCIe for RTL8125B.....	43
3.6.3	PCIe Switch.....	44
3.7	SDIO Interface.....	45
3.8	RGMI Interface.....	47
3.9	(U)SIM Interface.....	49
3.10	I2S Interface.....	51
3.10.1	I2S Timing.....	52
3.10.2	I2S Reference Circuit.....	53
3.11	I2C Interface.....	54
3.12	UART Interface.....	55
3.13	SPI Interface.....	56
3.14	ADC Interface.....	57
3.15	WLAN/BT Interface.....	58
3.16	PM8150B Interface.....	59
3.17	GPIOs Interface.....	61
3.18	Network Status.....	62
3.19	Flight Mode Control.....	63
3.20	TDD_SYNC_PPS.....	64
3.21	Antenna Control Interface*.....	65

4	Antenna Interfaces	66
4.1	Antenna Definitions.....	66
4.1.1	3G/4G/5G Operating Frequency.....	67
4.1.2	GNSS Frequency.....	68
4.2	Antenna Installation.....	69
4.2.1	PCB Layout Guidelines.....	69
4.2.2	Antenna Tuner.....	69
4.2.3	Antenna Requirements.....	71
4.2.4	RF Plug Recommendation.....	72
5	Electrical Specifications	75
5.1	Absolute Maximum Ratings.....	75
5.2	Operating Conditions.....	75
5.3	Operating Mode.....	76
5.3.1	Operating Mode Definition.....	76
5.3.2	Sleep Mode.....	77
5.3.3	Minimum Functionality Mode and Flight Mode.....	78
5.4	Current Consumption.....	78
5.5	RF Output Power.....	81
5.6	Conducted Receive Sensitivity.....	81
5.7	Thermal Design.....	81
5.8	ESD.....	81
6	Manufacturing	83
6.1	Top and Bottom View of SIM8200G.....	83
6.2	Label Description Information.....	83
6.3	Recommended PCB Footprint.....	85
6.4	Recommended SMT Stencil.....	86
6.5	Recommended SMT Reflow Profile.....	87
6.6	Moisture Sensitivity Level (MSL).....	88
6.7	Baking Requirements.....	88
7	Packaging	89
8	Appendix	92
8.1	Coding Schemes and Maximum Net Data Rates over Air Interface.....	92
8.2	Related Documents.....	94
8.3	Terms and Abbreviations.....	95
8.4	Safety Caution.....	97

Table Index

Table 1: SIM8200G frequency bands.....	10
Table 2: Key features.....	11
Table 3: IO parameters definition.....	15
Table 4: DC parameters definition.....	15
Table 5: Pin description.....	16
Table 6: VBAT pins electronic characteristics.....	26
Table 7: Definition of VBAT and GND pins.....	28
Table 8: Recommended D1 list.....	29
Table 9: Recommended power chip list.....	30
Table 10: Recommended power chip list.....	31
Table 11: Definition of PWRKEY pin.....	32
Table 12: Power on timing and electronic characteristic.....	33
Table 13: Power off timing and electronic characteristic.....	34
Table 14: Definition of RESIN_N pin.....	35
Table 15: RESET electronic characteristics.....	35
Table 16: Output power management summary.....	36
Table 17: Definition of USB interface.....	38
Table 18: Recommended CC detector list.....	39
Table 19: Recommended SS USB switch list.....	39
Table 20: Recommended OTG 5V DC-DC and USB interface TVS list.....	40
Table 21: Definition of PCIe interface.....	42
Table 22: Recommended W80 list.....	43
Table 23: Recommended RTL8125B list.....	44
Table 24: Recommended PCIe SWITCH list.....	45
Table 25: Definition of SDIO interface.....	46
Table 26: Recommended TVS and SD card socket list.....	47
Table 27: Definition of RGMII interface.....	48
Table 28: (U)SIM electronic characteristics in 1.8V mode ((U)SIM_PWR=1.8V).....	49
Table 29: (U)SIM electronic characteristics 3.0V mode ((U)SIM_PWR=3.0V).....	49
Table 30: Definition of (U)SIM interface.....	50
Table 31: Recommended TVS and (U)SIM socket list.....	51
Table 32: I2S format.....	51
Table 33: I2S timing parameters.....	52
Table 34: The PCM interface is multiplexing with I2S interface.....	53
Table 35: Definition of I2C interface.....	54
Table 36: Definition of UART interface.....	56
Table 37: Definition of SPI interface.....	57
Table 38: Definition of ADC interface.....	57
Table 39: ADC performance parameters.....	57
Table 40: Definition of WLAN/BT interface.....	58
Table 41: Definition of PM8150B interface.....	60
Table 42: GPIO list.....	61

Table 43: Definition of NET_STATUS pin.....	62
Table 44: NET_STATUS pin status.....	63
Table 45: Definition of W_DISABLE pin.....	63
Table 46: W_DISABLE pin status.....	63
Table 47: Definition of TDD_SYNC_PPS pin.....	64
Table 48: Definition of antenna control interface through GPIOs.....	65
Table 49: Antenna port definitions.....	66
Table 50: SIM8200G operating frequencies.....	67
Table 51: NR band.....	68
Table 52: GNSS frequency.....	68
Table 53: 3G/4G/5G/GNSS antennas.....	72
Table 54: GNSS antenna (for dedicated GNSS antenna only)*.....	72
Table 55: Electrical Specifications of 20449-001E-03.....	73
Table 56: Absolute maximum ratings.....	75
Table 57: VBAT recommended operating ratings.....	75
Table 58: 1.8V digital I/O characteristics.....	76
Table 59: Operating temperature.....	76
Table 60: Operating mode definition.....	76
Table 61: Current consumption on VBAT pins (VBAT=3.8V).....	78
Table 62: Conducted output power.....	81
Table 63: The ESD performance measurement table (temperature: 25°C, humidity: 45%).....	82
Table 64: Label description of module information.....	84
Table 65: MSL ratings summary.....	88
Table 66: Baking requirements.....	88
Table 67: Tray size.....	90
Table 68: Small carton size.....	90
Table 69: Big carton size.....	91
Table 70: Coding schemes and maximum net data rates over air interface.....	92
Table 71: Related documents.....	94
Table 72: Terms and abbreviations.....	95
Table 73: Safety caution.....	97

Figure Index

Figure 1: SIM8200G module block diagram.....	11
Figure 2: Pin assignment.....	14
Figure 3: Dimensions of SIM8200G (unit: mm).....	25
Figure 4: Power consumption at ENDC combination of B3 (20MHz) and N79 (100MHz).....	27
Figure 5: Power consumption of entire system.....	27
Figure 6: Power supply reference circuit.....	28
Figure 7: Linear regulator reference circuit.....	30
Figure 8: Switching mode power supply reference circuit.....	30
Figure 9: Power on the module use button.....	32
Figure 10: Power on the module use GPIO drive.....	32
Figure 11: Power on sequence.....	33
Figure 12: Power off sequence.....	34
Figure 13: Reset the module use GPIO drive.....	35
Figure 14: Reset the module use button.....	35
Figure 15: The reset timing sequence of the module.....	36
Figure 16: Type-C USB reference circuit with PM8150B.....	37
Figure 17: Type-C USB reference circuit with CC detector.....	38
Figure 18: USB3.1 reference circuit.....	38
Figure 19: PCIe interface reference circuit (RC).....	41
Figure 20: PCIe interface reference circuit (EP).....	41
Figure 21: PCIe interface reference circuit (RC) for W80.....	43
Figure 22: PCIe interface reference circuit (RC) for RTL8125B.....	44
Figure 23: PCIe switch reference circuit.....	45
Figure 24: SD card reference circuit.....	46
Figure 25: eMMC reference circuit.....	46
Figure 26: RGMII to RJ45 diagram circuit.....	48
Figure 27: (U)SIM interface reference circuit.....	50
Figure 28: I2S timing.....	52
Figure 29: Audio codec reference circuit.....	53
Figure 30: I2C reference circuit.....	54
Figure 31: UART level conversion circuit.....	55
Figure 32: UART TX level conversion circuit.....	55
Figure 33: UART RX level conversion circuit.....	55
Figure 34: SPI reference circuit.....	57
Figure 35: SIM8200G and W80 connect circuit.....	58
Figure 36: PM8150B interface diagram circuit.....	60
Figure 37: NET_STATUS reference circuit.....	62
Figure 38: W_DISABLE pin reference circuit.....	63
Figure 39: TDD_SYNC_PPS pin reference circuit.....	64
Figure 40: Aperture tuner reference block diagram.....	70
Figure 41: Impedance tuner reference block diagram.....	70
Figure 42: Hybrid tuner reference block diagram.....	70

Figure 43: M.2 package Tuner mipi interface.....	71
Figure 44: LGA package Tuner mipi interface.....	71
Figure 45: 3D view of 20449-001E-03.....	73
Figure 46: 3D view of 20449-001E-03.....	74
Figure 47: Top and bottom view of SIM8200G.....	83
Figure 48: Label description of module.....	83
Figure 49: Recommended PCB footprint.....	85
Figure 50: Recommended SMT stencil.....	86
Figure 51: Recommended SMT reflow profile.....	87
Figure 52: Packaging process.....	89
Figure 53: Module tray drawing.....	89
Figure 54: Small carton drawing.....	90
Figure 55: Big carton drawing.....	91

SIMCom
Confidential

1 Introduction

This document describes the electronic specifications, RF specifications, interfaces, mechanical characteristics and test results of the SIM8200G module. With the help of this document, customers can quickly understand SIM8200G module.

Associated with other software application notes and user guides, customers can use SIM8200G to design and develop mobile and laptop applications easily.

1.1 Product Outline

SIM8200G is a wireless communication module focusing on 5G market; it supports multi-air access technology including 5G NR (NSA/SA), LTE-FDD, LTE-TDD, and WCDMA, can meet the 3GPP R15 NR specification, and also integrates GNSS¹ system including dual bands GPS, GLONASS, Beidou, Galileo and QZSS.

The module's supported radio frequency bands are shown in the following table.

Table 1: SIM8200G frequency bands

Standard	Frequency bands
5G NR	n1/n2/n3/n5/n7/n8/n12/n20/n28/n38/n40/n41/n48/n66/n71/n77/n78/n79
LTE-FDD	B1/B2/B3/B4/B5/B7/B8/B12/B13/B14/B17/B18/B19/B20/B25/B26/B28/B29/B30/B32/B66/B71
LTE-TDD	B34/B38/B39/B40/B41/B42/B43/B48
WCDMA	B1/B2/B3/B4/B5/B8
GNSS ¹	GPS L1+L5 dual bands/GLONASS/BeiDou/Galileo/QZSS

NOTE

1. GNSS function is optional.

With a physical dimension of 41.0mm*43.6mm*2.8mm, SIM8200G can meet almost all requirements of customer's applications.

With the 369 LGA pins, SIM8200G owns rich interfaces, includes USB3.1, PCIe3.0, SDIO3.0, RGMII2.0, (U)SIM card, digital audio(I2S or PCM), SPI, I2C, UART, GPIOs, eight antennas for 3G/4G/5G and GNSS.

With all these interfaces, SIM8200G can also be utilized in the handheld terminal, machine-to-machine laptop application and especially the 5G CPE.

1.2 Hardware Block Diagram

The block diagram of SIM8200G is shown in the following figure.

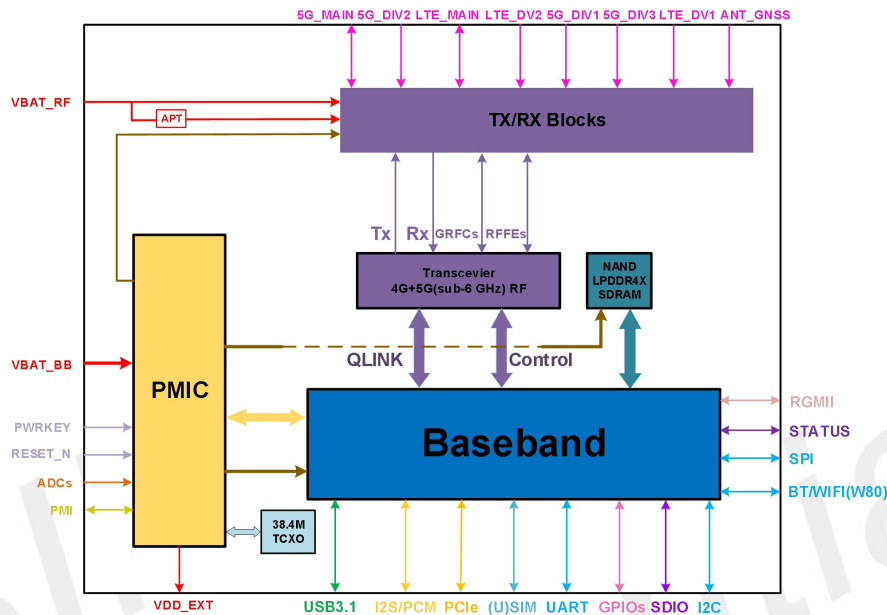

Figure 1: SIM8200G module block diagram

1.3 Feature Overview

Table 2: Key features

Feature	Implementation
Application processor	Arm Cortex-A7 up to 1.5 GHz
Memory RAM	4Gb 16-bit LPDDR4X at 1.8 GHz
Memory ROM	4Gb 8-bit NAND
Power supply	VBAT:3.3V~4.4V Typical: 3.8V
Power consumption	Typical: 3mA @sleep mode(GNSS off ,VBAT=3.8V)
Transmit power	Power Class 3 for WCDMA/LTE/5G NR Power Class 2 for 5G NR(n41/n77/n78/n79)
Data transmission throughput	2.4Gbps (DL)/1Gbps(UL) (optional up to 4Gbps DL) for NR 1Gbps (DL)/200Mbps(UL) (optional up to 2Gbps DL) for LTE 42 Mbps(DL)/5.76Mbps(UL) for HSPA+
Antenna	Eight antennas for 3G/4G/5G and GNSS
GNSS(optional)	GNSS engine: GPS L1+L5/GLONASS/BeiDou/Galileo/QZSS Protocol: NMEA

SMS	<p>MT, MO, CB, Text and PDU mode</p> <p>SMS storage: (U)SIM card or ME(default)</p> <p>Transmission of SMS alternatively over CS or PS.</p>
(U)SIM interface	<p>Support identity card: 1.8V/ 3.0V</p> <p>Include (U)SIM1 and (U)SIM2 interfaces</p> <p>Support Dual SIM single standby</p>
(U)SIM application toolkit	<p>Support SAT class 3</p> <p>Support USAT</p>
Phonebook management	<p>Support phonebook types: DC,MC,RC,SM,ME,FD,ON,LD,EN</p>
Digital audio interface	<p>One I2S interface with dedicated main-clock for primary digital audio, the I2S also can be configured as PCM</p> <ul style="list-style-type: none"> ● MCLK frequency: 12.288MHz (default) ● WCDMA AMR-NB ● VoLTE AMR-WB ● Echo cancellation ● Noise suppression
PCIe interface	<ul style="list-style-type: none"> ● Two lane PCIe interfaces, support PCIe Gen 3 (Gen 1/2 compatible) ● High communication data rate which up to 8Gbps per lane.
WLAN/BT interface	<p>Support W80² interface, which support 802.11ax with 1.775Gbps</p> <p>WL_I2S cannot be used for W80 module.</p>
RGMII interface	<ul style="list-style-type: none"> ● Integrated RGMII MAC for Ethernet ● Data rate up to 1000Mbps
PMI interface ³	<p>Support PM8150B interface, which support USB Type-C and QC4.0*</p>
UART interface	<ul style="list-style-type: none"> ● Support up to three UART ● Data rate up to 4 Mbps
I2C interface	<ul style="list-style-type: none"> ● Support up to two I2C, meet I2C specification, version 5.0 ● Data rate up to 400 Kbps
SPI interface	<ul style="list-style-type: none"> ● Only support master mode ● Data rate up to 50Mbps
SDIO interface	<ul style="list-style-type: none"> ● Support 4bit SD card or 8bit eMMC, meet SDIO3.0 specification ● 1.8V or 3.0V dual-voltage operation for SD card ● Data rate up to 100Mbps
USB interface	<p>Support one USB controller, USB3.1 Gen2 or USB2.0</p> <p>USB3.1: super speed, with data rate which up to 10Gbps</p> <p>USB2.0: high speed interface, support USB operations at low-speed and full-speed, which refer to USB1.0 and USB1.1</p>
Firmware upgrade	<p>Firmware upgrade over USB interface</p>
Physical characteristics	<p>Size: 41mm*43.6mm*2.8mm</p> <p>Weight: 11.17g</p>
Temperature range	<p>Normal operation temperature: -30°C to +70°C 3GPP compliant</p> <p>Extended operation temperature: -40°C to +85°C⁴</p> <p>Storage temperature: -40°C to +90°C</p>

NOTE

1. "*" means under development.
2. W80 is SIMCom WiFi-6 module.
3. Standard software not support PM8150B function.
4. Module is able to establish and maintain voice, data transmission, SMS and emergency call, etc.
The performance may deviate slightly from the 3GPP specifications and will meet 3GPP specifications again when the temperature returns to normal operating temperature levels.

SIMCom
Confidential

2 Package Information

2.1 Pin Assignment Overview

All functions of the SIM8200G will be provided through 369 LGA pins that will be connected to the customer's platform. The following figure is a high-level view of the pin assignment of the module.

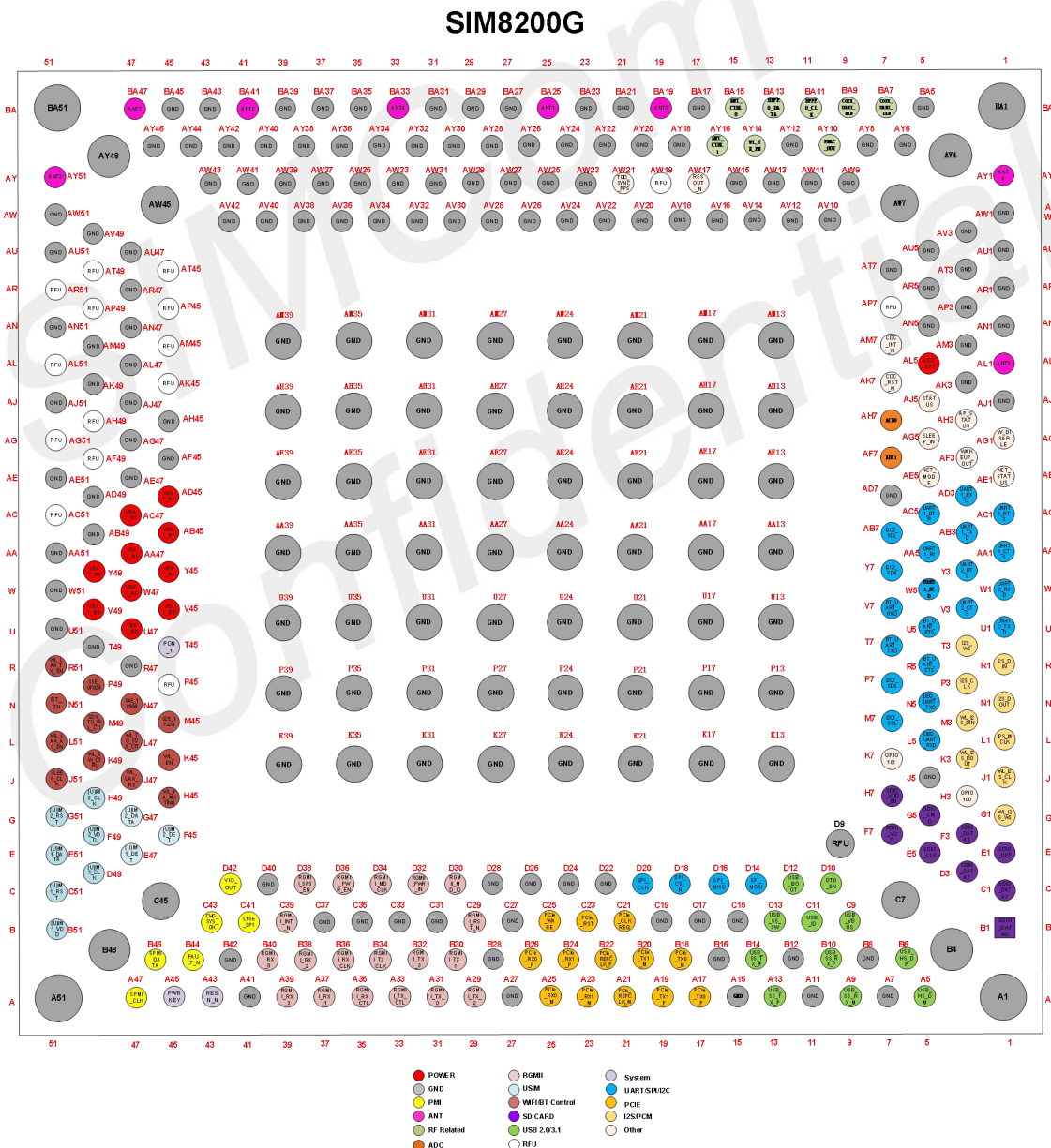

Figure 2: Pin assignment

2.2 Pin Description

Table 3: IO parameters definition

Pin type	Description
PI	Power Input
PO	Power Output
AI	Analog Input
AIO	Analog Input /Output
DIO	Bidirectional Digital Input /Output
DI	Digital Input
DO	Digital Output
PU	Pull Up
PD	Pull Down

Table 4: DC parameters definition

Voltage domain	Parameter	Min	Typ	Max	
P2	VDD_P2=1.8V				
	V _{OH}	High level output	1.4V	-	-
	V _{OL}	Low level output	0V	-	0.45V
	V _{IH}	High level input	1.27V	-	2V
	V _{IL}	Low level input	0V	-	0.58V
	R _p	Pull up/down resistor	10K ohm	-	100K ohm
	VDD_P2=3.0V				
	V _{OH}	High level output	2.25V	-	3.0V
	V _{OL}	Low level output	0V	-	0.375V
	V _{IH}	High level input	1.84V	-	3.25V
	V _{IL}	Low level input	0V	-	0.75V
R _p	Pull up/down resistor	10K ohm	-	100K ohm	
P3	VDD_P3=1.8V				
	V _{OH}	High level output	1.35V	-	1.8V
	V _{OL}	Low level output	0V	-	0.45V
	V _{IH}	High level input	1.26V	-	2.1V
	V _{IL}	Low level input	0V	-	0.6V
R _p	Pull up/down resistor	20K ohm	-	60K ohm	
P4/P5	VDD_P4/P5=1.8V				

	V _{OH}	High level output	1.44V	-	1.8V
	V _{OL}	Low level output	0V	-	0.4V
	V _{IH}	High level input	1.26V	-	2.1V
	V _{IL}	Low level input	0V	-	0.36V
	R _p	Pull up/down resistor	10K ohm	-	100K ohm
	VDD_P4/P5=3.0V				
	V _{OH}	High level output	2.4V	-	3.0V
	V _{OL}	Low level output	0V	-	0.4V
	V _{IH}	High level input	2.1V	-	3.05V
	V _{IL}	Low level input	0V	-	0.6V
	R _p	Pull up/down resistor	10K ohm	-	100K ohm
P8	VDD_P8=1.8/2.5V				
	R _p	Pull up/down resistor	20K ohm	-	50K ohm

Table 5: Pin description

Pin name	Pin no.	Electrical description	Description	Comment
Power supply				
VBAT_BB	V45, V49, U47	PI V _{MAX} =4.4V V _{TYP} =3.8V V _{MIN} =3.3V	Input power supply for module's BB part	
VBAT_RF	Y49, AC47,A A47,W4 7, AD45,A B45,Y4 5	PI V _{MAX} =4.4V V _{TYP} =3.8V V _{MIN} =3.3V	Input power supply for module's RF part	
VDD_EXT	AL5	PO V _{TYP} =1.8V	Output power supply for external IO pull up circuits	
S2E_1P224	M45	PO V _{TYP} =1.28V	Output power supply for W80 only	
S3E_0P824	P49	PO V _{TYP} =0.88V	Output power supply for W80 only	
S4E_1P904	N47	PO V _{TYP} =1.88V	Output power supply for W80 only	
L10E_3P1	C41	PO V _{TYP} =3.08V	Output power supply for PM8150B USB PD-PHY and USB switch	
VIO_OUT	D42	PO V _{TYP} =1.8V	Output power supply for PM8150B IO circuit only	

GND	A7,B8,A11,B12,C15,A15,B16,C17,C19,D22,D24,D26,C27,A27,B28,D28,C31,C33,C35,C37,D40,A41,B42,J5,AD7,AJ1,AK3,AM3,AN1,AN5,AP3,AR1,AR5,AT3,AT7,AU1,AU5,AV3,AW1,R47,T49,U51,W51,AA51,AB49,AD49,AE47,AF45,AH45,AG47,AJ47,AL47,AN47,AR47,AU47,AV49,AW51,AV10,AV12,AV14,AV16,AV18,AV20,AV22,AV24,AV26,AV28,AV30,AV32,AV34,AV36,AV38,AV40,AV42,AW9,AW11,AW13,AW15,AW23,AW25,AW27,AW29,AW31,AW33,AW35,AW37,AW39,AW41,AW43,AY6,AY8,AY12,AY18,AY20,AY22,AY24,AY26,AY28,AY30,AY32,AY34,AY36,AY38,AY40,AY42,AY44,AY46,BA5,BA17,BA21,BA23,BA27,BA29,BA31,BA35,BA39,BA43,BA45,AM13,AM17,AM21,AM24,AM27,AM31,AM35,AM39,AH13,AH17,AH21,AH24,AH27,AH31,AH35,AH39,AE13,AE17,AE21,AE24,AE27,AE31,AE35,AE39,AA13,AA17,AA21,AA24,AA27,AA31,AA35,AA39,U13,U17,U21,U24,U27,U31,U35,U39,P13,P17,P21,P24,P27,P31,P35,P39,K13,K17,K21,K24,K27,K31,K35,K39,A1,B4,C7,A51,B48,C45,BA1,AY4,AW7,BA51,AY48,AW45,AU51,AN51,AE51,AM49,AK49,AJ51,AE51,BA37				Ground
-----	---	--	--	--	--------

System control

PWRKEY ²	A45	DI	1.1V	Power on/off the module, active low	Pull up to 1.1V internally without PM8150B
PON_1	T45	DI	1.8V	Power on the module, active high	
RESIN_N	A43	DI	P3	Reset the module, active low	
TDD_SYNC_PPS	AW21	DO	P3	1. It can generate pulse use for indication NSA and SA sub6 the beginning frame flag of DL-UL 2. The TDD_SYNC_PPS pin also can be configured GPS_1PPS signal output by software	1.8V voltage domain. S2-109WT supports this function The TDD_SYNC_PPS and GPS_1PPS function can't be used at the same time.

Status indicator

STATUS	AJ5	DO	P3	Indicate operation status of the module	
AP_STATUS*	AH3	DI	P3	Indicate operation status of the AP	Standard software not support this function
NET_MODE*	AE5	DO	P3	Indicate network registration mode of the module	
NET_STATUS	AE1	DO	P3	Indicate network activity status of the module	

USB interface

USB_VBUS	C9	AI		USB VBUS detection	Not support charge
----------	----	----	--	--------------------	--------------------

USB_HS_DP	B6	AI O		Differential USB bi-directional data plus	Required 90Ω differential impedance
USB_HS_DM	A5	AI O		Differential USB bi-directional data minus	Compliant with USB 2.0 standard specifications
USB_SS_TX_P	A13	AO		USB3.1 super-speed transmit data plus	Required 90Ω differential Impedance
USB_SS_TX_M	B14	AO		USB3.1 super-speed transmit data minus	
USB_SS_RX_P	B10	AI		USB3.1 super-speed receive data plus	Compliant with USB 3.1 standard specifications
USB_SS_RX_M	A9	AI		USB3.1 super-speed receive data minus	
USB_ID*	C11	DI	P3	USB ID	Standard software not support this function
OTG_EN*	D10	DO	P3	USB OTG power supply DC-DC enable signal	Standard software not support this function
USB_SS_SW	C13	DO	P3	USB Type-C switch control signal	

(U)SIM interface

(U)SIM1_VDD	B51	PO		Power supply for (U)SIM1 card	1.8/3.0V voltage domain, (U)SIM interface should be protected against ESD. If unused, please keep open
(U)SIM1_DATA	E51	DI O	P4	(U)SIM1 card data signal, which has been pulled up to (U)SIM1_VDD by a 20K resistor internally	
(U)SIM1_CLK	D49	DO	P4	(U)SIM1 clock signal	
(U)SIM1_RST	C51	DO	P4	(U)SIM1 reset signal	
(U)SIM1_DET	E47	DI	P3	(U)SIM1 card detect signal, which need pulled up to VDD_EXT by a 470K resistor externally	
(U)SIM2_VDD	F49	PO		Power supply for (U)SIM2 card	
(U)SIM2_DATA	G47	DI O	P5	(U)SIM2 card data, which has been pulled up to (U)SIM2_VDD by a 20K resistor internally	
(U)SIM2_CLK	H49	DO	P5	(U)SIM2 clock signal	
(U)SIM2_RST	G51	DO	P5	(U)SIM2 reset signal	
(U)SIM2_DET	F45	DI	P3	(U)SIM2 card detect, which need pulled up to VDD_EXT by a 470KR resistor externally	

SPI interface

SPI_CS_N	D18	DO	P3	SPI chip select	
SPI_CLK	D20	DO	P3	SPI clock	
SPI_MOSI	D14	DO	P3	Master output slaver input	
SPI_MISO	D16	DI	P3	Master input slaver output	
UART1 interface					
UART1_CTS	AA1	DI	P3	Clear to send	
UART1_RTS	AC1	DO	P3	Request to send	Default use for AT command
UART1_TXD	AB3	DO	P3	Transmit data	
UART1_RXD	AD3	DI	P3	Receive data	
UART1_DCD	W5	DO	P3	Carrier detect	
UART1_RI	AA5	DO	P3	Ring indicator	
UART1_DTR	AC5	DI	P3	Data terminal ready	
UART2 interface					
UART2_CTS	V3	DI	P3	Clear to send	UART2 and BT_UART cannot be used at the same time
UART2_RTS	Y3	DO	P3	Request to send	
UART2_TXD	U1	DO	P3	Transmit data	
UART2_RXD	W1	DI	P3	Receive data	
BT UART interface					
BT_UART_CTS	R5	DI	P3	Clear to send	Default use for BT
BT_UART_RTS	U5	DO	P3	Request to send	
BT_UART_TXD	T7	DO	P3	Transmit data	
BT_UART_RXD	V7	DI	P3	Receive data	
Debug UART interface					
DBG_UART_RXD	L5	DI	P3	Receive data	Used for debug only
DBG_UART_TXD	N5	DO	P3	Transmit data	
I2C interface³					
I2C1_SCL	M7	OD	P3	I2C1 clock signal	I2C1 default use for codec Pull up to VDD_EXT externally
I2C1_SDA	P7	OD	P3	I2C1 data signal	
I2C2_SCL	AB7	OD	P3	I2C2 clock signal	I2C2 default use for sensor Pull up to VDD_EXT externally
I2C2_SDA	Y7	OD	P3	I2C2 data signal	
WLAN I2S interface					
WL_I2S_DOUT	K3	DO	P3	WLAN I2S data output	This group signals of the module cannot connect W80 module, please keep open
WL_I2S_DIN	M3	DI	P3	WLAN I2S data input	
WL_I2S_CLK	J1	DO	P3	WLAN I2S bit clock	
WL_I2S_WS	G1	DO	P3	WLAN I2S word select	
I2S(PCM) interface					

I2S_DOUT/ PCM_DOUT	N1	DO	P3	I2S/PCM data output	Default is I2S interface, can be configured as PCM interface by software, If unused, please keep open
I2S_DIN/ PCM_DIN	R1	DI	P3	I2S/PCM data input	
I2S_CLK/ PCM_CLK	P3	DO	P3	I2S/PCM clock output	
I2S_WS/ PCM_SYNC	T3	DI O	P3	I2S word select/ PCM synchronous signal	
I2S_MCLK	L1	DO	P3	I2S master clock output	
ADC interface					
ADC0	AH7	AI		Analog to digital converter input0	
ADC1	AF7	AI		Analog to digital converter input1	
RGMI interface⁴					
RGMI_MD_IO	D30	DI O	P8	RGMI management data	Required 50Ω impedance
RGMI_MD_CLK	D34	DO	P8	RGMI management data clock	
RGMI_RX_CTL	A35	DI	P8	RGMI receive control	
RGMI_RX_CLK	B36	DI	P8	RGMI receive clock	
RGMI_RX_0	B40	DI	P8	RGMI receive data bit 0	
RGMI_RX_1	A37	DI	P8	RGMI receive data bit 1	
RGMI_RX_2	B38	DI	P8	RGMI receive data bit 2	
RGMI_RX_3	A39	DI	P8	RGMI receive data bit 3	
RGMI_TX_CTL	A33	DO	P8	RGMI transmit control	
RGMI_TX_CLK	B34	DO	P8	RGMI transmit clock	
RGMI_TX_0	A31	DO	P8	RGMI transmit data bit 0	
RGMI_TX_1	B30	DO	P8	RGMI transmit data bit 1	
RGMI_TX_2	A29	DO	P8	RGMI transmit data bit 2	
RGMI_TX_3	B32	DO	P8	RGMI transmit data bit 3	
RGMI_INT_N	C39	DI	P3	Interrupt input from RGMI PHY	
RGMI_RST_N	C29	DO	P3	Reset output to RGMI PHY	
RGMI_PWR_EN	D36	DO	P3	Used to enable external LDO to supply 1.8V power to RGMI_PWR_IN	
RGMI_PWR_IN	D32	PI	1.8V	Power supply input for internal RGMI circuit	
RGMI_3P3_EN	D38	DO	P3	Used to enable external DC-DC/LDO to supply 3.3V	

				power to RGMII PHY	
PCIe interface⁵					
PCIe_REFCLK_P	B22	AI		PCIe reference clock plus	
PCIe_REFCLK_M	A21	AI		PCIe reference clock minus	
PCIe_TX0_M	B18	AO		PCIe transmit0 minus	Required 90Ω differential impedance
PCIe_TX0_P	A17	AO		PCIe transmit0 plus	
PCIe_TX1_M	B20	AO		PCIe transmit1 minus	
PCIe_TX1_P	A19	AO		PCIe transmit1 plus	
PCIe_RX0_M	A25	AI		PCIe receive0 minus	
PCIe_RX0_P	B26	AI		PCIe receive0 plus	
PCIe_RX1_M	A23	AI		PCIe receive1 minus	
PCIe_RX1_P	B24	AI		PCIe receive1 plus	
PCIe_CLKREQ	C21	DI	P3	PCIe clock request	CLKREQ and WAKE need pull up to VDD_EXT externally, Default as RC mode
PCIe_WAKE	C25	DI	P3	PCIe wake-up	
PCIe_RST	C23	DO	P3	PCIe reset	
W80 interface					
WL_SW_CTRL	K49	DO	P3	W80 switch control	
SDX_TO_WL_CTI	M49	DO	P3	W80 GPIO	
WL_TO_SDX_CTI	L47	DI	P3	W80 GPIO	Before powering on the module, please keep this pin floating.
BT_EN	N51	DO	P3	W80 BT enable	
SLEEP_CLK	J51	DO		Sleep clock output for W80 only	
WL_EN	K45	DO	P3	WLAN enable	
WL_LAA_RX	J47	DI	P3	WLAN XFEM control for LAA receiver	
WL_PA_MUTING	H45	DO	P3	WLAN XFEM control for PA mute	
WL_LAA_AS_EN	L51	DO	P3	WLAN LAA AS enable	
WL_LAA_TX_EN	R51	DO	P3	WLAN XFEM control for LAA enable	W80 RF coexistence signals
COEX_UART_TXD	BA7	DO	P3	LTE&WLAN coexistence data transmit	
COEX_UART_RXD	BA9	DI	P3	LTE&WLAN coexistence data receive	
WL_TX_EN	AY14	DI	P3	WLAN XFEM control for WLAN TX enable	

SDIO interface

SDIO_VDD	F7	PI	1.8/3.0V	Power input for internal SDIO circuit	
SDIO_DATA0	B1	DI O	P2	SDC data bit 0 or eMMC* data bit 0	Required 50Ω impedance
SDIO_DATA1	C1	DI O	P2	SDC data bit 1 or eMMC data bit 1	
SDIO_DATA2	D3	DI O	P2	SDC data bit 2 or eMMC data bit 2	
SDIO_DATA3	F3	DI O	P2	SDC data bit 3 or eMMC data bit 3	
SDIO_CMD	G5	DI O	P2	SDC command output	
SDIO_CLK	E5	DO	P2	SDC clock output	
SDIO_VDD_EN	H7	DO	P3	Enable the SD card power or eMMC data bit 4	
SDIO_DET	E1	DI	P3	SD card insertion detect or eMMC data bit 5	If used as eMMC data signals, required 50Ω impedance.
GPIO100	H3	DI O	P3	eMMC data bit 6	
GPIO101	K7	DI O	P3	eMMC data bit 7	
RESOUT_N	AW17	DO	P3	eMMC RST_N	Module SN: S2-109WT supports this function
PM8150B interface					
CHG_SYS_OK	C43	DI		When charger input is inserted PM8150B output signal to PMU	Used for PM8150B only
FAULT_N	B44	DI O		Used to send/receive the fault condition across all PMICs in the chipset	Standard software not support PM8150B function
SPMI_CLK	A47	DO		SPMI communication bus clock signal	Required 50Ω impedance
SPMI_DATA	B46	DI O		SPMI communication bus data signal	
Other interface					
EMAC_OUT*	AY10	DO	P3	1PPS time sync output	
USB_BOOT	D12	DI	P3	Module will be forced into USB boot mode by connect this pin to VDD_EXT externally	
W_DISABLE	AG1	DI	P3	Flight mode control input active low	
SLEEP_IN*	AG5	DI	P3	Sleep mode control input	Standard software not support this function
WAKEUP_OUT	AF3	DO	P3	Module wake up the external	Standard software

*				AP	not support this function
CDC_RST_N*	AK7	DO	P3	Module reset the external CODEC active low	Standard software not support this function
CDC_INT_N*	AM7	DI	P3	External CODEC interrupt input active low	Standard software not support this function
Antenna control interface⁶					
RFFE0_CLK	BA11	DO	P3	Antenna tuner MIPI CLK	Refer to 4.2.2 Antenna tuner
RFFE0_DATA	BA13	DI O	P3	Antenna tuner MIPI DATA	Refer to 4.2.2 Antenna tuner
ANT_CTRL0	BA15	DO	P3	Antenna tuner control0	Refer to 4.2.2 Antenna tuner
ANT_CTRL1	AY16	DO	P3	Antenna tuner control1	Refer to 4.2.2 Antenna tuner
Antenna interface					
ANT0	AL1	AI O		LTE low/middle/high BAND signal send and receive; n41 signal send and receive; n79 signal diversity receive	617MHz~960MHz 1710MHz~2690MHz 4400MHz~5000MHz
ANT1	BA25	AI		LTE middle/high band signal diversity receive; n41&n77 signal diversity receive	1710MHz~2690MHz 3300MHz~4200MHz
ANT2	BA41	AI O		LTE low/middle/high band signal diversity receive; N79 signal send and receive N41 signal diversity receive	617MHz~960MHz 1710MHz~2690MHz 4400MHz~5000MHz
ANT3	AY51	AI O		LTE middle/high BAND signal diversity receive; n77 signal diversity receive	1710MHz~2690MHz 3300MHz~4200MHz
ANT4	BA33	AI O		n41 signal send and receive; n77 signal send and receive	2496MHz~2690MHz 3300MHz~4200MHz
ANT5	BA19	AI O		n77 signal send and receive	3300MHz~4200MHz
ANT6	AY1	AI		n79 signal diversity receive; GNSS signal receive ;	1166MHz~1229MHz 1565MHz~1610MHz 4400MHz~5000MHz
ANT7	BA47	AI O		n79 signal send and receive	4400MHz~5000MHz
RFU interface					
RFU	AP7,AW19,AT45,AP45,AM45,AK45,AG51,AR51,AL51,AC51,AT49,AP49,AH49,AF49,P45,			Reserved for future use	

NOTE

1. “*” means under development.
2. PWRKEY will be pulled up to 1.8V internally if used PM8150B.
3. The I2C signals need pull up to VDD_EXT by 2.2K resistors out of the module.
4. If not use RGMII function, the RGMII_PWR_IN pin should connect to VDD_EXT out of the module.
5. If not use SDIO function, the SDIO_VDD pin should connect to VDD_EXT out of the module.
6. Please confirm with SIMCom support teams for the details design about antenna control interface.
7. Only used to W80 and PM8150B pins don't use as other circuits.
8. WL_I2S cannot be used for W80 module.
9. Unused and RFU pins should keep open.
10. Recommend ESD protect components out of the module for used interfaces.
11. The GPIO MAX voltage is 2.1V, if exceeded, may cause permanent damage to the module.
12. All GND pins should be connected to the customer's main PCB.

SIMCOM
Confidential

2.3 Mechanical Dimensions

The following figure shows the mechanical dimensions of SIM8200G.

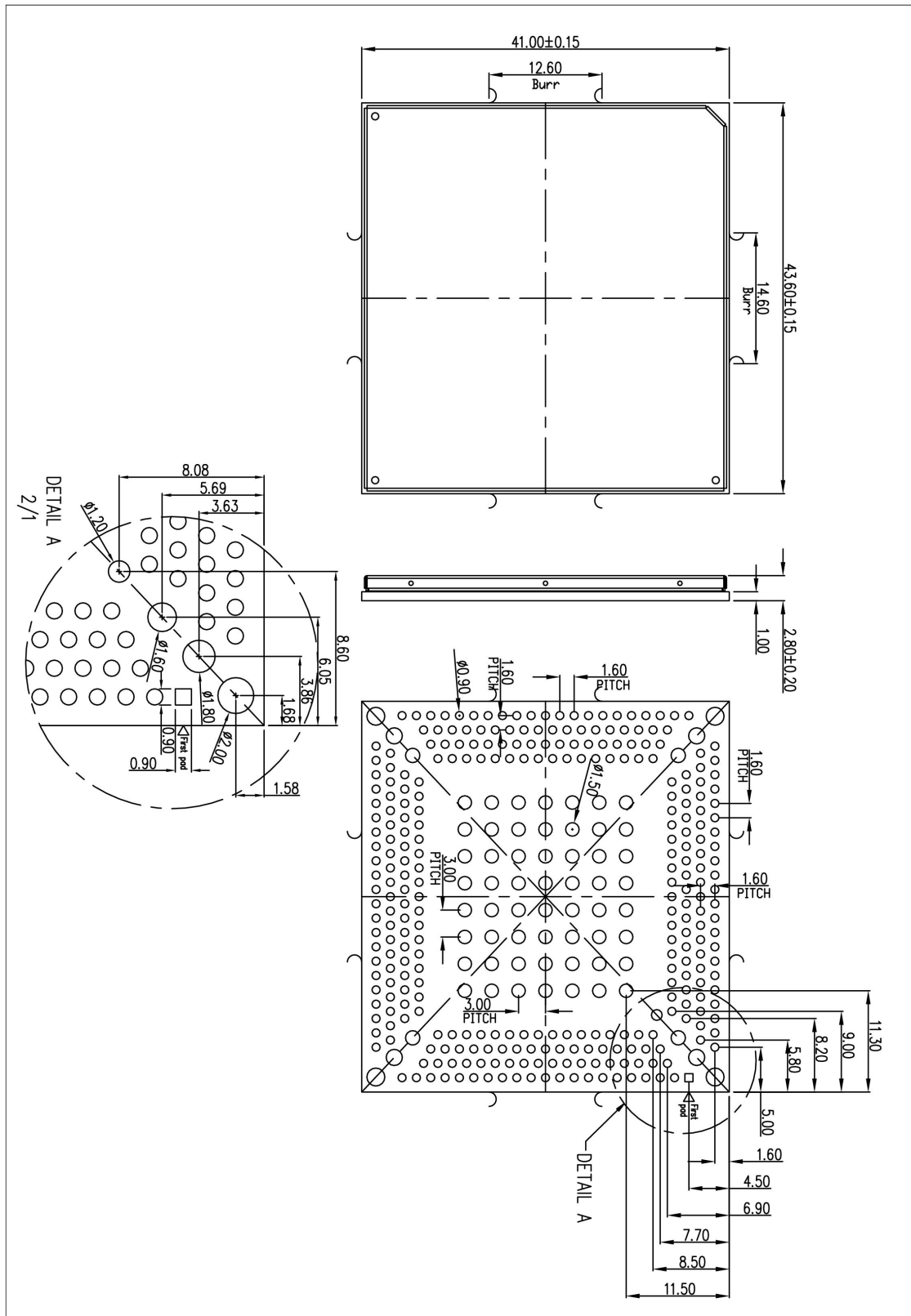

Figure 3: Dimensions of SIM8200G (unit: mm)

3 Interface Application

3.1 Power Supply

The recommended power supply for SIM8200G is 3.8V and the voltage range is 3.3V to 4.4V. Please ensure that the input voltage is never lower than 3.3V, otherwise the module will be powered off automatically. The module has 3 BB power pins, 7 RF power pins and 10 power ground pins, to ensure the module works normally, all power and ground pins should be connected.

Table 6: VBAT pins electronic characteristics

Symbol	Description	Min.	Typ.	Max.	Unit
VBAT ¹	Module power supply voltage	3.3	3.8	4.4	V
I _{peak} ²	Peak current	-	-	1.6	A
I _{sleep} ²	Current in sleep mode	-	3	-	mA
I _{leakage} ²	Current in power off mode	-	28	-	uA

NOTE

1. The VBAT include VBAT_BB and VBAT_RF pins in this document.
2. Total current of the whole module.

3.1.1 Power Supply Design Guide

When B3(20MHz) and N79(100MHz) ENDC combination are connected under the instrument, the peak current can reach to 1.6A at 3.8V power supply. In order to ensure that the VBAT voltage is no less than required 3.3V when the module at maximum power radio transmission, and considering the voltage drop and conversion efficiency, it is strongly recommend that the DC-DC or LDO output capacity should not be less than 3A.

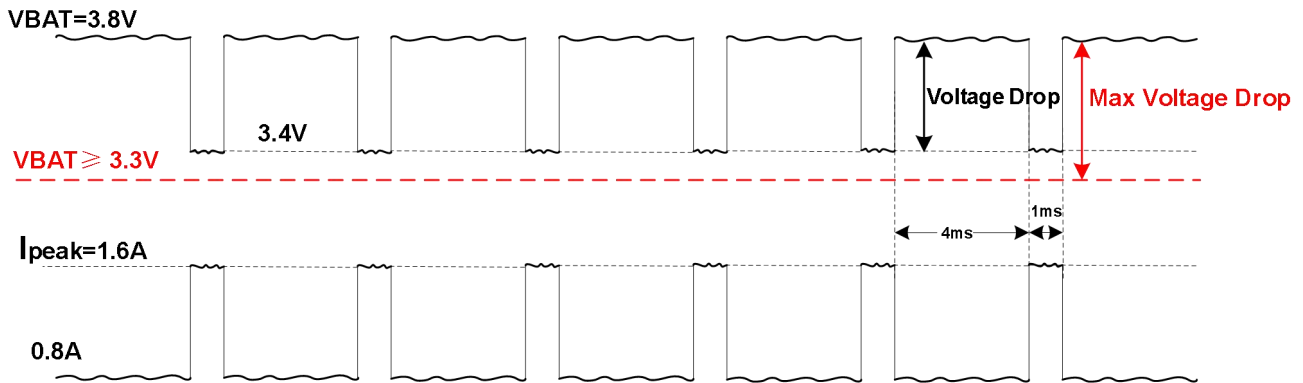

Figure 4: Power consumption at ENDC combination of B3 (20MHz) and N79 (100MHz)

NOTE

Test conditions

1. The total capacitors of VBAT net are not less than 640uF.
2. The peak current is only the current consumption of the module, don't include the current consumption of other devices outside the module.
3. The I_{peak} and voltage drop data in Table 6 and Figure 4 were tested using SIMCom EVB and connecting instrument at 3.8V power supply, the ENDC combination is B3(20MHz) and N79(100MHz), subcarrier spacing is 30KHz.
4. The B3(20MHz) and N79(100MHz) ENDC combination is the max power consumption of the module.
5. When the voltage drop on VBAT reaches its maximum value, please ensure that its minimum voltage is not less than 3.3V.

When WLAN and ethernet functions are added according to SIMCOM's reference design, the peak current of the entire system can reach 2.6A. In order to ensure the normal operation of the module and peripherals, it is strongly recommended that the DC-DC or LDO output capacity is not less than 4A.

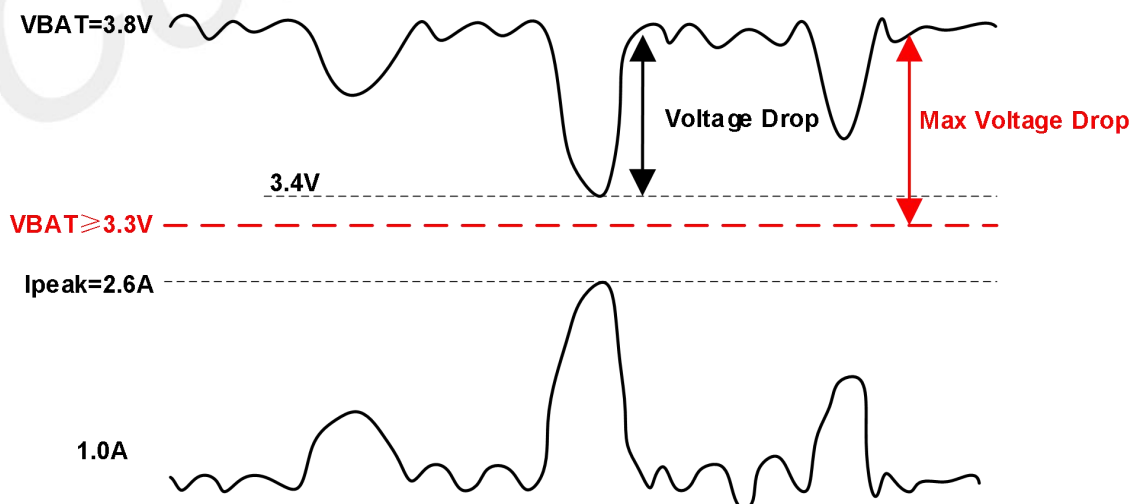

Figure 5: Power consumption of entire system

NOTE

Test conditions

1. The above current consumption data is measured using SIMCOM EVB.
2. The test current consumption data includes SIM8200G module, SIMCom WLAN module W80 and Ethernet PHY AR8035.

To decrease the voltage dropping, make sure that the capacitors of VBAT net must not less than 640uF. The following figure shows the reference circuit of power supply for the VBAT.

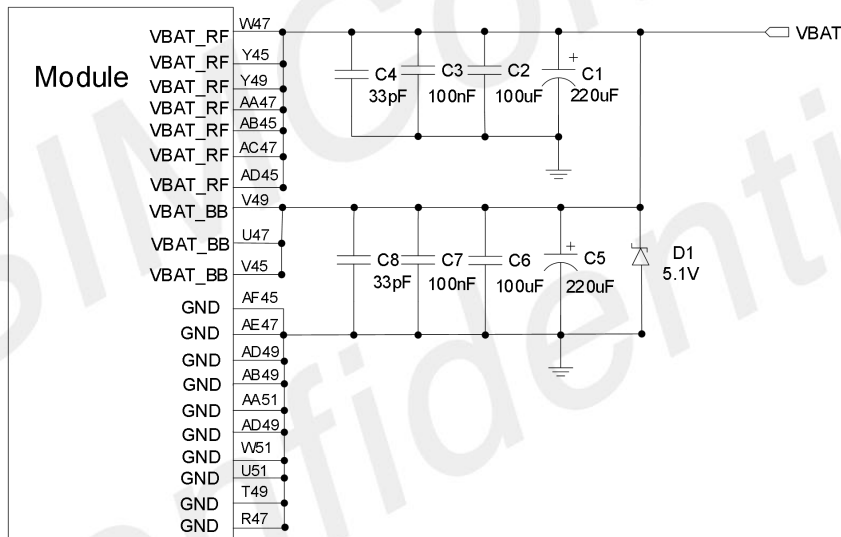

Figure 6: Power supply reference circuit

Table 7: Definition of VBAT and GND pins

Pin name	Pin no.	Electrical description	Description	Comment
VBAT_BB	V45, V49, U47	PI	$V_{MAX}=4.4V$ $V_{TYP}=3.8V$ $V_{MIN}=3.3V$	Input power supply for module's BB part
VBAT_RF	Y49, AC47,AA47, ,W47, AD45,AB45, ,Y45	PI	$V_{MAX}=4.4V$ $V_{TYP}=3.8V$ $V_{MIN}=3.3V$	Input power supply for module's RF part
GND	A7,B8,A11,B12,C15,A15,B16,C17,C19,D22,D24,D26,C27,A27,B28,D28,C31,C33,C35,C37,D40,A41,B42,J5,AD7,AJ1,AK3,AM3,AN1,AN5,AP3,AR1,AR5,AT3,AT7,AU1,AU5,AV3,A			Ground

W1,R47,T49,U51,W51,AA51,AB49,AD49,AE47,AF45,AH45,AG47,AJ47,AL47,AN47,AR47,AU47,AV49,AW51,AV10,AV12,AV14,AV16,AV18,AV20,AV22,AV24,AV26,AV28,AV30,AV32,AV34,AV36,AV38,AV40,AV42,AW9,AW11,AW13,AW15,AW23,AW25,AW27,AW29,AW31,AW33,AW35,AW37,AW39,AW41,AW43,AY6,AY8,AY12,AY18,AY20,AY22,AY24,AY26,AY28,AY30,AY32,AY34,AY36,AY38,AY40,AY42,AY44,AY46,BA5,BA17,BA21,BA23,BA27,BA29,BA31,BA35,BA39,BA43,BA45,AM13,AM17,AM21,AM24,AM27,AM31,AM35,AM39,AH13,AH17,AH21,AH24,AH27,AH31,AH35,AH39,AE13,AE17,AE21,AE24,AE27,AE31,AE35,AE39,AA13,AA17,AA21,AA24,AA27,AA31,AA35,AA39,U13,U17,U21,U24,U27,U31,U35,U39,P13,P17,P21,P24,P27,P31,P35,P39,K13,K17,K21,K24,K27,K31,K35,K39,A1,B4,C7,A51,B48,C45,BA1,AY4,AW7,BA51,AY48,AW45,AU51,AN51,AE51,AM49,AK49,AJ51,AE51,BA37

In this reference circuit, some multi-layer ceramic chip (MLCC) capacitors (0.1/1uF) with low ESR in high frequency band can be used for EMI suppression.

NOTE

1. Both C1 and C5 are 220 μ F tantalum capacitor (ESR=0.7 Ω).
2. C3, C4, C7 and C8 are multi-layer ceramic chip (MLCC) capacitors from 0.1uF to 1uF with low ESR in high frequency band, which can be used for EMC performance.
3. D1 is used for surge protection.
4. Pins AF45, AE47, AD49, AB49, AA51, AD49, W51, U51, T49 and R47 of GND are the main ground for power return.

Table 8: Recommended D1 list

No.	Manufacturer	Part number	VRWM	Package
1	LRC	LEDZ5.1BT1G	5.1V	SOD-523
2	Prisemi	PZ5D4V2H	5.1V	SOD-523

Power supply layout guidelines:

- Both VBAT and return path should be as short and wide as possible to minimize the voltage drop.
- The width of VBAT_BB trace should be no less than 1.5mm, and the width of VBAT_RF trace should be no less than 2mm.
- These capacitors should be placed as closely as possible to the VBAT_BB and VBAT_RF pins.
- The VBAT trace should pass through zener diode and capacitors, and then pass through the VBAT pins. The small value capacitors should be placed close to the VBAT pins.
- The customer's PCB design must have a solid ground plane throughout the board as the primary

reference plane for most signals.

3.1.2 Recommended Power Supply Circuit

It is recommended to use a switching mode power supply or a linear regulator power supply. Make sure it can provide the current up to 3A at least.

Figure7 shows the linear regulator reference circuit with 5V input and 3.8V output.

Figure8 shows the switching mode power supply reference circuit with 5~12V input and 3.8V output.

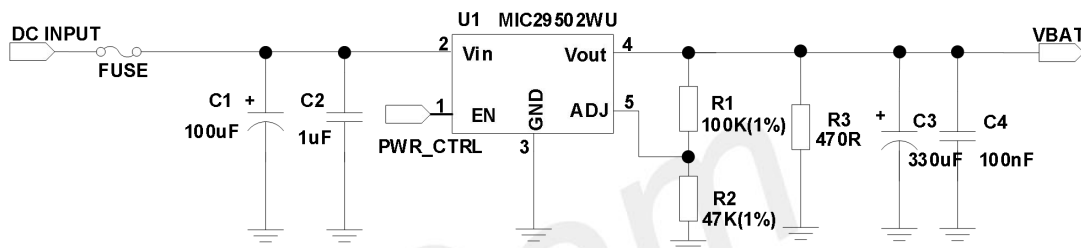

Figure 7: Linear regulator reference circuit

NOTE

An extra minimum load of R3 is required, to ensure it work properly under light load in sleep mode and power off mode. For the details about minimum load, please refer to specification of MIC29502WU.

Table 9: Recommended power chip list

No.	Manufacturer	Part number	Package
1	MICREL	MIC29502WU	TO-263

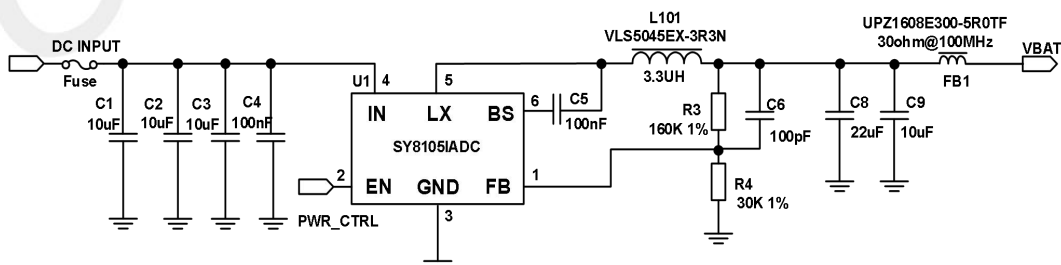

Figure 8: Switching mode power supply reference circuit

NOTE

1. In order to avoid damaging the module, please do not switch off the power supply when module works normally. Only after the module is shut down by PWRKEY or AT command, then the power supply can be cut off.
2. It is suggested that customer's design should have the ability to switch off the power supply for module in abnormal state, and then switch on the power to restart the module.
3. The PWR_CTRL signal recommend connect to the host and can be controlled.

Table 10: Recommended power chip list

No.	Manufacturer	Part number	Package
1	SILERGY	SY8105IADC	SOT23-6
2	TDK	VLS5045EX-3R3N	5*5*4.5mm
3	SUNLORD	UPZ1608E300-5R0TF	0603

3.1.3 Voltage Monitor

To monitor the VBAT voltage, the AT command “AT+CBC” can be used.

NOTE

For more details about voltage monitor commands, please refer to [Document \[1\]](#) in the appendix.

3.2 Power On and Off Module

3.2.1 Power On

Drive the PWRKEY pin to a low level and hold it for 2 seconds, then release, the module will be powered on. This pin is already pulled up internally. The electrical characteristics are listed in table 10, and the following figure shows the power on circuit.

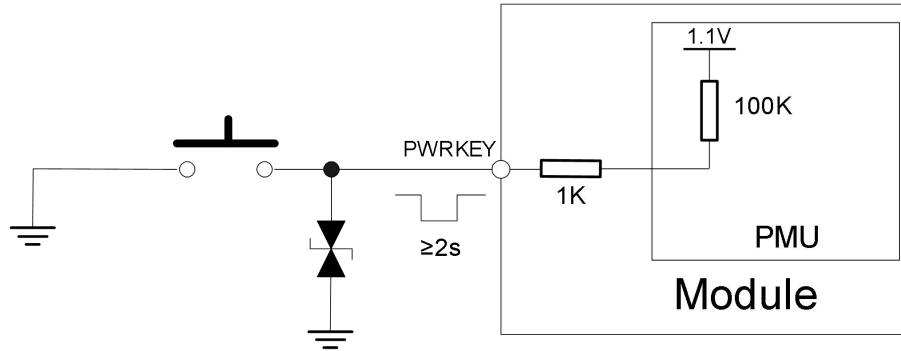

Figure 9: Power on the module use button

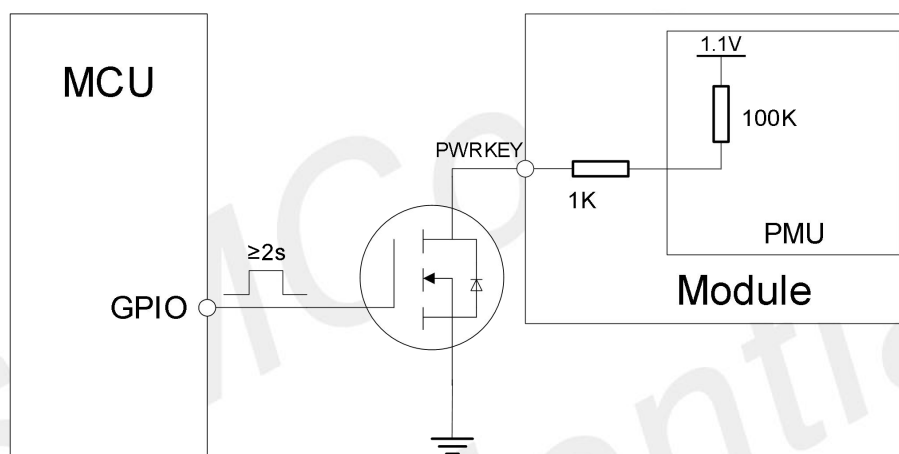

Figure 10: Power on the module use GPIO drive

Table 11: Definition of PWRKEY pin

Pin name	Pin no.	Electrical description	Description	Comment
PWRKEY	A45	DI	Power on/off the module, active low	Pull up to 1.1V internally without PM8150B

The power on sequence is shown in the following figure.

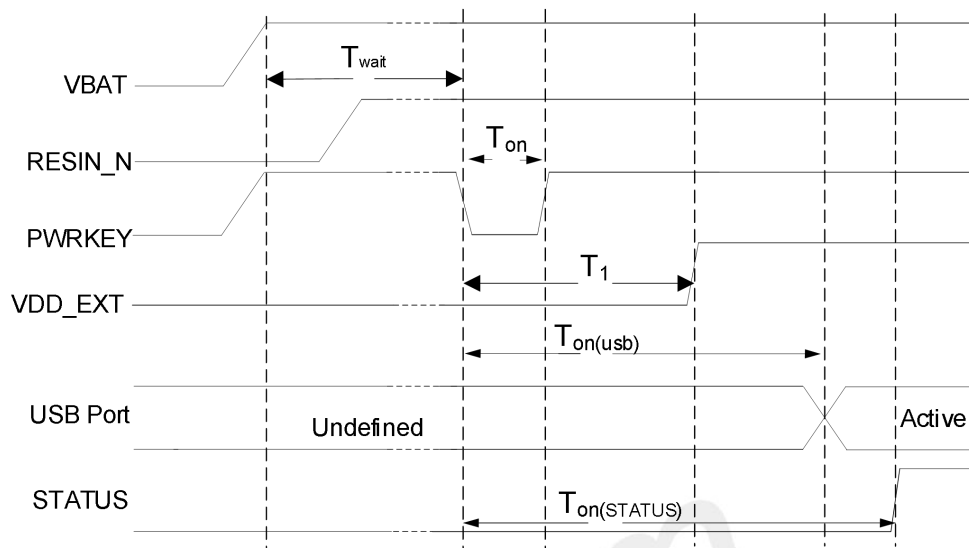

Figure 11: Power on sequence

Table 12: Power on timing and electronic characteristic

Symbol	Parameter	Min.	Typ.	Max.	Unit
T_{wait}	The waiting time from power supply available to power-on action	100	-	-	ms
T_{on}	The time of holding on PWRKEY pin to a low level	2	-	-	s
T_1	The time from power-on action to VDD_EXT ready	-	48	-	ms
$T_{on(usb)}$	The time from power-on action to USB port ready	-	12	-	s
$T_{on(STATUS)}$	The time from power-on action to STATUS ready	-	30	-	s
V_{IH}	Input high level voltage on PWRKEY pin	1.1	-	2.1	V
V_{IL}	Input low level voltage on PWRKEY pin	0	-	0.3	V

NOTE

After enter force download mode, the PWRKEY pin need to release and don't pull low always. If not, the module will restart and then cause the download fail.

3.2.2 Power Off

The following methods can be used to power off the module.

- Method 1: Power off the module by holding the PWRKEY to a low level 2 second then release.
- Method 2: Power off the module by AT command "AT+CPOF".

For details about "AT+CPOF", please refer to [Document \[1\]](#) in the appendix.

NOTE

If the temperature is outside the range of $-30\sim+70^{\circ}\text{C}$, some warning will be reported via AT port. If the temperature is outside the range of $-40\sim+85^{\circ}\text{C}$, module will be powered off automatically. For details about “AT+CPOF”, please refer to [Document \[1\]](#) in the appendix.

Normal power off action will make the module disconnect from the network, allow the software enter a safe state, and save key data before the module is powered off completely.

The power off sequence is shown in the following figure.

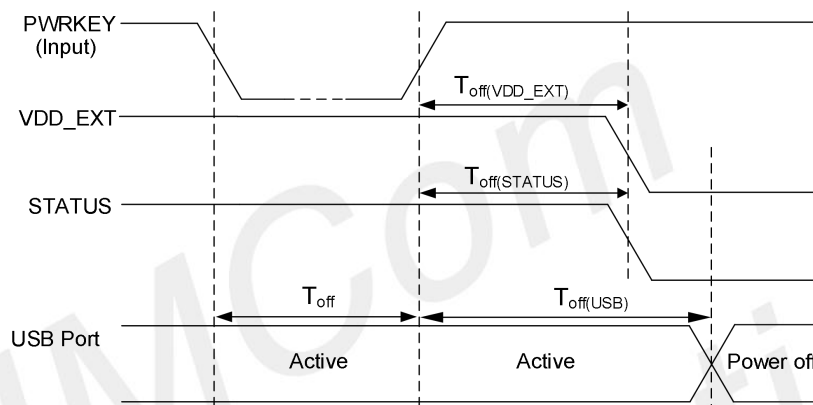

Figure 12: Power off sequence

Table 13: Power off timing and electronic characteristic

Symbol	Parameter	Time value			Unit
		Min.	Typ.	Max.	
T_{off}	The time of holding on PWRKEY pin to a low level	2	-	-	s
$T_{off(usb)}$	The time from power-off issue to USB port off	-	10	-	s
$T_{off(status)}$	The time from power-off issue to STATUS off	-	8	-	s

NOTE

After the module is shut down, please wait at least 12 seconds before turning off the power, and then power on the module.

3.3 Reset Function

Module can be reset by driving the RESIN_N pin down to a low level.

The RESIN_N signal has been internally pulled up to 1.8V, so there is no need to pull it up externally. Please refer to the following figure for the recommended reference circuit.

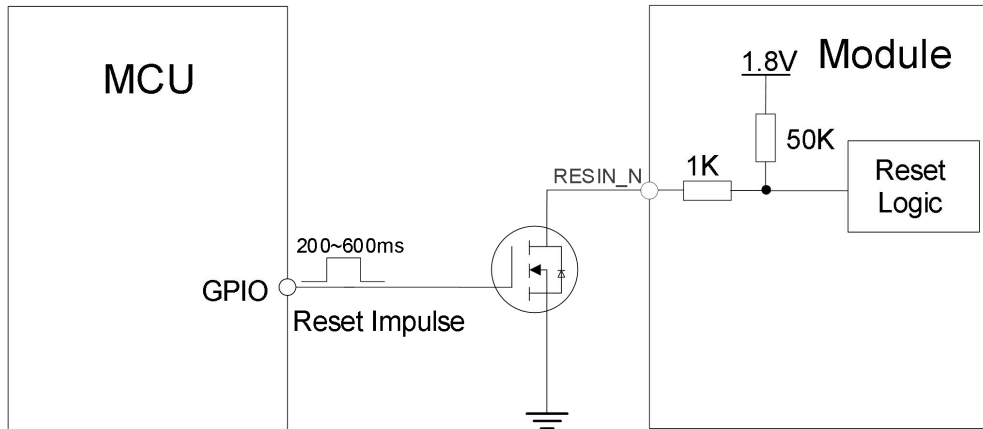

Figure 13: Reset the module use GPIO drive

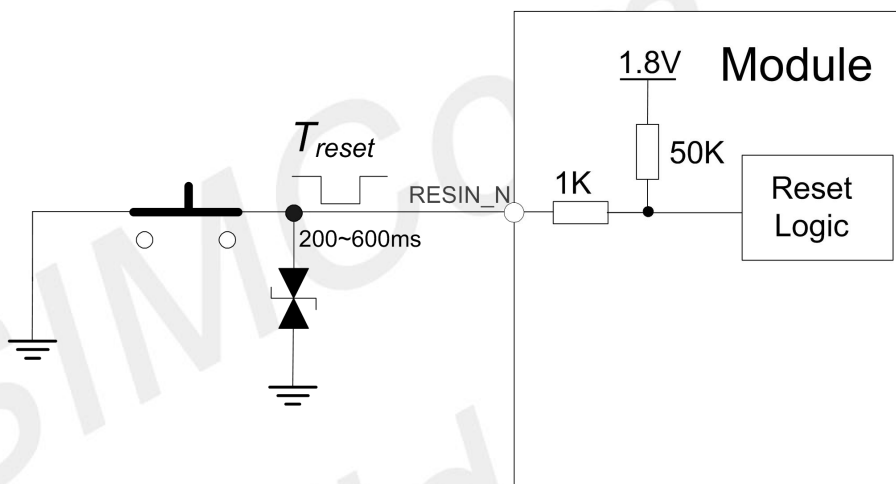

Figure 14: Reset the module use button

Table 14: Definition of RESIN_N pin

Pin name	Pin no.	Electrical description	Description	Comment
RESIN_N	A43	DI	P3	Reset the module, active low

Table 15: RESET electronic characteristics

Symbol	Description	Min.	Typ.	Max.	Unit
T_{reset}	The time of holding on RESIN_N pin to a low level	200	-	600	ms
V_{IH}	Input high level voltage	1.2	-	1.9	V
V_{IL}	Input low level voltage	0	-	0.4	V

The reset timing sequence of the module is shown in the following figure.

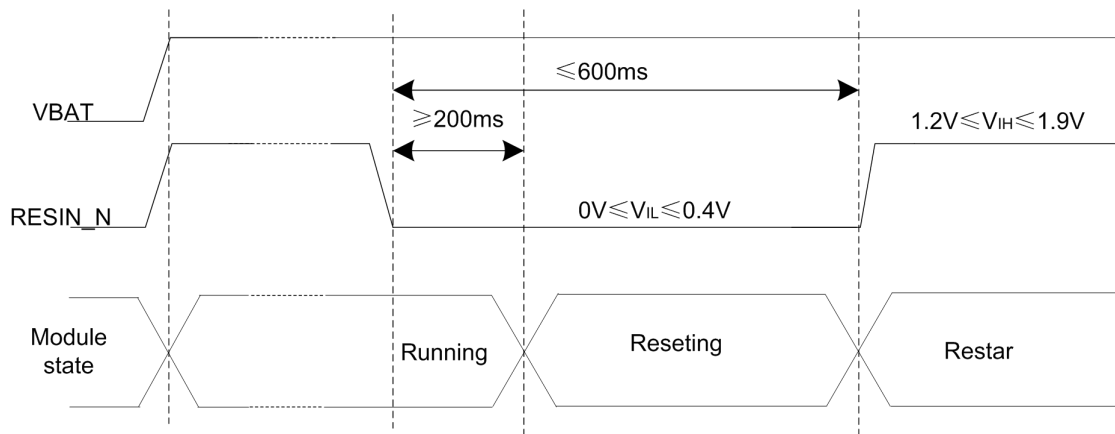

Figure 15: The reset timing sequence of the module

NOTE

Please ensure that there is no capacitance on RESIN_N pin.

3.4 Output Power Management

Table 16: Output power management summary

Pin name	Pin no	Typical voltage (V)	Rated current (mA)	Sleep state	Comment
VDD_EXT	AL5	1.8	50	LPM	Output power supply for external IO pull up circuits
S2E_1P224	M45	1.28	500	retention	Output power supply for W80 only
S3E_0P824	P49	0.88	1500	off	Output power supply for W80 only
S4E_1P904	N47	1.88	500	retention	Output power supply for W80 only
L10E_3P1	C41	3.08	30	off	Output power supply for PM8150B USB PD-PHY and USB switch
VIO_OUT	D42	1.8	0.2	on	Output power supply for PM8150B IO circuit only

3.5 USB Interface

SIM8200G have one USB controller, which complies with USB3.1 and 2.0 specifications. The high-speed PHY and super-speed PHY share the same USB 3.1 Gen2 controller, customers can choose USB3.1 or USB2.0 for their needs. USB3.1 Gen2 data rate is up to 10Gbps.

The USB interface is used for AT command communication, data transmission, GNSS NMEA output, firmware upgrade and software debugging.

SIM8200G supports USB suspend and resume mechanism, which can save power consumption. If there is no data transmission on the USB bus, module will enter suspend mode automatically.

The following figure is the USB reference circuit.

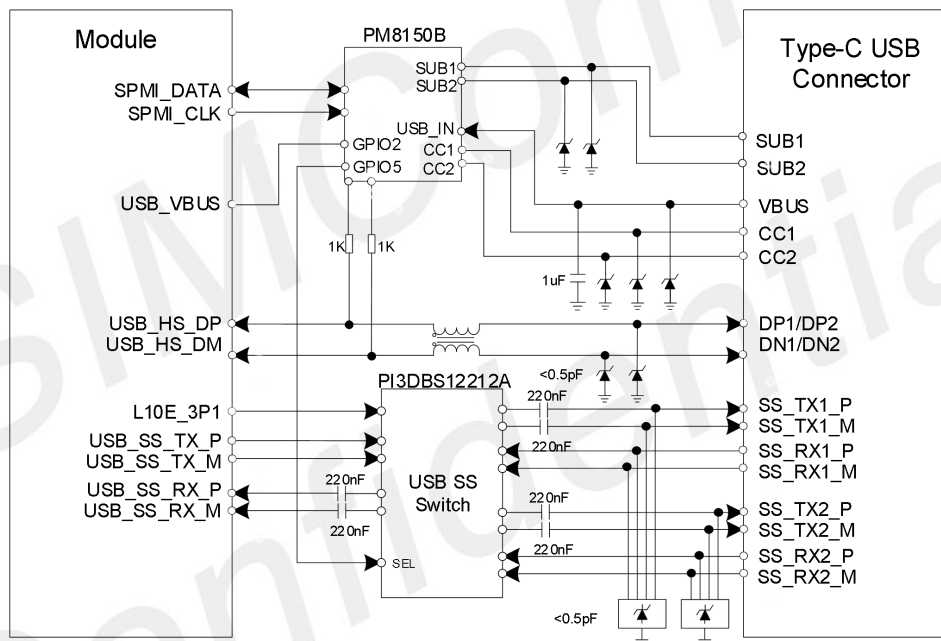

Figure 16: Type-C USB reference circuit with PM8150B

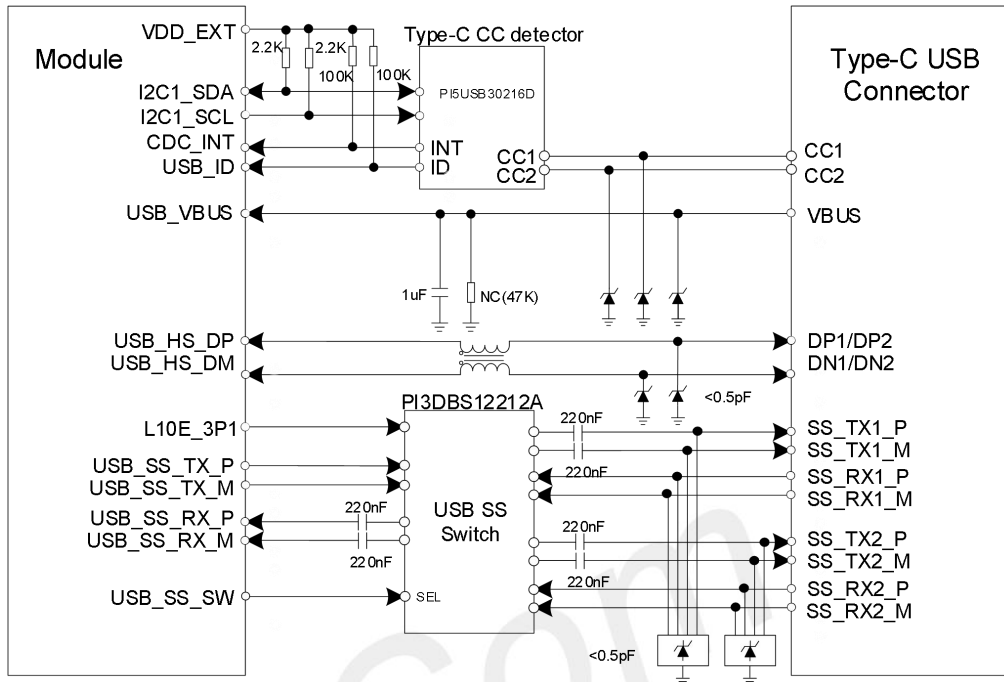

Figure 17: Type-C USB reference circuit with CC detector

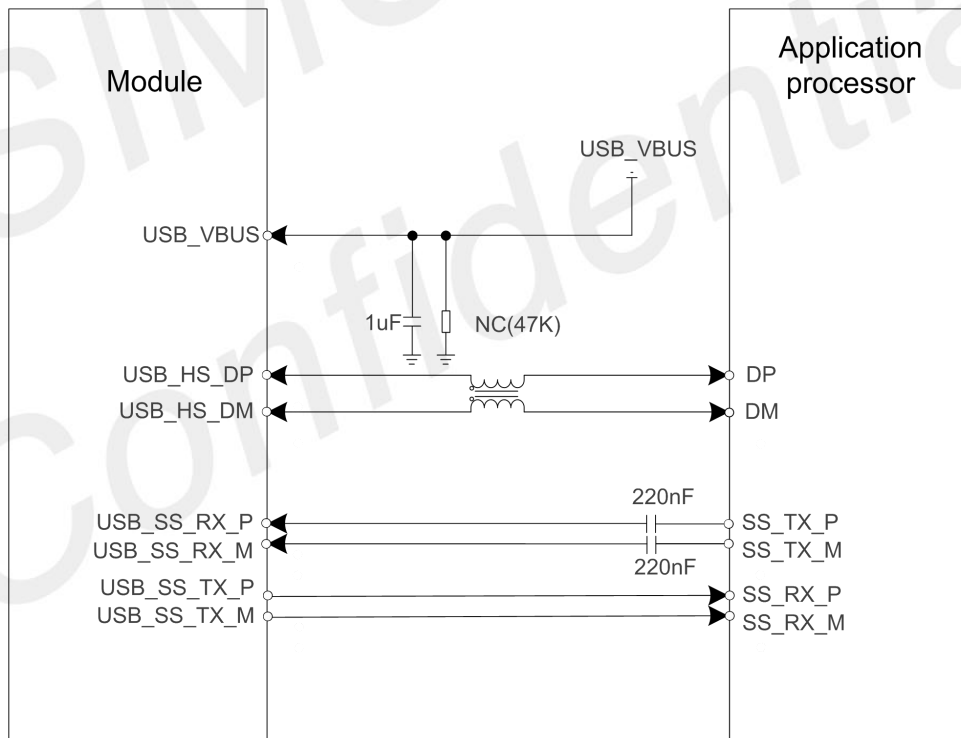

Figure 18: USB3.1 reference circuit

Table 17: Definition of USB interface

Pin name	Pin no.	Pin characteristics	Functional description	Comment
USB_VBUS	C9	AI	USB VBUS detection	Not support charge

USB_HS_DP	B6	AIO		Differential USB bi-directional data plus	Required 90Ω differential impedance Compliant with USB 2.0 standard specifications
USB_HS_DM	A5	AIO		Differential USB bi-directional data minus	
USB_SS_TX_P	A13	AO		USB3.1 super-speed transmit data plus	Required 90Ω differential Impedance Compliant with USB 3.1 standard specifications
USB_SS_TX_M	B14	AO		USB3.1 super-speed transmit data minus	
USB_SS_RX_P	B10	AI		USB3.1 super-speed receive data plus	
USB_SS_RX_M	A9	AI		USB3.1 super-speed receive data minus	
USB_ID*	C11	DI	P3	USB ID	Standard software not support this function
OTG_EN*	D10	DO	P3	USB OTG power supply DC-DC enable signal	Standard software not support this function
USB_SS_SW	C13	DO	P3	USB Type-C switch control signal	

NOTE

“*” means under development.

Table 18: Recommended CC detector list

No.	Manufacturer	Part number	Package
1	PERICOM	PI5USB30216D	QFN12

Table 19: Recommended SS USB switch list

No.	Manufacturer	Part number	Package
1	PERICOM	PI3DBS12212A	QFN3X3

Table 20: Recommended OTG 5V DC-DC and USB interface TVS list

Name	Manufacturer	Part number	Package
DC-DC	AWINIC	AW3605DNR	TDFN2X3-8L
TVS(DP/DM)	WILL	ESD5302N-3/TR	DFN1006-3L

HS USB DP/DM layout guidelines:

- Require differential trace impedance is $90\pm 10\% \Omega$.
- The intra-lane length mismatch of the differential signal lanes is less than 1mm.
- Gap from other signals keeps 3xline width.
- External components should be placed near the USB connector.
- Trace routes away from other sensitive signals (RF, audio, and 38.4M XO).
- Maximum PCB trace length cannot exceed 100mm outside of module, the shorter trace and more better.

SS USB TX/RX layout guidelines:

- Require differential trace impedance is $90\pm 10\% \Omega$.
- The intra-lane length mismatch of the differential signal lanes is less than 500um.
- Gap from other signals keeps 4xline width.
- Gap between Rx-to-Tx keeps 4xline width.
- External components should be placed near the USB connector.
- Trace routes away from other sensitive signals (RF, especially 2.4 GHz).
- Route differential pairs in the inner layers with a solid GND reference to have good impedance control and to minimize discontinuities.
- Keep isolation between the Tx pair, Rx pair, and DP/DM to avoid crosstalk.
- If core vias are used, use no more than two core vias per signal line to limit stubs.

3.6 PCIe Interface

SIM8200G support PCIe Gen3 2-lane interfaces, and can be used as EP or RC mode. The data rate up to 8Gbps per lane. The following figure is the PCIe reference circuit.

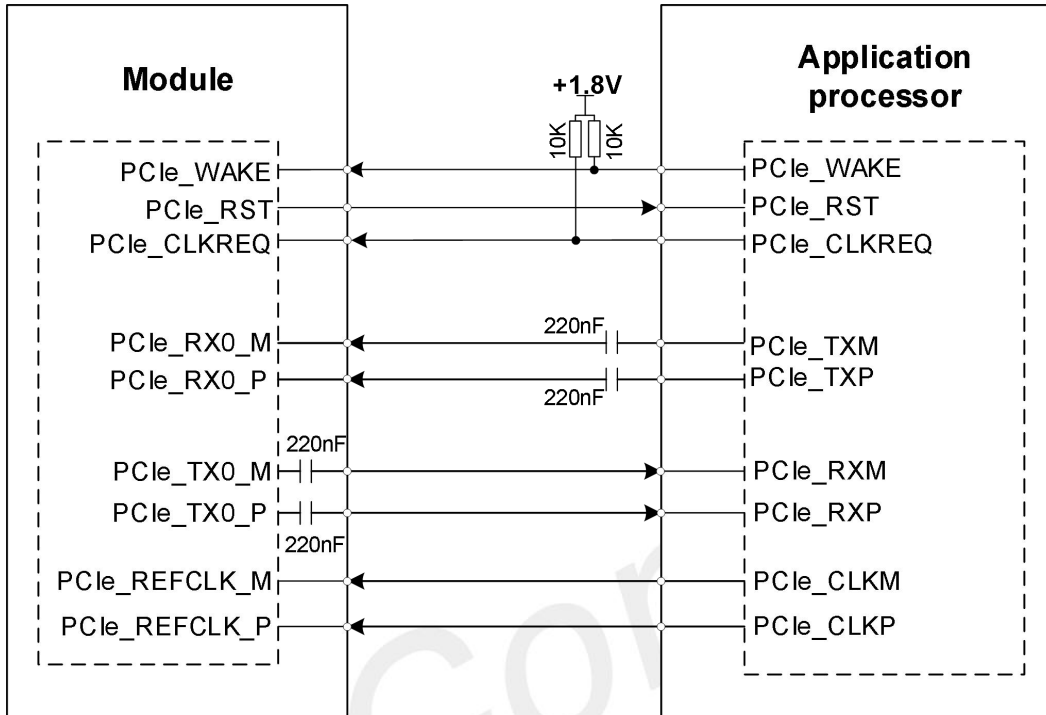

Figure 19: PCIe interface reference circuit (RC)

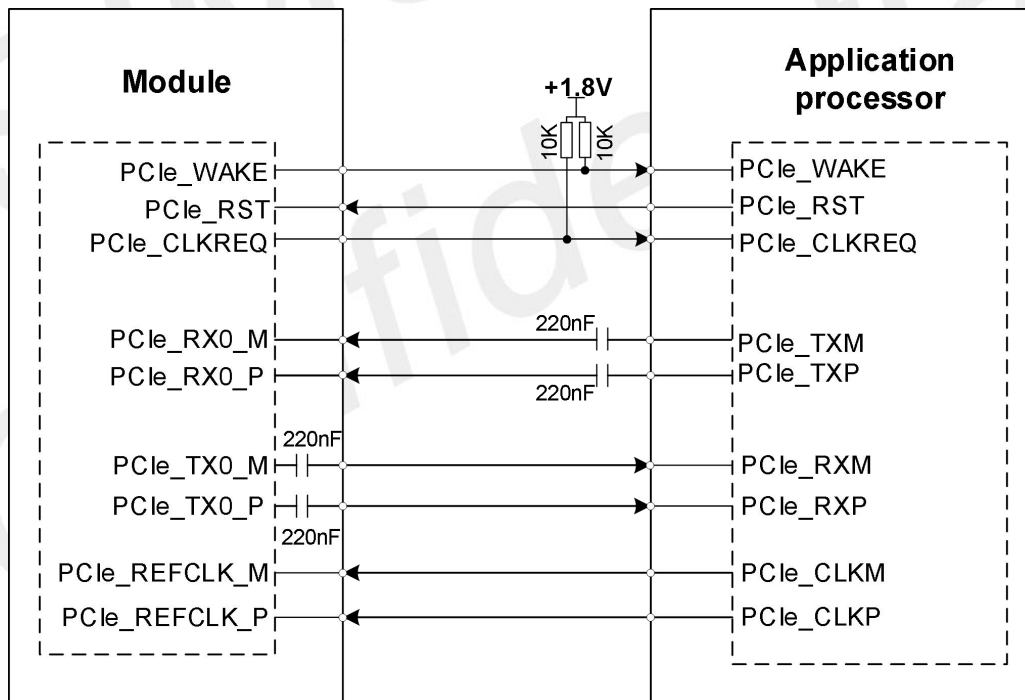

Figure 20: PCIe interface reference circuit (EP)

NOTE

The AC capacitors of PCIe_TXM and PCIe_TXP should be placed near the AP.

Table 21: Definition of PCIe interface

Pin name	Pin no.	Pin characteristics		Functional description	Comment
PCIe_REFCLK_P	B22	AIO		PCIe reference clock plus	Required 90Ω differential impedance
PCIe_REFCLK_M	A21	AIO		PCIe reference clock minus	
PCIe_TX0_M	B18	AO		PCIe transmit0 minus	
PCIe_TX0_P	A17	AO		PCIe transmit0 plus	
PCIe_TX1_M	B20	AO		PCIe transmit1 minus	
PCIe_TX1_P	A19	AO		PCIe transmit1 plus	
PCIe_RX0_M	A25	AI		PCIe receive0 minus	
PCIe_RX0_P	B26	AI		PCIe receive0 plus	
PCIe_RX1_M	A23	AI		PCIe receive1 minus	
PCIe_RX1_P	B24	AI		PCIe receive1 plus	
PCIe_CLKREQ	C21	DI	P3	PCIe clock request	PCIe_CLKREQ and PCIe_WAKE need pull up to VDD_EXT externally, Default as RC mode
PCIe_WAKE	C25	DI	P3	PCIe wake-up	
PCIe_RST	C23	DO	P3	PCIe reset	

PCIe interface layout guidelines:

- All other sensitive/high-speed signals and circuits must be protected from PCIe corruption.
- PCIe signals must be protected from noisy signals (clocks, SMPS).
- Each trace needs to be adjacent to a ground plane.
- Require differential trace impedance is $90 \pm 10\% \Omega$.
- The intra-lane length mismatch of the differential signal lanes is less than 500um.
- Gap from other signals keeps 4xline width.
- Gap between Rx-to-Tx keeps 4xline width.
- Maximum PCB trace length cannot exceed 150mm outside of module, the shorter trace and more better.

3.6.1 PCIe for W80

PCIe Gen3 lane0 can be connected to W80 as WLAN data interface, SIM8200 module serves as RC and W80 module serves as EP. PCIe_CLKREQ and PCIe_WAKE already be pulled up to 1.8V in the W80 module. The details design please refer to the reference circuit document. The following figure is the PCIe reference circuit.

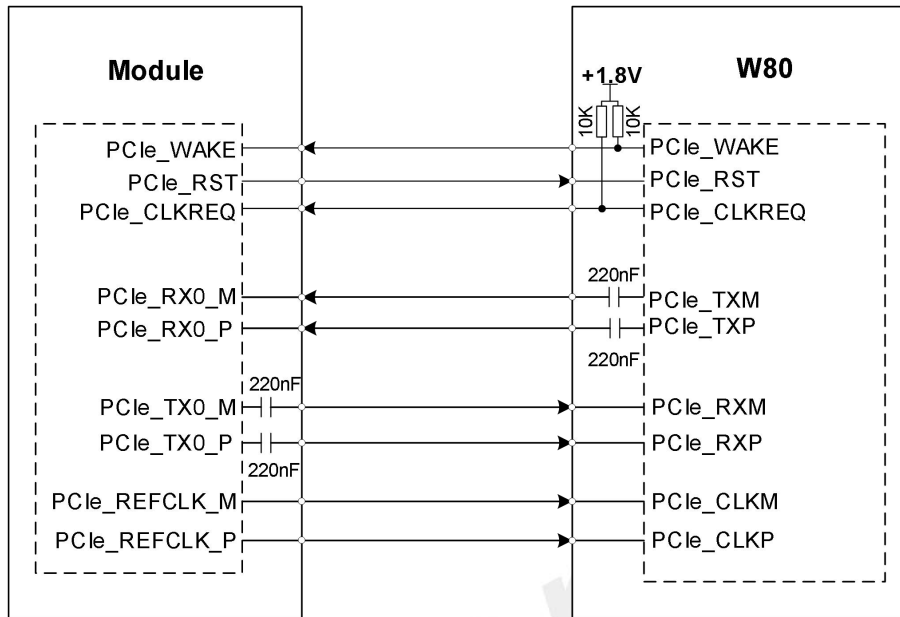

Figure 21: PCIe interface reference circuit (RC) for W80

NOTE

The voltage domain of PCIe_WAKE, PCIe_RST, PCIe_CLKREQ is 1.8V when using.

Table 22: Recommended W80 list

Name	Manufacturer	Model
W80	SIMCOM	S2-1096M

3.6.2 PCIe for RTL8125B

PCIe Gen3 lane0 can be connected to RTL8125B-TE as Ethernet data interface, SIM8200 module serves as RC and RTL8125B-TE serves as EP. PCIe_CLKREQ and PCIe_WAKE need to be pulled up to 3.3V out of the module. The details design please refer to the reference circuit document. The following figure is the PCIe reference circuit.

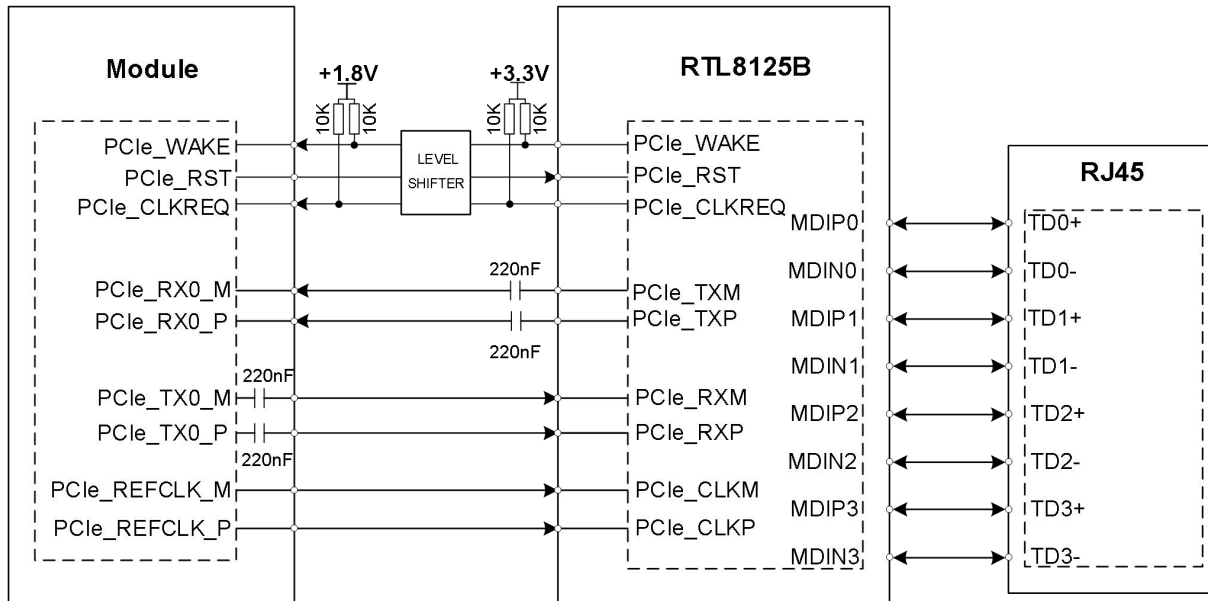

Figure 22: PCIe interface reference circuit (RC) for RTL8125B

NOTE

1. The AC capacitors of PCIe_TXM and PCIe_TXP should be placed near the RTL8125B.
2. The voltage domain of PCIe_WAKE, PCIe_RST, PCIe_CLKREQ is 3.3V when using.
3. For more details about PCIe to Ethernet, please refer to [Document \[18\]](#) in the appendix.

Table 23: Recommended RTL8125B list

Name	Manufacturer	Model
RTL8125B	REALTEK	RTL8125B-CG

3.6.3 PCIe Switch

When PCIe switch is added, the module can use W80 and RTL8125B at the same time. The details design please refer to the reference circuit document. The following figure is the PCIe reference circuit.

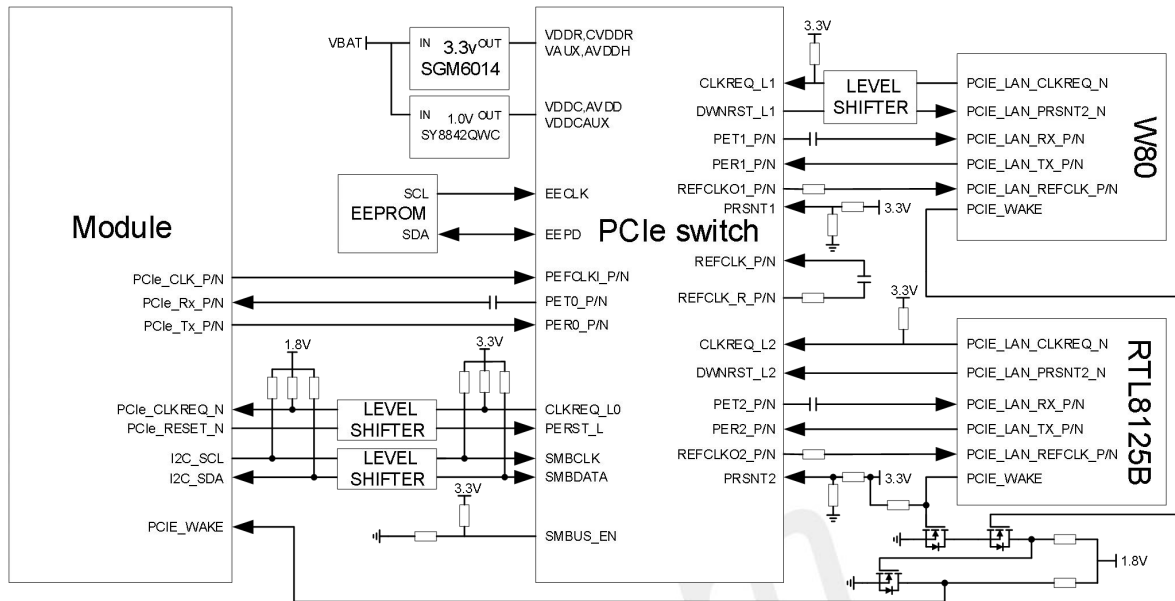

Figure 23: PCIe switch reference circuit

NOTE

1. The AC capacitors of PCIe_TXM and PCIe_TXP should be placed near the AP.
2. The PCIe control signal voltage domain of the module and W80 are 1.8V, and the RTL8125B and PCIe SWITCH are 3.3V.

Table 24: Recommended PCIe SWITCH list

Name	Manufacturer	Model
PCIe Switch	DIODES	PI7C9X2G304EVAZXAEX
Level Shifter	TI	TXS0104EYZT
Level Shifter	TEAXS	PCA9306DCUR
EEPROM	MICROCHIP	24LC04B-I/SN
LDO 1.0V	SILERGY	SY8842QWC
LDO 3.3V	SGMICRO	SGM6014-ADJYTD10G/TR

3.7 SDIO Interface

SIM8200G supports 8-bit SDIO interface, which meets the SDIO3.0 specifications and supports SDIO host mode. The clock output up to 200MHz for SD card, and up to 100MHz for eMMC. Support 4-bit dual-voltage 1.8V or 3.0V SD card or 8-bit 1.8V eMMC.

Figure21 shows the SD card reference circuit.

Figure22 shows the eMMC reference circuit.

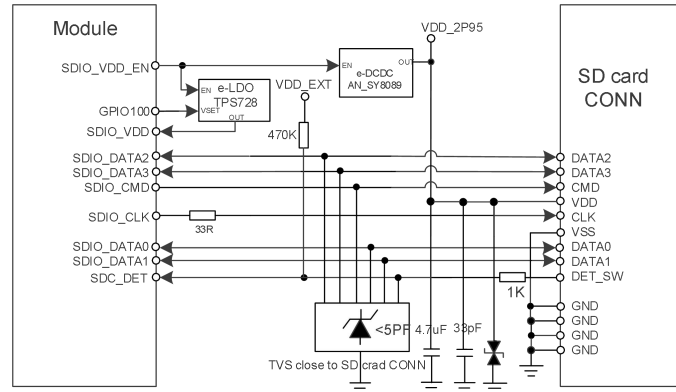

Figure 24: SD card reference circuit

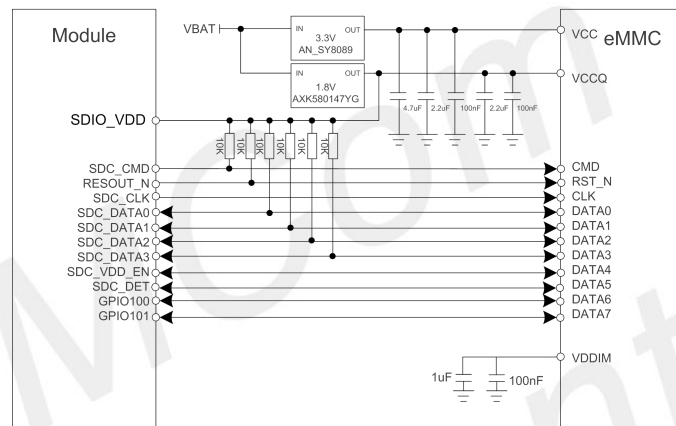

Figure 25: eMMC reference circuit

Table 25: Definition of SDIO interface

Pin name	Pin no.	Pin characteristics	Functional description	Comment
SDIO_VDD ¹	F7	PI 1.8/3.0V	Power input for internal SDIO circuit	
SDIO_DATA0	B1	DIO P2	SDC data bit 0 or eMMC* data bit 0	
SDIO_DATA1	C1	DIO P2	SDC data bit 1 or eMMC data bit 1	
SDIO_DATA2	D3	DIO P2	SDC data bit 2 or eMMC data bit 2	Required 50Ω impedance
SDIO_DATA3	F3	DIO P2	SDC data bit 3 or eMMC data bit 3	
SDIO_CMD	G5	DIO P2	SDC command output	
SDIO_CLK	E5	DO P2	SDC clock output	
SDIO_VDD_EN	H7	DO P3	Enable the SD card power or eMMC data bit 4	If used as eMMC data signals, required 50Ω impedance
SDIO_DET	E1	DI P3	SD card insertion detect or eMMC data bit 5	
GPIO100	H3	DIO P3	eMMC data bit 6	

GPIO101	K7	DIO	P3	eMMC data bit 7	
RESOUT_N	AW17	DO	P3	eMMC RST_N	Module SN: S2-109WT supports this function

NOTE

1. If not use SDIO interface, the SD_VDD pin should connect to VDD_EXT out of the module.
2. Support eMMC function PN number of the module is S2-109WT, for details please contact SIMCom support teams.

Table 26: Recommended TVS and SD card socket list

Name	Manufacturer	Model
TVS	ON	ESD9L5.0ST5G
SD card socket	ALPS	SCHA4B0400
eMMC	SanDisk	SDINBDG4_8G

SDIO interface layout guidelines:

- Require trace impedance is 36 to 50Ω.
- CLK to DATA/CMD length mismatch is less than 0.5mm.
- 30–35Ω termination resistance on clock net and placed close to the module.
- Gap from other signals keeps 1.5xline width.
- Gap lane-to-lane 1.5xline width.
- Bus capacitance load is less than 5pF.
- Trace routes away from other sensitive signals.
- Maximum PCB trace length cannot exceed 30mm out of the module for 104Mbps data rate, the shorter trace and more better.
- Maximum PCB trace length cannot exceed 100mm out of the module for 50Mbps data rate, the shorter trace and more better.

3.8 RGMII Interface

SIM8200G supports RGMII interface, data rate up to 1000Mbps, customers can use AR8035 convert to RJ45 interface out of the module. The reference circuit is as follows:

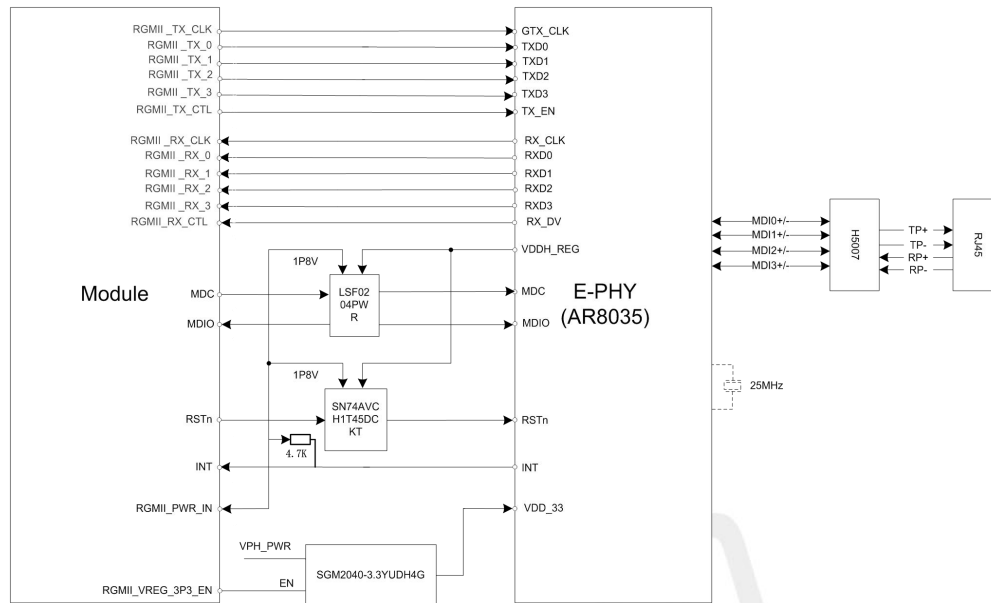

Figure 26: RGMII to RJ45 diagram circuit

Table 27: Definition of RGMII interface

Pin name	Pin no.	Pin characteristics		Functional description	Comment
RGMII_MD_IO	D30	DIO	P8	RGMII management data	
RGMII_MD_CLK	D34	DO	P8	RGMII management data clock	
RGMII_RX_CTL	A35	DI	P8	RGMII receive control	
RGMII_RX_CLK	B36	DI	P8	RGMII receive clock	
RGMII_RX_0	B40	DI	P8	RGMII receive data bit 0	
RGMII_RX_1	A37	DI	P8	RGMII receive data bit 1	
RGMII_RX_2	B38	DI	P8	RGMII receive data bit 2	Required 50Ω impedance
RGMII_RX_3	A39	DI	P8	RGMII receive data bit 3	
RGMII_TX_CTL	A33	DO	P8	RGMII transmit control	
RGMII_TX_CLK	B34	DO	P8	RGMII transmit clock	
RGMII_TX_0	A31	DO	P8	RGMII transmit data bit 0	
RGMII_TX_1	B30	DO	P8	RGMII transmit data bit 1	
RGMII_TX_2	A29	DO	P8	RGMII transmit data bit 2	
RGMII_TX_3	B32	DO	P8	RGMII transmit data bit 3	
RGMII_INT_N	C39	DI	P3	Interrupt input from RGMII PHY	
RGMII_RST_N	C29	DO	P3	Reset output to RGMII PHY	
RGMII_PWR_EN	D36	DO	P3	Used to enable external LDO to supply 2.5V power to RGMII_PWR_IN	
RGMII_PWR_IN ¹	D32	PI	1.8V	Power supply input for internal RGMII circuit	
RGMII_3P3_EN	D38	DO	P3	Used to enable external DC-DC/LDO to supply 3.3V	

NOTE

3. If not use RGMII interface, the RGMII_PWR_IN pin should connect to VDD_EXT out of the module.

RGMII interface layout guidelines:

- Require trace impedance is $50\Omega \pm 10\%$.
- TX to TX_CLK, TX_DATA length mismatch is less than 5mm.
- RX to RX_CLK, RX_DATA length mismatch is less than 5mm.
- Gap within TX bus or RX bus keeps 2xline width.
- Gap to other signals keeps 3xline width.
- Gap RX-to-TX keeps 2xline width.
- Trace routes away from sensitive signals.
- Maximum PCB trace length cannot exceed 100mm out of the module, the shorter trace and more better.

3.9 (U)SIM Interface

SIM8200G supports two (U)SIM cards but single standby. (U)SIM1 and (U)SIM2 are dual-voltage 1.8 V or 3.0 V interfaces.

Table 28: (U)SIM electronic characteristics in 1.8V mode ((U)SIM_PWR=1.8V)

Symbol	Parameter	Min.	Typ.	Max.	Unit
(U)SIM_VDD	Power supply for (U)SIM card	1.65	1.8	1.95	V
V _{IH}	High-level input voltage	1.26	-	1.95	V
V _{IL}	Low-level input voltage	0	-	0.36	V
V _{OH}	High-level output voltage	1.44	-	1.8	V
V _{OL}	Low-level output voltage	0	-	0.4	V

Table 29: (U)SIM electronic characteristics 3.0V mode ((U)SIM_PWR=3.0V)

Symbol	Parameter	Min.	Typ.	Max.	Unit
(U)SIM_VDD	Power supply for (U)SIM card	2.7	3.0	3.05	V
V _{IH}	High-level input voltage	2.1	-	3.05	V
V _{IL}	Low-level input voltage	0	-	0.6	V
V _{OH}	High-level output voltage	2.4	-	3.0	V

V_{OL}	Low-level output voltage	0	-	0.4	V
----------	--------------------------	---	---	-----	---

The module supports (U)SIM card hot-swap function through the (U)SIM_DET pin, which is a level trigger pin. The USIM_DET pin requires pull up externally.

The following figure shows (U)SIM card reference circuit.

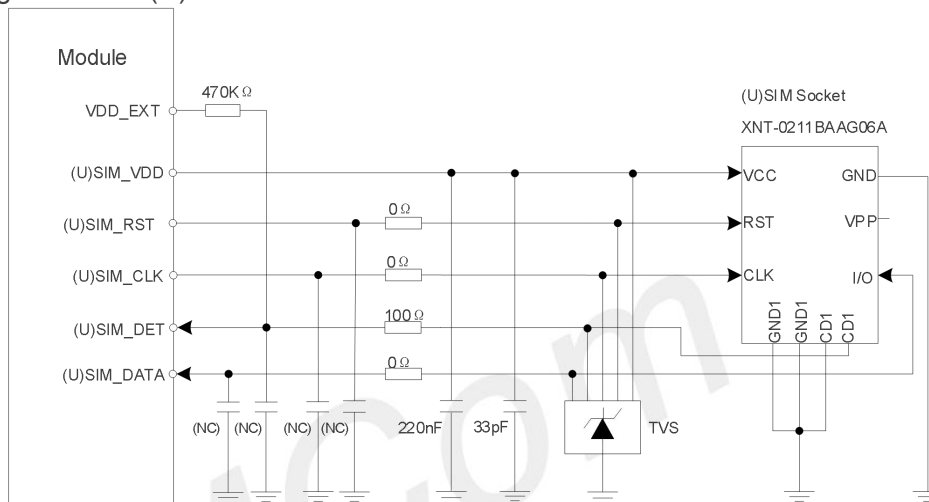

Figure 27: (U)SIM interface reference circuit

After inserting (U)SIM card, the (U)SIM_DET pin will change from low to high level. The falling edge will indicate that the (U)SIM card has been inserted. After removing the (U)SIM card, the (U)SIM_DET pin will change from high to low level. This rising edge will indicate the removal of the (U)SIM card.

Using “AT+UIMHOTSWAPON=0 or 1” and “AT+UIMHOTSWAPLEVEL=0 or 1” AT command to set module SIM card hot swap function enable and SIM card detection level, for more details, please refer to SIM8200 Series_AT Command Manual document.

Using “AT+SMSIMCFG=1,1” and “AT+SMSIMCFG=1,2” AT command to switch (U)SIM1 and (U)SIM2 function, for more details, please refer to SIM8200 Series_AT Command Manual document.

Table 30: Definition of (U)SIM interface

Pin name	Pin no.	Pin characteristics	Functional description	Comment	
(U)SIM1_VDD	B51	PO	P4	Power supply for (U)SIM1 card	1.8/3.0V voltage domain, (U)SIM interface should be protected against ESD. If unused, please keep open
(U)SIM1_DATA	E51	DIO	P4	(U)SIM1 card data signal, which has been pulled up to (U)SIM1_VDD by a 20K resistor internally	
(U)SIM1_CLK	D49	DO	P4	(U)SIM1 clock signal	
(U)SIM1_RST	C51	DO	P4	(U)SIM1 reset signal	
(U)SIM1_DET	E47	DI	P3	(U)SIM1 card detect signal, which need pulled up to VDD_EXT by a 470K resistor externally	

(U)SIM2_VDD	F49	PO	P5	Power supply for (U)SIM2 card
(U)SIM2_DATA	G47	DIO	P5	(U)SIM2 card data, which has been pulled up to (U)SIM2_VDD by a 20K resistor internally
(U)SIM2_CLK	H49	DO	P5	(U)SIM2 clock signal
(U)SIM2_RST	G51	DO	P5	(U)SIM2 reset signal
(U)SIM2_DET	F45	DI	P3	(U)SIM2 card detect, which need pulled up to VDD_EXT by a 470KR resistor externally

The following table shows recommended TVS of ESD protect and (U)SIM socket.

Table 31: Recommended TVS and (U)SIM socket list

Name	Manufacturer	Model
TVS	ST	ESDA6V1-5W6
(U)SIM socket	Suntech	XNT-0211BAAG06A

If the (U)SIM card hot-swap function is not used, customers should keep the (U)SIM_DET pin open.

The (U)SIM card layout guidelines:

- Make sure that the (U)SIM card socket should be far away from the antennas.
- (U)SIM traces should be away from RF, VBAT and high-speed signals.
- The traces should be as short as possible.
- Keep (U)SIM socket's GND pin directly connect to the main ground.
- Shielding the (U)SIM card signals by ground.
- Recommended to place a 33pF~1uF capacitor on (U)SIM_VDD net and place close to the holder.
- The rise/fall time of (U)SIM_CLK should not exceed 40ns.
- The parasitic capacitance of TVS should not exceed 60pF, and the TVS should be placed close to the (U)SIM socket.

3.10 I2S Interface

SIM8200G supports one I2S/PCM interface for external codec, which meets the requirements in the Phillips I2S bus specification.

Table 32: I2S format

Characteristics	Specification
Line interface format	Linear(fixed)
Data length	16bits(fixed)
I2S flock/sync source	Master mode(fixed)

I2S clock rate	1.536 MHz (default)
I2S MCLK rate	12.288MHz (default)
Data ordering	MSB

NOTE

For more details about I2S AT commands, please refer to [document \[1\]](#) in the appendix.

3.10.1 I2S Timing

The module supports I2S sampling rate of 48 KHz and 32 bit coding signal (16 bit length), the timing sequence is shown in the following figure.

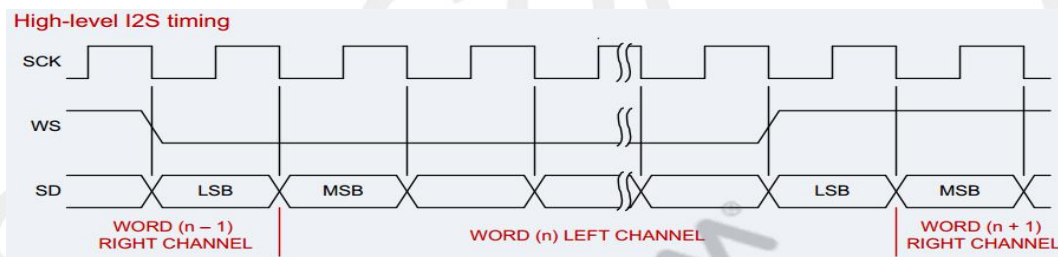

Figure 28: I2S timing

Table 33: I2S timing parameters

Signal	Parameter	Description	Min.	Typ.	Max.	Unit
I2S_MCLK	Frequency	Frequency	–	12.288	12.288	MHz
	T	Clock period	81.380	81.380	–	ns
	t(HC)	Clock high	0.45T	–	0.55T	ns
	t(LC)	Clock low	0.45T	–	0.55T	ns
I2S_CLK	Frequency	Frequency	8	48	48	KHz
	T	Clock period	20.83	20.83	125	us
	t(HC)	Clock high	0.45T	–	0.55T	ns
	t(LC)	Clock low	0.45T	–	0.55T	ns
I2S_WS	t(sr)	DIN/DOUT and WS input setup time	16.276	–	–	ns
	t(hr)	DIN/DOUT and WS input hold time	0	–	–	ns
	t(dtr)	DIN/DOUT and WS output delay	–	–	65.10	ns
	t(htr)	DIN/DOUT and WS output hold time	0	–	–	ns

3.10.2 I2S Reference Circuit

The following figure shows the external codec reference design.

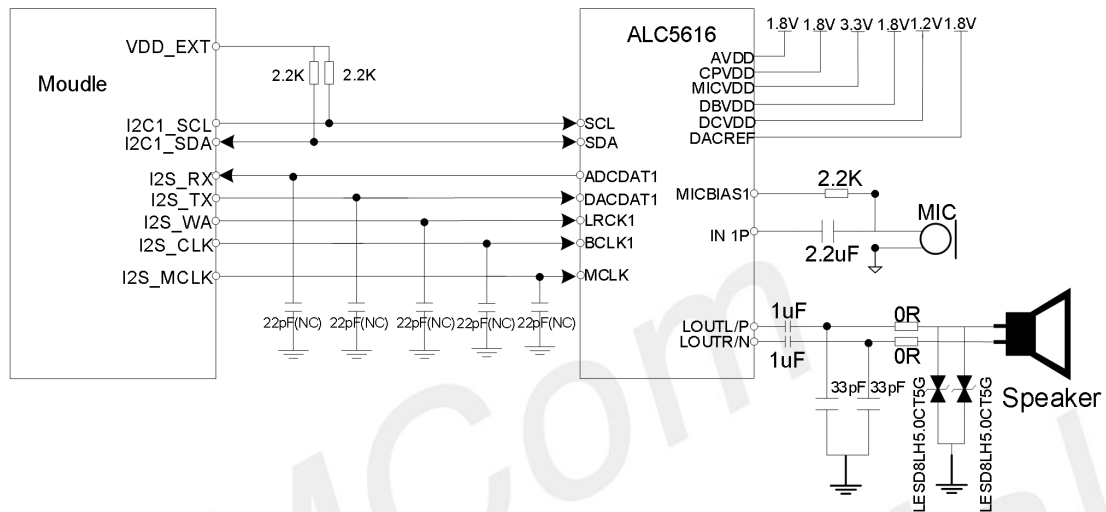

Figure 29: Audio codec reference circuit

The PCM interface is multiplexing with I2S interface. The default audio interface of the module is I2S.

Table 34: The PCM interface is multiplexing with I2S interface

Pin name	Pin no.	Electrical description	Description	Comment
I2S_DOUT/ PCM_DOUT	N1	DO	P3	Default is I2S interface, can be configured as PCM interface by software, If unused, please keep open
I2S_DIN/ PCM_DIN	R1	DI	P3	
I2S_CLK/ PCM_CLK	P3	DO	P3	
I2S_WS/ PCM_SYNC	T3	DIO	P3	
I2S_MCLK	L1	DO	P3	

Audio layout guidelines:

Analog input

- 0.2mm trace widths; 0.2mm spacing between traces.
- Pseudo differential route for MIC.
- Isolate from noise sources, such as antenna, RF signals, SMPS, clocks, and other high speed signals.

Analog output

- Isolate from noise sources such as antenna, RF signals, SMPS, clocks, and other digital signals with fast transients.

- Speaker output signal – route as differential pair with 0.5mm trace widths.

3.11 I2C Interface

SIM8200G support two I2C interfaces, meet I2C specification version 5.0, and data rate up to 400 Kbps.

The following figure shows the I2C bus reference circuit.

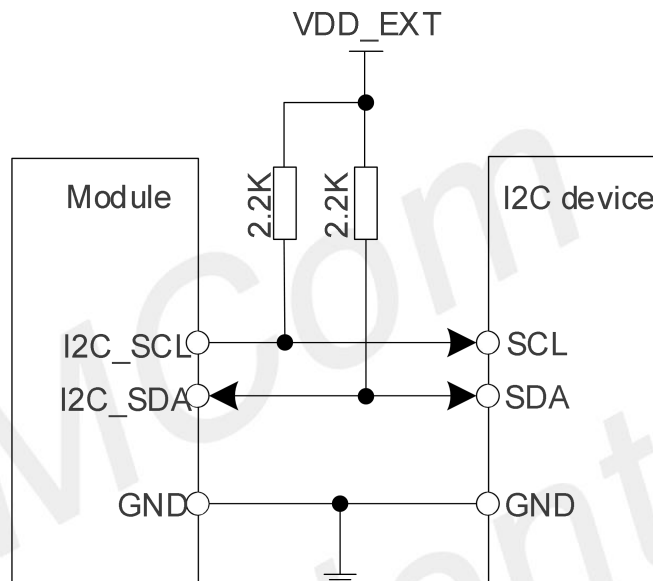

Figure 30: I2C reference circuit

Table 35: Definition of I2C interface

Pin name	Pin no.	Electrical description	description	Comment
I2C1_SCL	M7	OD	P3	I2C1 default use for codec
I2C1_SDA	P7	OD	P3	Pull up to VDD_EXT externally
I2C2_SCL	AB7	OD	P3	I2C2 default use for sensor
I2C2_SDA	Y7	OD	P3	Pull up to VDD_EXT externally

NOTE

1. SDA and SCL need to pull up to VDD_EXT by a 2.2K resistor externally.
2. For more details about AT commands please refer to [document \[1\]](#) in the appendix.

3.12 UART Interface

SIM8200G supports 3 UART ports for communication, which data rate up to 4Mbps. All the UART level of SIM8200G is 1.8V. If it communicates with the 3.3V serial port level, a level conversion chip needs to be added in the middle. It is recommended to use TI's TXS0104EPWR level shift, the reference circuit is as follows.

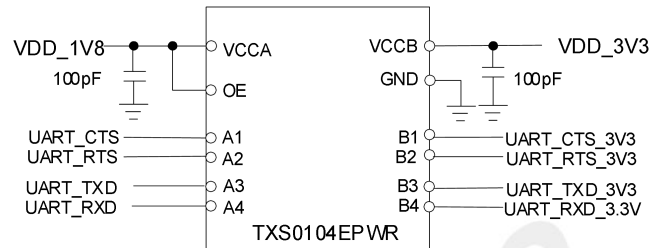

Figure 31: UART level conversion circuit

The following level shifting circuits can also be used:

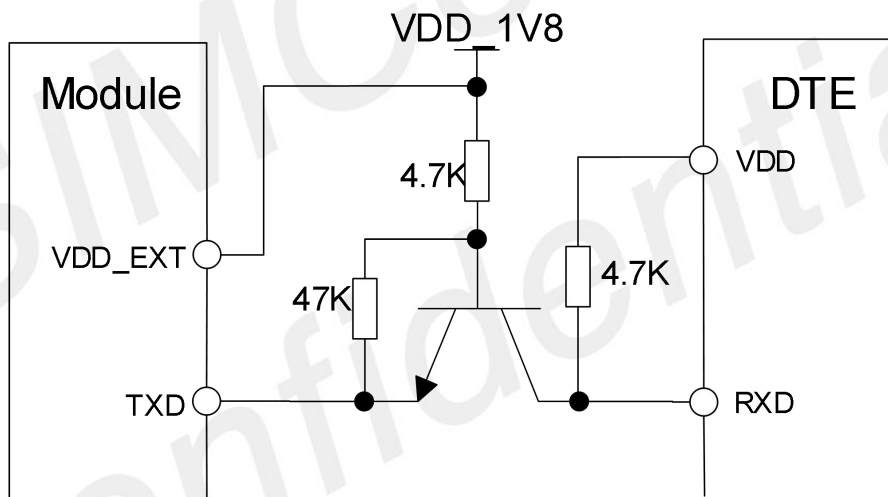

Figure 32: UART TX level conversion circuit

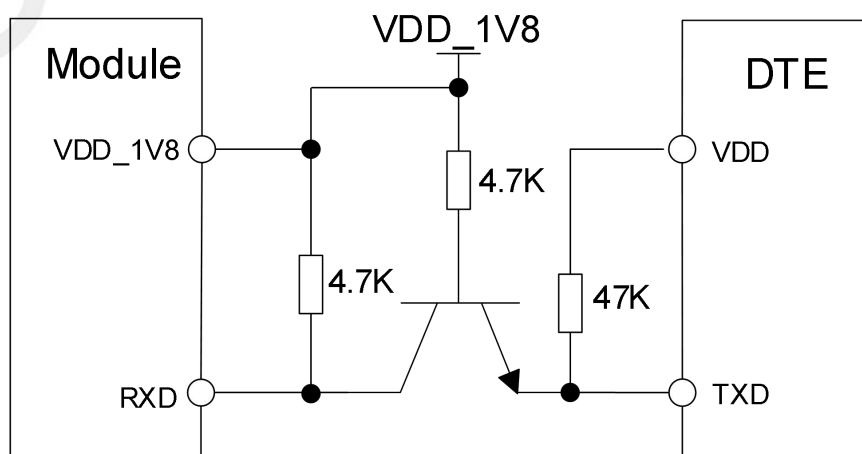

Figure 33: UART RX level conversion circuit

Table 36: Definition of UART interface

Pin name	Pin no.	Electrical description	description	Comment
UART1_CTS	AA1	DI	Clear to send	
UART1_RTS	AC1	DO	Request to send	Default use for AT command
UART1_TXD	AB3	DO	Transmit data	
UART1_RXD	AD3	DI	Receive data	
UART1_DCD	W5	DO	Carrier detect	
UART1_RI	AA5	DO	Ring indicator	
UART1_DTR	AC5	DI	Data terminal ready	
UART2_CTS	V3	DI	Clear to send	UART2 and BT_UART cannot be used at the same time
UART2_RTS	Y3	DO	Request to send	
UART2_TXD	U1	DO	Transmit data	
UART2_RXD	W1	DI	Receive data	
BT_UART_CTS	R5	DI	Clear to send	
BT_UART_RTS	U5	DO	Request to send	Default use for BT
BT_UART_TXD	T7	DO	Transmit data	
BT_UART_RXD	V7	DI	Receive data	
DBG_UART_RXD	L5	DI	Receive data	Used for debug only
DBG_UART_TXD	N5	DO	Transmit data	

NOTE

1. The 4-wire UART interface support flow control function.
2. UART2 and BT_UART cannot be used at the same time.
3. BT_UART_TXD is boot configure pin of the module, cannot be pull up or pull down before powering on the module.

3.13 SPI Interface

SIM8200G SPI interface only supports master mode, data rate up to 50MHz. Usually, SPI interface is used to connect ROM or LCD and other devices.

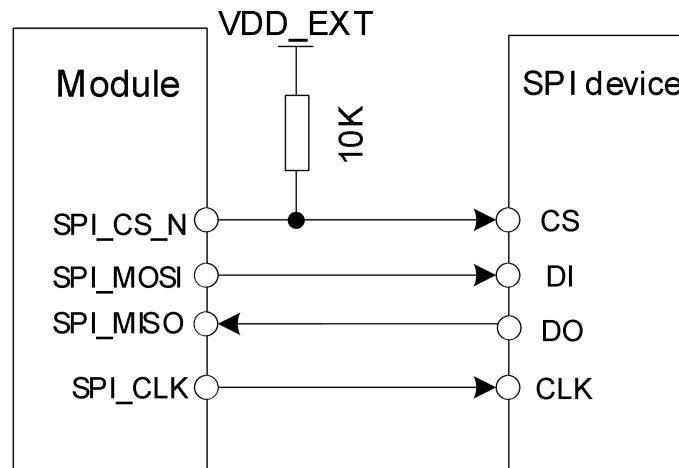

Figure 34: SPI reference circuit

Table 37: Definition of SPI interface

Pin name	Pin no.	Electrical description	description	Comment
SPI_CS_N	D18	DO	SPI chip select	
SPI_CLK	D20	DO	SPI clock	
SPI_MOSI	D14	DO	Master output slaver input	
SPI_MISO	D16	DI	Master input slaver output	

3.14 ADC Interface

SIM8200G supports two 16bits ADC interfaces. Its performance parameters are shown as follow:

Table 38: Definition of ADC interface

Pin name	Pin no.	Electrical description	description	Comment
ADC0	AH7	AI	Analog to digital converter input0	
ADC1	AF7	AI	Analog to digital converter input1	

Table 39: ADC performance parameters

Parameter	Comments	Min	Typ	Max	Unit
Input voltage range	Programmable	0	-	1.875	V
Resolution		-	16	-	bits
Analog input bandwidth		-	500	-	KHz
Sample rate		-	4.8	-	MHz
Accuracy		-	20	-	mV

3.15 WLAN/BT Interface

SIM8200G supports W80 interface including PCIe, UART, GPIOs, and customers can connect to the W80 WLAN/BT module through this interface. The reference circuit is as follows:

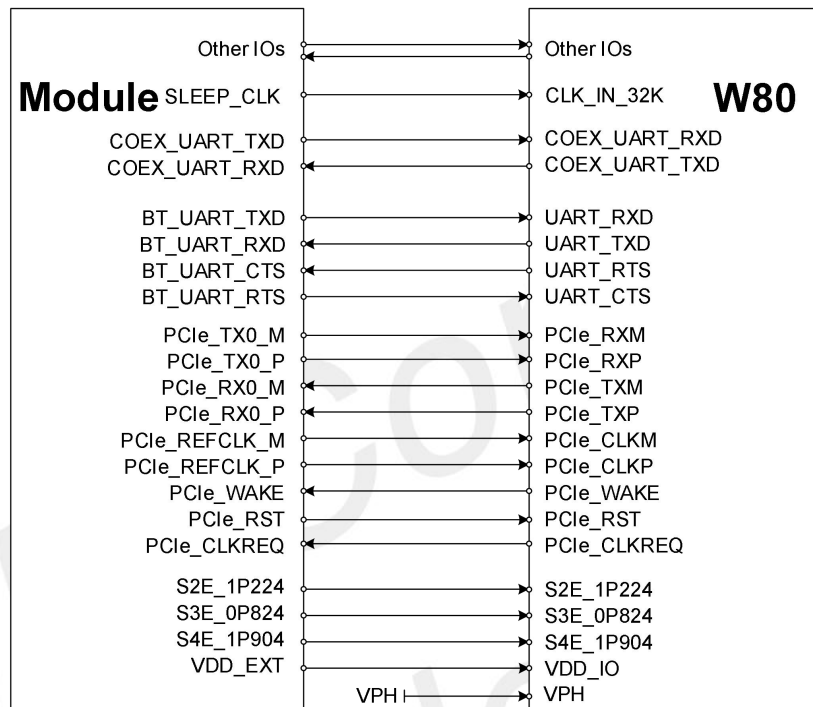

Figure 35: SIM8200G and W80 connect circuit

NOTE

1. Before powering on the module, please keep pin WL_TO_SD_X_CTI floating.

Table 40: Definition of WLAN/BT interface

Pin name	Pin no.	Electrical description	description	Comment
WL_SW_CTRL	K49	DO	W80 switch control	
SDX_TO_WL_CTI	M49	DO	W80 GPIO	
WL_TO_SD_X_CTI	L47	DI	W80 GPIO	Before powering on the module, please keep this pin floating.
BT_EN	N51	DO	W80 BT enable	
SLEEP_CLK	J51	DO	Sleep clock output for W80 only	
WL_EN	K45	DO	WLAN enable	
WL_LAA_RX	J47	DI	WLAN XFEM control for LAA	W80 RF coexistence

			receiver	signals
WL_PA_MUTI NG	H45	DO	WLAN XFEM control for PA mute	
WL_LAA_AS_ EN	L51	DO	WLAN LAA AS enable	
WL_LAA_TX_ EN	R51	DO	WLAN XFEM control for LAA enable	
COEX_UART_ TXD	BA7	DO	LTE&WLAN coexistence data transmit	
COEX_UART_ RXD	BA9	DI	LTE&WLAN coexistence data receive	
WL_TX_EN	AY14	DI	WLAN XFEM control for WLAN TX enable	

NOTE

WL_I2S cannot be used for W80 module.

W80 performance as follows, details please refer to the W80 hardware design.

- Compliant with IEEE 802.11a/b/g/n/ac/ax.
- Supports 2x2 Multi-User Multiple-Input Multiple-Output (MU-MIMO.)
- Dual band 2.4G/5G chains.
- Dynamic Frequency Selection (DFS, radar detection).
- Offloading traffic for minimal host utilization at 11ac/ax speeds.
- Low power PCIe interface.

3.16 PM8150B Interface

SIM8200G supports PM8150B interface, customers can use PM8150B to manage the charge out of the module. The reference circuits as follows:

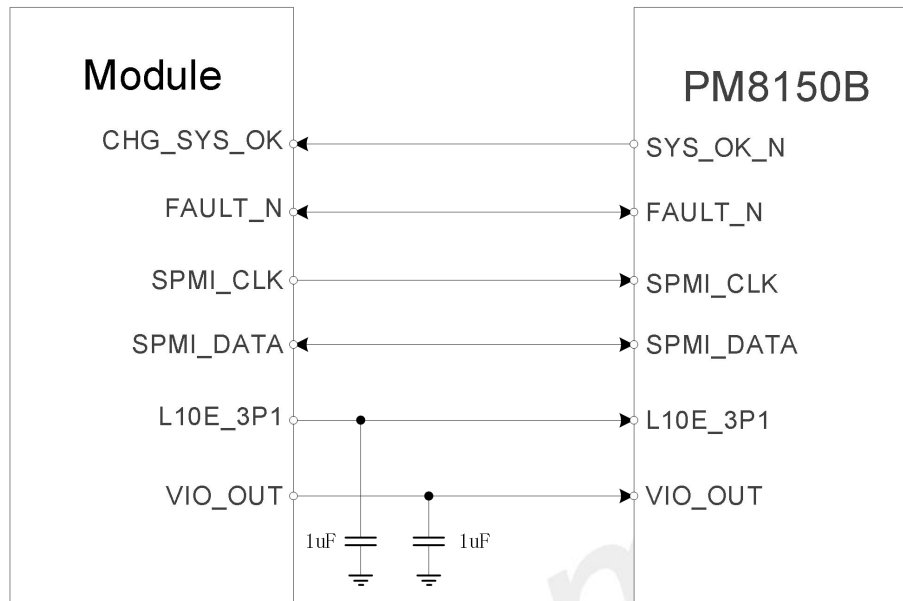

Figure 36: PM8150B interface diagram circuit

Table 41: Definition of PM8150B interface

Pin name	Pin no.	Pin characteristics	Functional description	Comment
CHG_SYS_OK	C43	DI	When charger input is inserted PM8150B output signal to PMU	Used for PM8150B only
FAULT_N	B44	DIO	Used to send/receive the fault condition across all PMICs in the chipset	
SPMI_CLK	A47	DO	SPMI communication bus clock signal	Required 50Ω impedance
SPMI_DATA	B46	DIO	SPMI communication bus data signal	
L10E_3P1	C41	PO	Output power supply for PM8150B USB PD-PHY and USB switch	Only used for PM8150B
VIO_OUT	D42	PO	Output power for PM8150B IO circuit	

PM8150B performance as follows: please refer to SIM8200G reference design for details

- Supports USB Type-C specification Rev. 1.3 and USB power delivery specification Rev. 3.0*.
- Supports Qualcomm Quick Charge 2.0, Quick Charge 3.0*, and Quick Charge 4.0* technology.

NOTE

1. “*” means under development.
2. Standard software not support PM8150B function.

SPMI interface layout guidelines:

- Require single-ended trace impedance is $45\Omega \pm 10\%$.
- CLK to DATA length mismatch is less than 0.5mm.
- Bus capacitance load is less than 10PF.
- Gap to other signals keeps 3xline width.
- Gap clock-to-data keeps 2xline width.
- Trace routes away from sensitive signals.
- Maximum PCB trace length can't exceed 50mm out of the module.

3.17 GPIOs Interface

The follow pins of SIM8200G can be used as GPIO function, if the customer does not use the default functions. In addition, these pins support alternate function by software configure according to the customer's requirements.

Table 42: GPIO list

PIN name	PIN no.	Default function	Alternate function 1	Interrupt function
UART2_TXD	U1	UART2_TXD	SPI_MOSI	
UART2_RXD	W1	UART2_RXD	SPI_MISO	✓
UART2_CTS	V3	UART2_CTS	SPI_CS_N	✓
UART2_RTS	Y3	UART2_RTS	SPI_CLK	
I2S_WS	T3	I2S_WS	PCM_SYNC	✓
I2S_DIN	R1	I2S_DIN	PCM_DIN	✓
I2S_DOUT	N1	I2S_DOUT	PCM_DOUT	✓
I2S_CLK	P3	I2S_SCK	PCM_CLK	✓
WL_I2S_WS	G1	WL_I2S_WS	SPI_MOS	✓
WL_I2S_DIN	M3	WL_I2S_DIN	SPI_MISO	✓
WL_I2S_DOUT	K3	WL_I2S_DOUT	SPI_CS_N	✓
WL_I2S_CLK	J1	WL_I2S_SCK	SPI_CLK	✓
BT_UART_RXD	V7	BT_UART_RX		✓
BT_UART_CTS	R5	BT_UART_CTS	I2C_SDA	✓
BT_UART_RTS	U5	BT_UART_RTS	I2C_SCL	
SPI_MOSI	D14	SPI_MOSI		
SPI_MISO	D16	SPI_MISO		
SPI_CS_N	D18	SPI_CS	I2C_SDA	
SPI_CLK	D20	SPI_CLK	I2C_SCL	✓
CDC_RST_N	AK7	CDC_RST_N		

CDC_INT_N

AM7

CDC_INT_N

✓

NOTE

1. “✓” means the GPIO support interrupt function.
2. All pins list in Table 37, GPIO default state is B-PD.

3.18 Network Status

The NET_STATUS pin is used to control network status LED, its reference circuit is shown in the following figure.

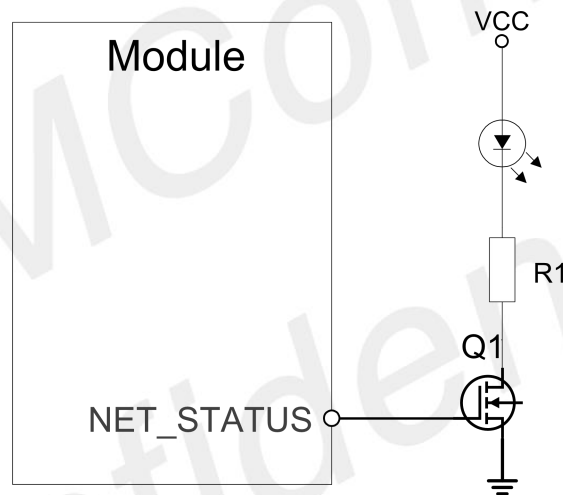

Figure 37: NET_STATUS reference circuit

Table 43: Definition of NET_STATUS pin

Pin Name	Pin No.	Electrical Description	Description	Comments
NET_STATUS	AE1	DO	Indicate network activity status of the module	

NOTE

3. The value of the resistor R1 depends on the LED characteristics.

The timing parameters are shown in the following table.

Table 44: NET_STATUS pin status

NET_STATUS pin status	Module status
Always On	Searching network; call connection(including 5G,VOLTE)
100ms ON, 100ms OFF	Data transmitting; 5G registered on network
200ms ON, 200ms OFF	Data transmitting; 4G registered on network
800ms ON, 800ms OFF	Data transmitting; 3G registered on network
OFF	Power off ; in sleep mode

3.19 Flight Mode Control

The W_DISABLE pin can be used to control SIM8200G to enter or exit the flight mode. In flight mode, the RF circuit is closed to prevent interference with other equipment's and minimize current consumption. Its reference circuit is shown in the following figure.

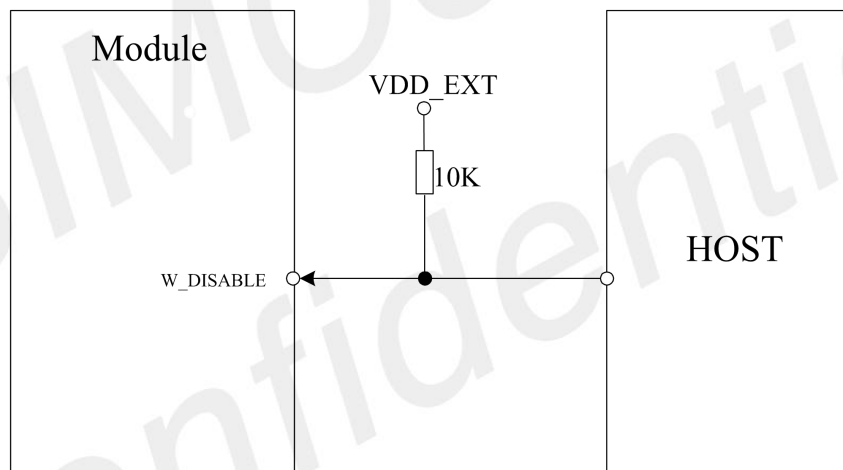

Figure 38: W_DISABLE pin reference circuit

Table 45: Definition of W_DISABLE pin

Pin Name	Pin No.	Electrical Description	Description	Comments
W_DISABLE	AG1	DI	Flight mode control input active low	

Table 46: W_DISABLE pin status

W_DISABLE pin status	Module operation
Input low level	Flight mode: RF is disabled
Input high level	AT+CFUN=4: Flight mode AT+CFUN=1: RF is enabled (Default)

3.20 TDD_SYNC_PPS

SIM8200G support TDD_SYNC_PPS signal, it can generate pulse use for indication NSA and SA sub6 the beginning frame flag of DL-UL, the pin level is 1.8V, customers can direct connect this pin to TDD synchronous input circuit.

Recommended reference circuit is shown in the following figure.

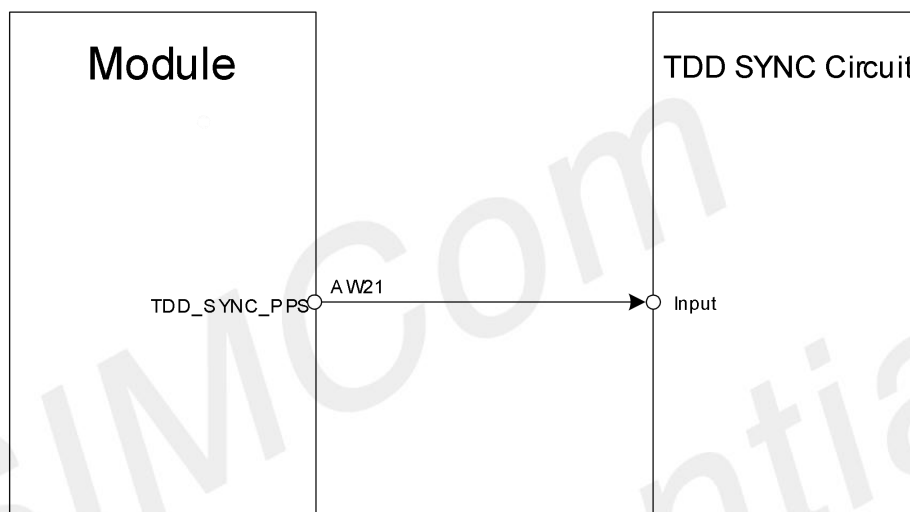

Figure 39: TDD_SYNC_PPS pin reference circuit

Table 47: Definition of TDD_SYNC_PPS pin

Pin name	Pin no.	Electrical description	Description	Comments
TDD_SYNC_PPS	AW21	DO	<ol style="list-style-type: none"> It can generate pulse use for indication NSA and SA sub6 the beginning frame flag of DL-UL The TDD_SYNC_PPS pin also can be configured GPS_1PPS signal output by software 	<p>1.8V voltage domain. S2-109WT supports this function</p> <p>The TDD_SYNC_PPS and GPS_1PPS function can't be used at the same time.</p>

NOTE

- S2-109WT supports this function.
- The TDD_SYNC_PPS pin also can be configured GPS_1PPS signal output by software, the TDD_SYNC_PPS and GPS_1PPS function can't be used at the same time.

The following is TDD_SYNC_PPS signal design guidelines:

- This signal trace should be treated as a data transmission line, required impedance is 50 Ω.
- This signal trace should as short as possible and cannot exceed 40mm out of the module.
- This signal trace should far away from RF, power and high-speed signals.
- This signal trace should be protected completely by GND.
- The rising slew rate is no poor than 3ns, falling slew rate is no poor than 5ns, even with default lowest drive strength (2mA) being selected.

3.21 Antenna Control Interface*

ANT_CTL[0:1] and RFFE0 signals are used for tunable antenna control and should be routed to an appropriate antenna control circuitry.

The following table are the definitions for antenn control interfaces.

Table 48: Definition of antenna control interface through GPIOs

Pin Name	Pin No.	Electrical Description	Description	Comments
RFFE0_CLK	BA11	DO	Antenna tuner MIPI CLK	
RFFE0_DATA	BA13	DIO	Antenna tuner MIPI DATA	1.8V voltage domain. If unused, please keep open
ANT_CTRL0	BA15	DO	Antenna tuner control0	
ANT_CTRL1	AY16	DO	Antenna tuner control1	

NOTE

1. "*" means under development, for details please contact SIMCom support teams.
2. The RFFE0 signals are multiplexed with ANTCTL2 and ANTCTL3.

4 Antenna Interfaces

SIM8200G provides eight antennas for 3G/4G/5G and GNSS. The antenna ports have an RF impedance of 50Ω.

4.1 Antenna Definitions

For detailed designs about antenna and if there is a requirement for minimum antennas, please refer to the antenna design guide “SIM8200G_LGA Antenna Port Mapping and Design Guide”.

Table 49: Antenna port definitions

FUNCTIONS			ANTENNAS									
			ANT0	ANT1	ANT2	ANT3	ANT4	ANT5	ANT6	ANT7		
3G/4G/5G	LB/MHB	TRX										
5G	n41	UL/DL-MIMO1	✓									
5G	n79	DL-MIMO2										
4G	MHB	DL-MIMO2										
4G	UHB	DIV		✓								
5G	n41/n77/n78	DIV										
3G/4G/5G	LB/MHB	DIV										
5G	n41	DL-MIMO2			✓							
5G	n79	UL/DL-MIMO1										
3G/4G/5G	MHB	DL-MIMO1										
4G	UHB	DL-MIMO2				✓						
5G	n77/n78	DL-MIMO2										
4G	UHB	DL-MIMO1										
5G	n41	TRX					✓					
5G	n77/n78	UL/DL-MIMO1										
5G	n77/n78	TRX							✓			
4G	UHB	TRX										
5G	n79	DIV								✓		
GNSS												
5G	n79	TRX										✓

4.1.1 3G/4G/5G Operating Frequency

Table 50: SIM8200G operating frequencies

Frequency band	Uplink (UL)	Downlink (DL)	Duplex mode
WCDMA B1	1920 MHz ~ 1980 MHz	2110 MHz ~ 2170 MHz	FDD
WCDMA B2	1850 MHz ~1910 MHz	1930 MHz ~ 1990 MHz	FDD
WCDMA B3	1710 MHz ~ 1785 MHz	1805 MHz ~ 1880 MHz	FDD
WCDMA B4	1710 MHz ~ 1755 MHz	2110 MHz ~ 2155 MHz	FDD
WCDMA B5	824 MHz ~ 849 MHz	869 MHz ~ 894MHz	FDD
WCDMA B8	880 MHz ~ 915 MHz	925 MHz ~ 960 MHz	FDD
LTE B1	1920 MHz ~ 1980 MHz	2110 MHz ~ 2170 MHz	FDD
LTE B2	1850 MHz ~ 1910MHz	1930 MHz ~ 1990MHz	FDD
LTE B3	1710 MHz ~ 1785 MHz	1805 MHz ~ 1880 MHz	FDD
LTE B4	1710 MHz ~ 1755MHz	2110 MHz ~ 2155MHz	FDD
LTE B5	824 MHz ~ 849 MHz	869 MHz ~ 894MHz	FDD
LTE B7	2500 MHz ~ 2570MHz	2620 MHz ~ 2690MHz	FDD
LTE B8	880 MHz ~ 915 MHz	925 MHz ~ 960 MHz	FDD
LTE B12	698 MHz ~ 716MHz	728 MHz ~ 746MHz	FDD
LTE B13	777 MHz ~787MHz	746 MHz ~ 756MHz	FDD
LTE B14	788 MHz ~ 798MHz	758 MHz ~ 768MHz	FDD
LTE B17	704 MHz ~ 716MHz	734 MHz ~ 746MHz	FDD
LTE B18	815 MHz ~ 830MHz	860 MHz ~ 875MHz	FDD
LTE B19	830 MHz ~ 845MHz	875 MHz ~ 890MHz	FDD
LTE B20	832 MHz ~ 862MHz	791 MHz ~ 821MHz	FDD
LTE B25	1850 MHz ~ 1915MHz	1930 MHz ~ 1995MHz	FDD
LTE B26	814 MHz ~849MHz	859 MHz ~ 894MHz	FDD
LTE B28	703 MHz ~ 748MHz	758 MHz ~ 803MHz	FDD
LTE B29	/	717 MHz ~ 728MHz	FDD
LTE B30	2305MHz ~ 2315MHz	2350 MHz ~ 2360MHz	FDD
LTE B32	/	1452 MHz ~ 1496MHz	FDD
LTE B34	2010 MHz ~ 2025MHz	2010 MHz ~ 2025MHz	TDD
LTE B38	2570 MHz ~ 2620 MHz	2570 MHz ~ 2620 MHz	TDD
LTE B39	1880 MHz ~ 1920MHz	1880 MHz ~ 1920MHz	TDD
LTE B40	2300 MHz ~ 2400 MHz	2300 MHz ~ 2400 MHz	TDD
LTE B41	2496 MHz ~ 2690 MHz	2496 MHz ~ 2690 MHz	TDD
LTE B42	3400MHz ~ 3600MHz	3400 MHz ~ 3600MHz	TDD
LTE B48	3550 MHz ~ 3700MHz	3550 MHz ~ 3700MHz	TDD
LTE B66	1710 MHz ~ 1780MHz	2110 MHz ~ 2180MHz	FDD
LTE B71	663 MHz ~ 698MHz	617MHz ~ 652MHz	FDD

NOTE

3. LTE-FDD B29 and B32 support Rx only and are only for secondary component carrier.

Table 51: NR band

Frequency band	Uplink (UL)	Downlink (DL)	Duplex mode
NR n1	1920MHz ~ 1980MHz	2110MHz ~ 2170MHz	FDD
NR n2	1850MHz ~ 1910MHz	1930MHz ~ 1990MHz	FDD
NR n3	1710MHz ~ 1785MHz	1805MHz ~ 1880MHz	FDD
NR n5	824MHz ~ 849MHz	869MHz ~ 894MHz	FDD
NR n7	2500MHz ~ 2570MHz	2620MHz ~ 2690MHz	FDD
NR n8	880MHz ~ 915 MHz	925MHz ~ 960 MHz	FDD
NR n12	699MHz ~ 716MHz	729MHz ~ 746MHz	FDD
NR n20	832MHz ~ 862MHz	791MHz ~ 821MHz	FDD
NR n25	1850MHz ~ 1915MHz	1930MHz ~ 1995MHz	FDD
NR n28	703MHz ~ 748MHz	758MHz ~ 803MHz	FDD
NR n40	2300MHz ~ 2400MHz	2300MHz ~ 2400MHz	TDD
NR n41	2496MHz ~ 2690MHz	2496MHz ~ 2690MHz	TDD
NR n66	1710MHz ~ 1780MHz	2110MHz ~ 2200MHz	FDD
NR n71	663MHz ~ 698MHz	617MHz ~ 652MHz	FDD
NR n77	3300MHz ~ 4200MHz	3300MHz ~ 4200MHz	TDD
NR n78	3300MHz ~ 3800MHz	3300MHz ~ 3800MHz	TDD
NR n79	4400MHz ~ 5000MHz	4400MHz ~ 5000MHz	TDD

4.1.2 GNSS Frequency

The following table shows frequency specification of GNSS antenna interface.

Table 52: GNSS frequency

Type	Frequency
GPS L1/Galileo/QZSS	1575.42±1.023MHz
GPS L5	1176.45±10.23MHz
GLONASS	1597.5~1605.8MHz
BeiDou/Compass	1561.098±2.046MHz

4.2 Antenna Installation

4.2.1 PCB Layout Guidelines

To avoid interference, minimize the insertion loss of the RF trace, the PCB should follow below rules:

- (1) The coaxial cable PCB pads, RF antenna connector and other connectors which used to test contact performance of module should place as close as to the module antenna pads.
- (2) The antenna matching network should place to antenna feed port.
- (3) The RF trace should be as short and straight as possible, and do not routing as perpendicular line, we recommend do it as 45° corner trace.
- (4) And the RF trace ground should be complete;
- (5) RF device should place ground to the nearest ground plane;
- (6) Between RF trace and below should avoid other signal trace or parallel trace to the RF signal.
- (7) Recommend to more ground vias near the RF traces.

4.2.2 Antenna Tuner

When end device need to support 700MHz low frequency(B12\B13\B28), it is recommended to add antenna tuner to improve RF performance. Antenna tuner contains antenna aperture tuner, antenna impedance tuner and hybrid tuner of the two. Aperture tuner optimizes the total antenna efficiency from the free space of the antenna terminal, and can optimize antenna efficiency across multiple frequency bands. Impedance tuner adjusts the mismatch between the RF front end and the antenna to achieve maximum transmission power. Hybrid tuner combines the advantages of both to maximize antenna RF performance. Customers can choose according to specific needs, according to the recommendations from the antenna vendor.

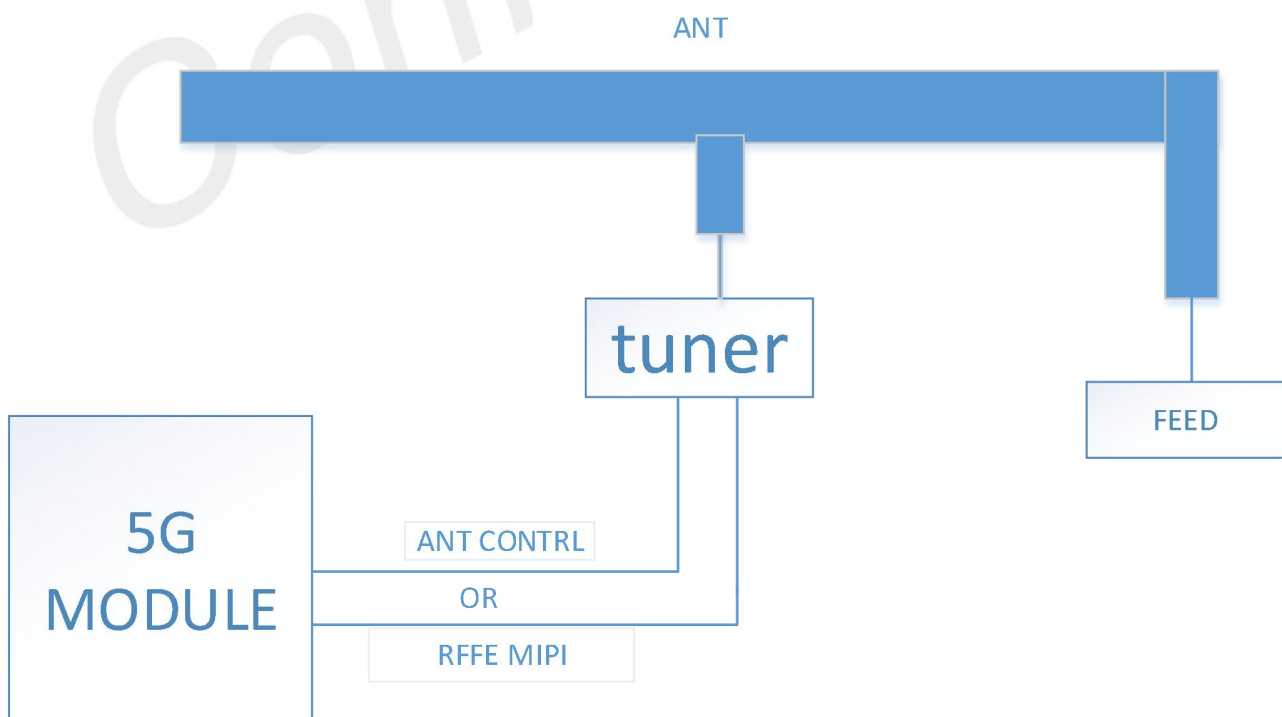

Figure 40: Aperture tuner reference block diagram

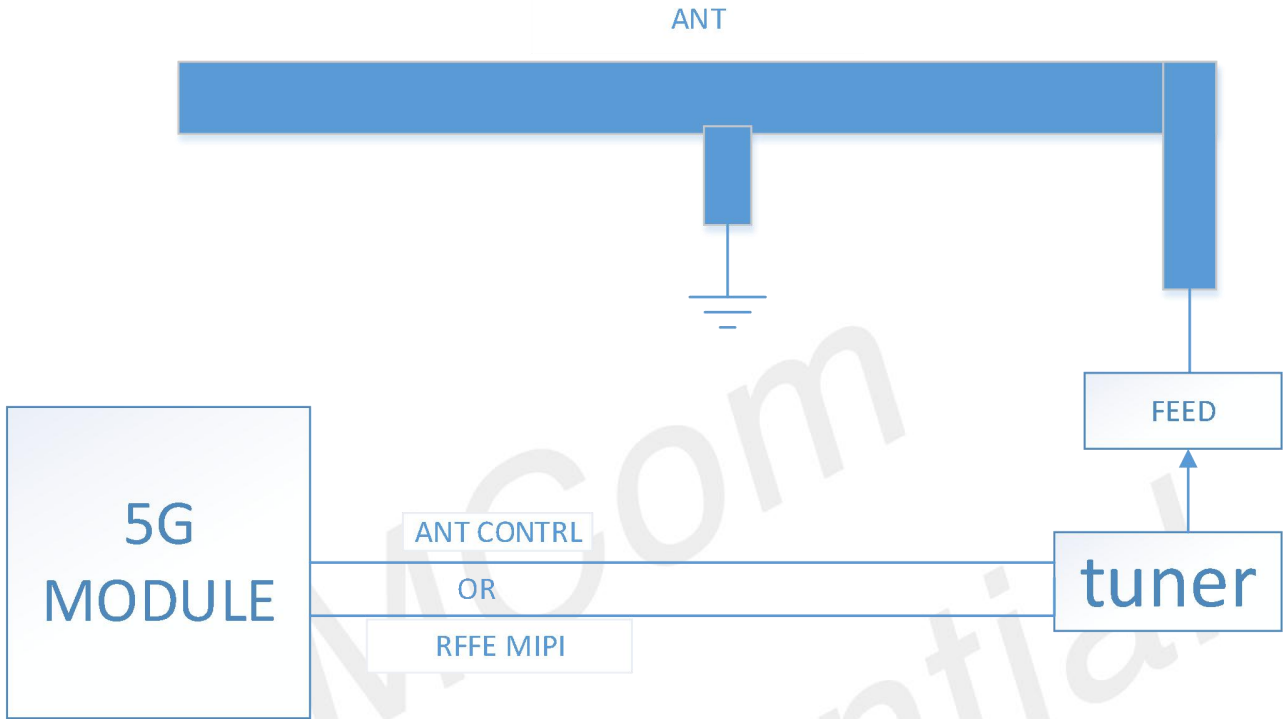

Figure 41: Impedance tuner reference block diagram

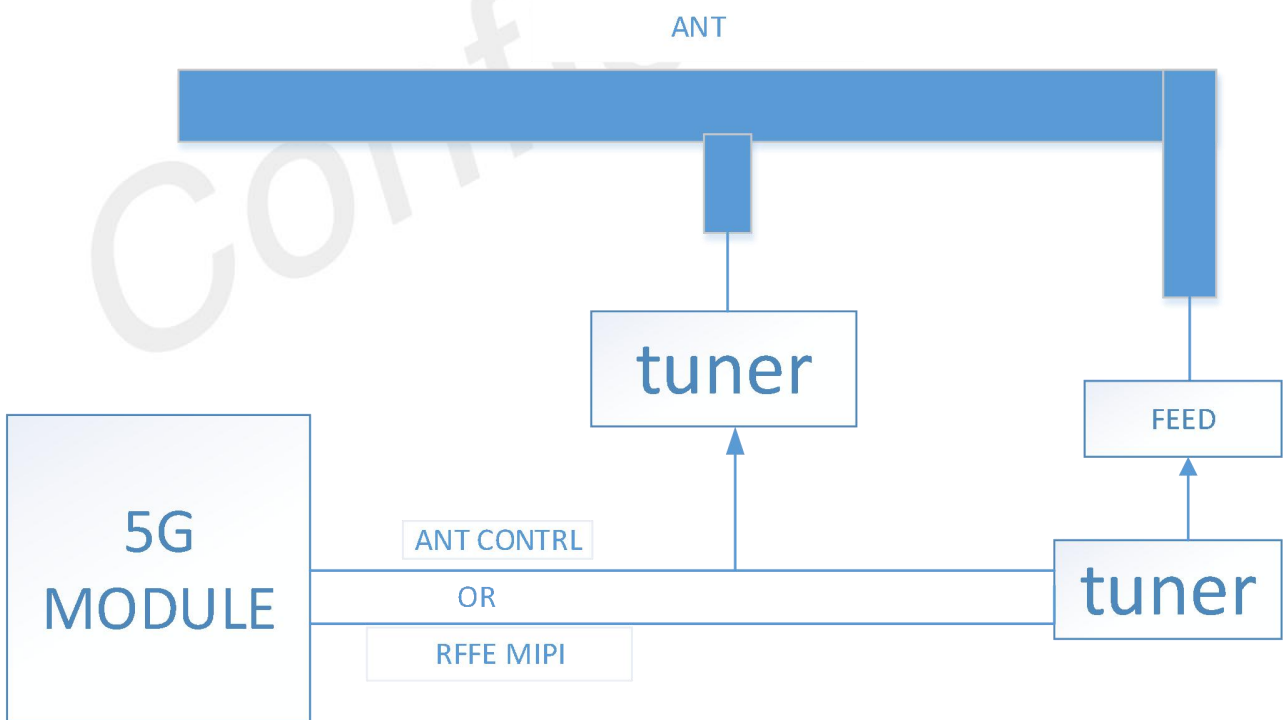

Figure 42: Hybrid tuner reference block diagram

The antenna control Tuner mipi interface of different package modules is as follows.

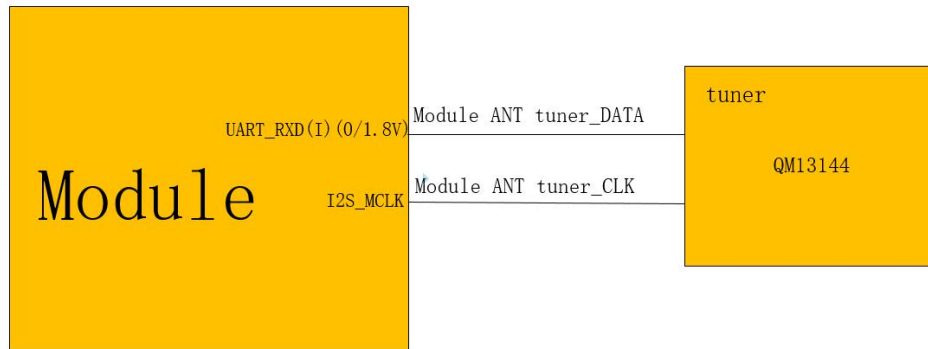

Figure 43: M.2 package Tuner mipi interface

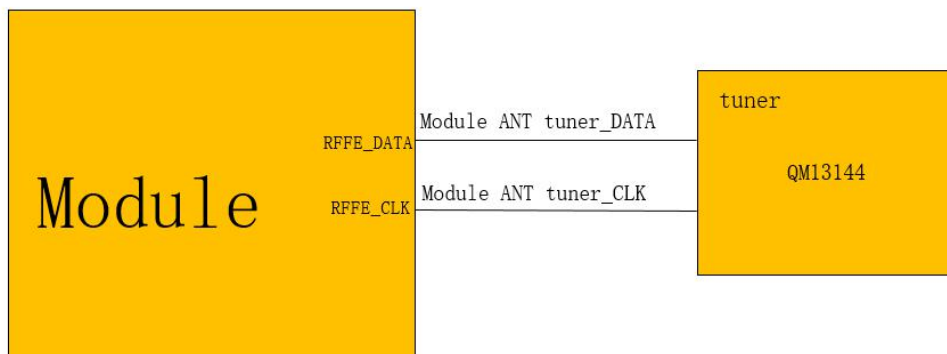

Figure 44: LGA package Tuner mipi interface

NOTE

1. When multiple Tuners are needed, pay attention to the distinction of the same device USID under the same group of mipi;
2. For details please refer to the Antenna Tuner Reference Design document and contact SIMCom support teams .

4.2.3 Antenna Requirements

The following table shows the requirements on 3G/4G/5G antennas and GNSS antenna.

Table 53: 3G/4G/5G/GNSS antennas

Parameter	Requirement
Operating Frequency	See Table 48 for each antenna
Direction	Omni Directional
Gain	> -3dBi (Avg)
Impedance	50 Ω
Efficiency	> 50 %
Max. Input Power	50W
VSWR	< 2
Isolation	20dB is preferred
Cable Insertion Loss <1GHz	<1dB
Cable Insertion Loss 1GHz~2.2GHz	<1.5dB
Cable Insertion Loss 2.3GHz~2.7GHz	<2dB
Cable Insertion Loss 3.3GHz~6GHz	<2.5dB

Table 54: GNSS antenna (for dedicated GNSS antenna only)*

Parameter	Requirement
Operating Frequency	L1: 1559~1609MHZ L5: 1166~1187MHZ
Direction	Hemisphere, face to sky
Antenna Gain	> 2 dB _{ic}
Impedance	50 Ω
Efficiency	> 50 %
Max. Input Power	50W
VSWR	< 2
Polarization	RHCP or Linear
Noise Figure for Active Antenna	< 1.5
Total Gain for Active Antenna	< 17 dB
Cable Insertion Loss	<1.5dB

NOTE

*: These recommendations are for dedicated GNSS antenna which the application need best of class GNSS tracking performance.

4.2.4 RF Plug Recommendation

SIM8200G is mounted with I-PEX's receptacle RF connectors 20449-001E-03, which size is 2.0mm*2.0mm*0.6mm. The connector dimensions are shown as below.

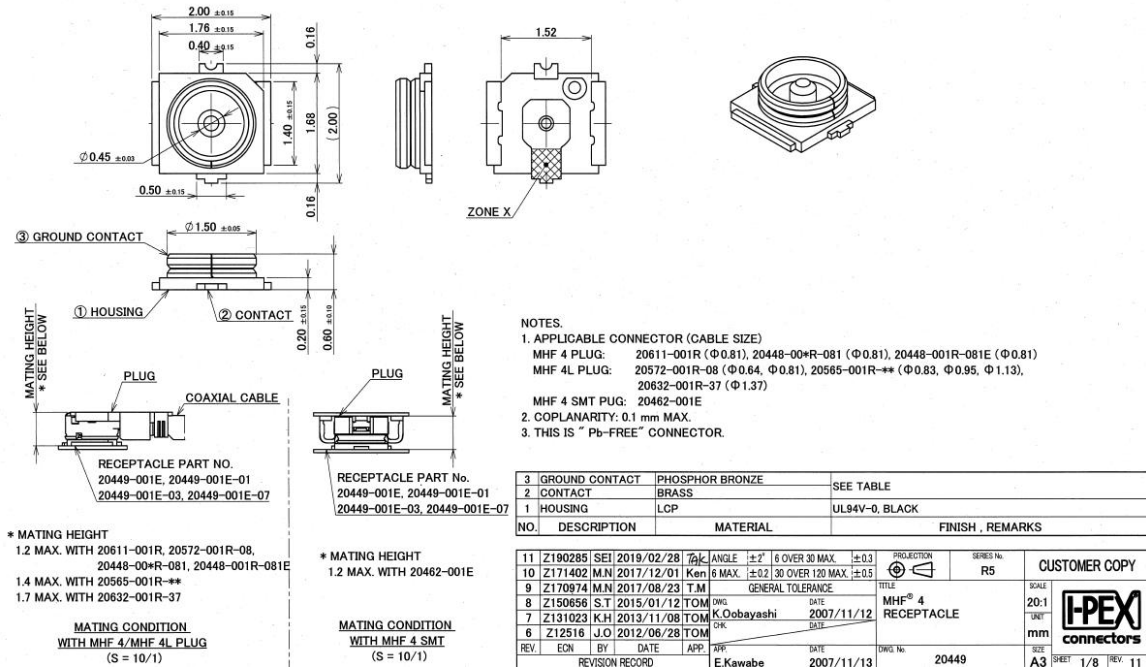

Figure 45: 3D view of 20449-001E-03

The following table shows the RF connector's electrical specifications.

Table 55: Electrical Specifications of 20449-001E-03

Item	Specification
Voltage Rating	60V r.m.s. maximum
Nominal Frequency Range	DC to 6GHz
Nominal Impedance	50Ω
Temperature Rating	-40°C to +90°C
Insulation Resistance	500 MΩ minimum
Withstanding Voltage	No evidence of breakdown
Initial Contact Resistance (without conductor resistance)	Center contact 20.0mΩmax. Outer contact 20.0mΩmax.
Voltage Standing Wave Ratio (V.S.W.R.)	Meet the requirements of 1.3max.(DC~3GHz) 1.45max.(3GHz~6GHz)

To get best RF performance, the RF plug connector should be designed to match the receptacle 20449-001E-03, and the parts come from I-PEX is the recommended.

The following is the mechanical information of the I-PEX's RF coaxial cable GLJ-RH120-1901 for reference. For further technical support, the customer could visit the I-PEX's website or contact the local

5 Electrical Specifications

5.1 Absolute Maximum Ratings

Absolute maximum rating for digital and analog pins of module are listed in the following table:

Table 56: Absolute maximum ratings

Parameter	Min.	Typ.	Max.	Unit
Voltage at VBAT ¹ pins	-	-	4.8	V
Voltage at USB_VBUS	-	-	6	V
Voltage at PWRKEY	-	-	2.1	V
Voltage at RESIN_N	-	-	1.9	V
Voltage at digital pins (GPIO,I2C,UART, I2S)	-	-	2.1	V
Voltage at digital pins (U)SIM	-	-	3.05	V

NOTE

3. The VBAT include VBAT_BB and VBAT_RF pins.

5.2 Operating Conditions

Table 57: VBAT recommended operating ratings

Parameter	Min.	Typ.	Max.	Unit
Voltage at VBAT ¹ pins	3.3	3.8	4.4	V

NOTE

3. The VBAT include VBAT_BB and VBAT_RF pins.

Table 58: 1.8V digital I/O characteristics

Parameter	Description	Min.	Typ.	Max.	Unit
V _{IH}	High-level input voltage	1.17	-	2.1	V
V _{IL}	Low-level input voltage	0	-	0.63	V
V _{OH}	High-level output voltage	1.35	-	1.8	V
V _{OL}	Low-level output voltage	0	-	0.45	V
I _{OZH}	High-level, tri-state leakage current (no pull down resistor)	-	-	1	uA
I _{OZL}	Low-level, tri-state leakage current (no pull up resistor)	-1	-	-	uA
I _{IH}	Input high leakage current (no pull down resistor)	-	-	1	uA
I _{IL}	Input low leakage current(no pull up resistor)	-1	-	-	uA

NOTE

These parameters are for digital interface pins, such as UART, I2C, I2S, SPI, and GPIOs (SIM_DET, SD_DET).

Table 59: Operating temperature

Parameter	Min.	Typ.	Max.	Unit
Normal operation temperature(3GPP compliant)	-30	-	70	°C
Extended operation temperature	-40	-	85	°C
Storage temperature	-40	-	90	°C

5.3 Operating Mode

5.3.1 Operating Mode Definition

The table below summarizes the various operating modes of module.

Table 60: Operating mode definition

Mode	Function
Normal operation	UMTS/LTE/5G
Sleep	AT command "AT+CSCLK=1" can be used to set the module to a sleep mode. In this case, the current consumption of module will be reduced

		to a very low level and the module can still receive paging message and SMS.
	UMTS/LTE/5G Idle	Software is active. Module is registered to the network and ready to communicate.
	UMTS/LTE/5G Talk	Connection between two subscribers is in progress. In this case, the power consumption depends on network settings such as DTX off/on, FR/EFR/HR, hopping sequences and antenna.
	UMTS/LTE/5G Standby	Module is ready for data transmission, but no data is currently sent or received. In this case, power consumption depends on network settings.
	UMTS/LTE/5G Data transmission	There is data transmission in progress. In this case, power consumption is related to network settings (e.g. power control level); uplink/downlink data rates, etc.
Minimum functionality mode		AT command "AT+CFUN=0" can be used to set the Module to a minimum functionality mode without removing the power supply. In this mode, the RF part of the Module will not work and the (U)SIM card will not be accessible, but the serial port and USB port are still accessible. The power consumption in this mode is lower than normal mode.
Flight mode		AT command "AT+CFUN=4" or pulling down the W_disable1# pin can be used to set the Module to flight mode without removing the power supply. In this mode, the RF part of the Module will not work, but the serial port and USB port are still accessible. The power consumption in this mode is lower than normal mode.
Power off		Normally module will go into power off mode by sending the AT command "AT+CPOF" or pull down the FUL_CARD_POWER_OFF# pin. In this mode the power management unit shuts down the power supply, and software is not active. The serial port and USB are is not accessible.

5.3.2 Sleep Mode

In sleep mode, the current consumption of module will be reduced to a very low level.

Several hardware and software conditions must be satisfied in order to let module enter into sleep mode:

1. UART condition
2. USB condition
3. Software condition

NOTE

Before designing, pay attention to how to realize sleeping/waking function.

5.3.3 Minimum Functionality Mode and Flight Mode

Minimum functionality mode ceases a majority function of Module, in order to minimizing the power consumption. This mode is set by the AT command which provides a choice of 3 different functionality levels.

- AT+CFUN=0: Minimum functionality
- AT+CFUN=1: Full functionality (Default)
- AT+CFUN=4: Flight mode

If module has been set to minimum functionality mode, the RF (U)SIM card function will be closed while the serial port and USB are still available.

If module has been set to flight mode, the RF function will be closed, while the (U)SIM card , the serial port and USB are still available.

When module is in minimum functionality or flight mode, it can return to full functionality by the AT command "AT+CFUN=1".

5.4 Current Consumption

The current consumptions are listed in the follows table.

Table 61: Current consumption on VBAT pins (VBAT=3.8V)

Description	Condition.	Typical	Unit
Power off mode	Power off	28	uA
GNSS mode	DPO	19	mA
Sleep mode (GNSS off, without connection USB)	WCDMA(AT+CFUN=0)	1.0	mA
	WCDMA DRX=1.28s	1.6	mA
	WCDMA DRX=2.56s	1.6	mA
	LTE-FDD(AT+CFUN=0)	1.0	mA
	LTE-FDD DRX=0.32s	3.3	mA
	LTE-FDD DRX=0.64s	2.9	mA
	LTE-FDD DRX=1.28s	2.0	mA
	LTE-FDD DRX=2.56s	1.9	mA
	LTE-TDD(AT+CFUN=0)	1.0	mA
	LTE-TDD DRX=0.32s	3.3	mA
	LTE-TDD DRX=0.64s	2.9	mA
	LTE-TDD DRX=1.28s	2.0	mA
	LTE-TDD DRX=2.56s	1.3	mA
5G SA		TBD	mA

Idle mode (GNSS off, without connection USB)	WCDMA	16.3	mA
	LTE FDD	17.8	mA
	LTE TDD	18.4	mA
	5G SA	33.1	mA

HSDPA data

WCDMA B1	@Power 23.76dBm Typical: 834mA
WCDMA B2	@Power 24.00dBm Typical: 777mA
WCDMA B3	@Power 23.07dBm Typical: 816mA
WCDMA B4	@Power 22.28dBm Typical: 805mA
WCDMA B5	@Power 23.05dBm Typical: 466mA
WCDMA B8	@Power 24.58dBm Typical: 568mA

LTE data

LTE-FDD B1	@5MHz 22.72dBm Typical :797mA
	@10MHz 22.78dBm Typical :804mA
	@20MHz 22.62dBm Typical :794mA
LTE-FDD B2	@5MHz 21.31dBm Typical :686mA
	@10MHz 21.25dBm Typical :733mA
	@20MHz 21.32dBm Typical :709mA
LTE-FDD B3	@5MHz 22.52dBm Typical :829mA
	@10MHz 22.48dBm Typical :844mA
	@20MHz 22.95dBm Typical :832mA
LTE-FDD B4	@5MHz 23.12dBm Typical :681mA
	@10MHz 23.19dBm Typical :706mA
	@20MHz 22.81dBm Typical :740mA
LTE-FDD B5	@5MHz 21.31dBm Typical :439mA
	@10MHz 21.18dBm Typical :439mA
LTE-FDD B7	@5MHz 23.38dBm Typical :733mA
	@10MHz 23.95dBm Typical :768mA
	@20MHz 23.92dBm Typical :791mA
LTE-FDD B8	@5MHz 22.27dBm Typical :506mA
	@10MHz 21.74dBm Typical :471mA
LTE-FDD B12	@5MHz 21.07dBm Typical :449mA
	@10MHz 21.09dBm Typical :447mA
LTE-FDD B13	@5MHz 20.70dBm Typical :464mA
	@10MHz 20.60dBm Typical :463mA
LTE-FDD B14	@5MHz 20.89dBm Typical :434mA
	@10MHz 21.05dBm Typical :447mA
LTE-FDD B17	@5MHz 21.04dBm Typical :448mA
	@10MHz 21.00dBm Typical :453mA
LTE-FDD B18	@5MHz 21.19dBm Typical :465mA
	@10MHz 21.32dBm Typical :471mA
LTE-FDD B19	@5MHz 21.14dBm Typical :457mA
	@10MHz 21.16dBm Typical :457mA
LTE-FDD B20	@5MHz 21.10dBm Typical :408mA
	@10MHz 21.00dBm Typical :403mA
	@20MHz 20.91dBm Typical :438mA
LTE-FDD B25	@5MHz 21.39dBm Typical :708mA
	@10MHz 21.46dBm Typical :754mA
	@20MHz 21.38dBm Typical :740mA
LTE-FDD B26	@5MHz 22.76dBm Typical :482mA
	@10MHz 22.63dBm Typical :483mA
LTE-FDD B28	@5MHz 23.33dBm Typical :556mA
	@10MHz 23.17dBm Typical :544mA
	@20MHz 23.16dBm Typical :536mA
LTE-FDD B30	@5MHz 22.92dBm Typical :784mA
	@10MHz 22.95dBm Typical :832mA
LTE-TDD B34	@5MHz 23.37dBm Typical :478mA
	@10MHz 23.52dBm Typical :513mA
LTE-TDD B38	@5MHz 22.41dBm Typical :704mA
	@10MHz 22.46dBm Typical :681mA

	@20MHz	22.35dBm	Typical :683mA
LTE-TDD B39	@5MHz	22.63dBm	Typical :575mA
	@10MHz	22.64dBm	Typical :586mA
	@20MHz	22.58dBm	Typical :607mA
LTE-TDD B40	@5MHz	23.08dBm	Typical :604mA
	@10MHz	23.01dBm	Typical :626mA
	@20MHz	23.09dBm	Typical :638mA
LTE-TDD B41	@5MHz	22.63dBm	Typical :634mA
	@10MHz	22.59dBm	Typical :644mA
	@20MHz	22.49dBm	Typical :652mA
LTE-TDD B42	@5MHz	22.33dBm	Typical :711mA
	@10MHz	22.30dBm	Typical :753mA
	@20MHz	22.16dBm	Typical :728mA
LTE-TDD B48	@5MHz	21.17dBm	Typical :739mA
	@10MHz	20.93dBm	Typical :742mA
	@20MHz	20.86dBm	Typical :742mA
LTE-FDD B66	@5MHz	22.43dBm	Typical :671mA
	@10MHz	22.39dBm	Typical :675mA
	@20MHz	22.23dBm	Typical :694mA
LTE-TDD B71	@5MHz	21.58dBm	Typical :515mA
	@10MHz	21.50dBm	Typical :486mA
	@20MHz	21.55dBm	Typical :475mA

5G NR data

5G n1	@Power	23dBm	Typical: TBD
5G n2	@Power	23dBm	Typical: TBD
5G n3	@Power	23dBm	Typical: TBD
5G n5	@Power	23dBm	Typical: TBD
5G n7	@Power	23dBm	Typical: TBD
5G n8	@Power	23dBm	Typical: TBD
5G n12	@Power	23dBm	Typical: TBD
5G n20	@Power	23dBm	Typical: TBD
5G n25	@Power	23dBm	Typical: TBD
5G n28	@Power	23dBm	Typical: TBD
5G n40	@Power	23dBm	Typical: TBD
5G n41	@60MHz	23.75dBm	Typical: 1087mA (Subcarrier spacing:30KHz)
5G n66	@Power	23dBm	Typical: TBD
5G n71	@Power	23dBm	Typical: TBD
5G n77	@Power	23dBm	Typical: TBD
5G n78	@100MHz	23.04dBm	Typical: 1073mA (Subcarrier spacing:30KHz)
5G n79	@100MHz	23.70dBm	Typical: 1136mA (Subcarrier spacing:30KHz)

NOTE

1. The VBAT include VBAT_BB and VBAT_RF pins.
2. The current consumption of table56 only for reference, please refer to actual current consumption.

5.5 RF Output Power

The RF output power is shown in the following table.

Table 62: Conducted output power

Frequency	Max	Min
WCDMA Bands	24dBm + 1/-3dB	< -50dBm
LTE-FDD Bands	23dBm + 2/-2dB	< -40dBm
LTE-TDD Bands	23dBm + 2/-2dB	< -40dBm
NR Bands	23dBm + 2/-3dB	< -40dBm
NR Bands(n41/n77/n78/n79)	26dBm + 2/-3dB	< -40dBm

5.6 Conducted Receive Sensitivity

SIM8200G conducted RF receiving sensitivity is fully meet 3GPP specification. Customers can get more details by check 3GPP official website <http://www.3gpp.org/>.

5.7 Thermal Design

Make sure that the SIM8200G can reach maximum work performance under extended temperature or extreme conditions for a long time, thermal dissipation design is very important.

There are some design rules to enhance thermal dissipation performance:

- Keep the module away from other heat sources such as battery, power, AP, etc.
- All the GND pins of the module should be connected.
- Add enough through GND via on the main PCB. Via material is very important solid copper and stacked via is better.
- Make sure maximize airflow around the module.
- Recommend use heat dissipation material connect to the customers' device on the top side of the module to enhance the heat dissipation. Large heat dissipation area is better.
- Chose a high effective heat dissipation material is better such as heat pipe, graphite sheets.

5.8 ESD

Module is sensitive to ESD in the process of storage, transporting, and assembling. When module is mounted on the customers' main board, the ESD components should be placed closed to the connectors which human body may touch, such as (U)SIM card socket, SD card socket, audio jacks, switches, USB interface, etc. The following table shows the module ESD measurement performance.

Table 63: The ESD performance measurement table (temperature: 25°C, humidity: 45%)

Part	Contact discharge	Air discharge
VBAT,GND	± 5kV	± 10 kV
Antenna	± 5 kV	± 10 kV
PWRKEY	± 4 kV	± 8 kV
USB	± 4 kV	± 8 kV
RESET_N	± 3 kV	± 6 kV
(U)SIM	± 3 kV	± 6 kV
Other PADS	±3 kV	±6 kV

NOTE

Test conditions:

1. The external of the module has surge protection diodes and ESD protection diodes.
2. The data in Table 56 were tested using SIMCom EVB.

6 Manufacturing

6.1 Top and Bottom View of SIM8200G

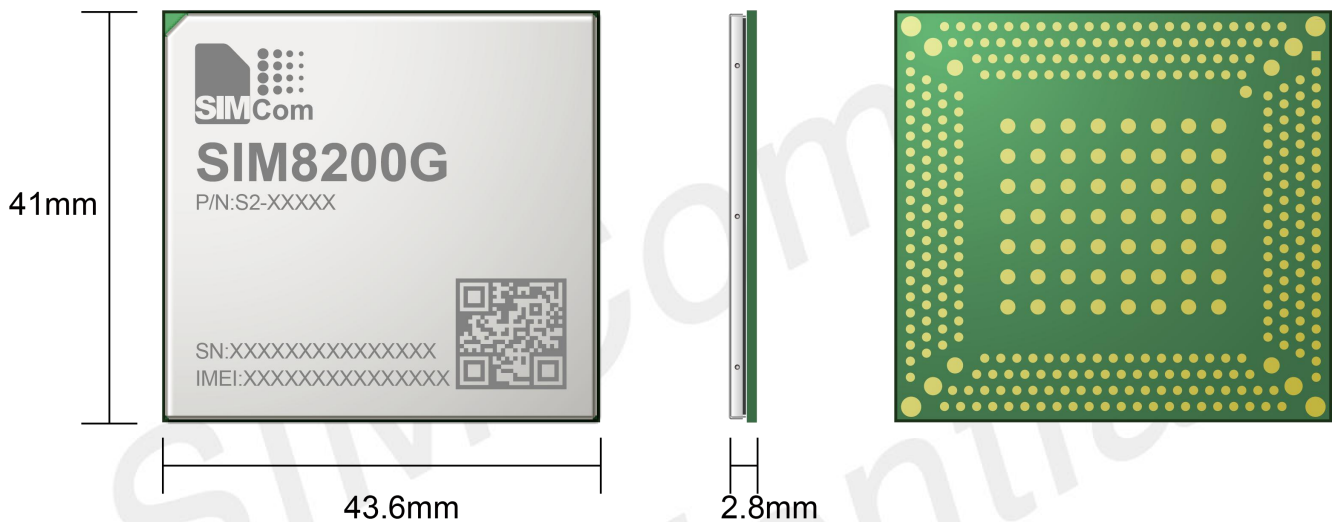

Figure 47: Top and bottom view of SIM8200G

6.2 Label Description Information

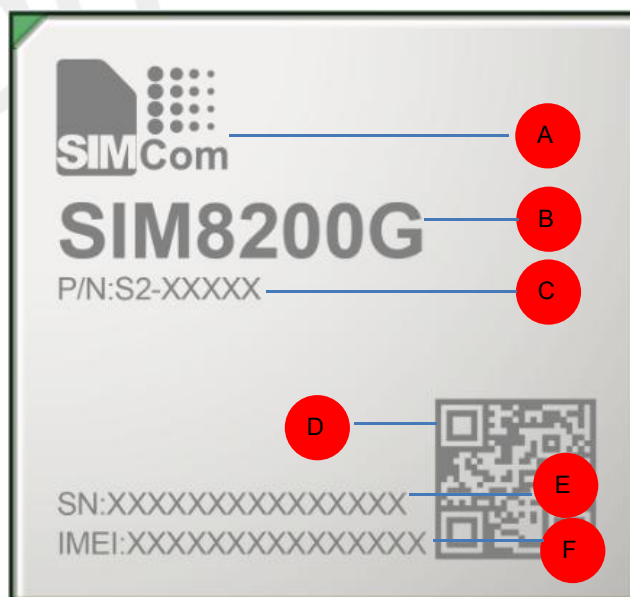

Figure 48: Label description of module

Table 64: Label description of module information

No.	Description
A	LOGO
B	Project name
C	Product code
D	QR code
E	Serial number
F	International mobile equipment identity

NOTE

Figure 35 and Figure 36 are the effect diagrams of the module, for reference only. Please refer to the actual product for appearance.

SIMCom
Confidential

6.3 Recommended PCB Footprint

The following figure shows the PCB footprint of SIM8200G.

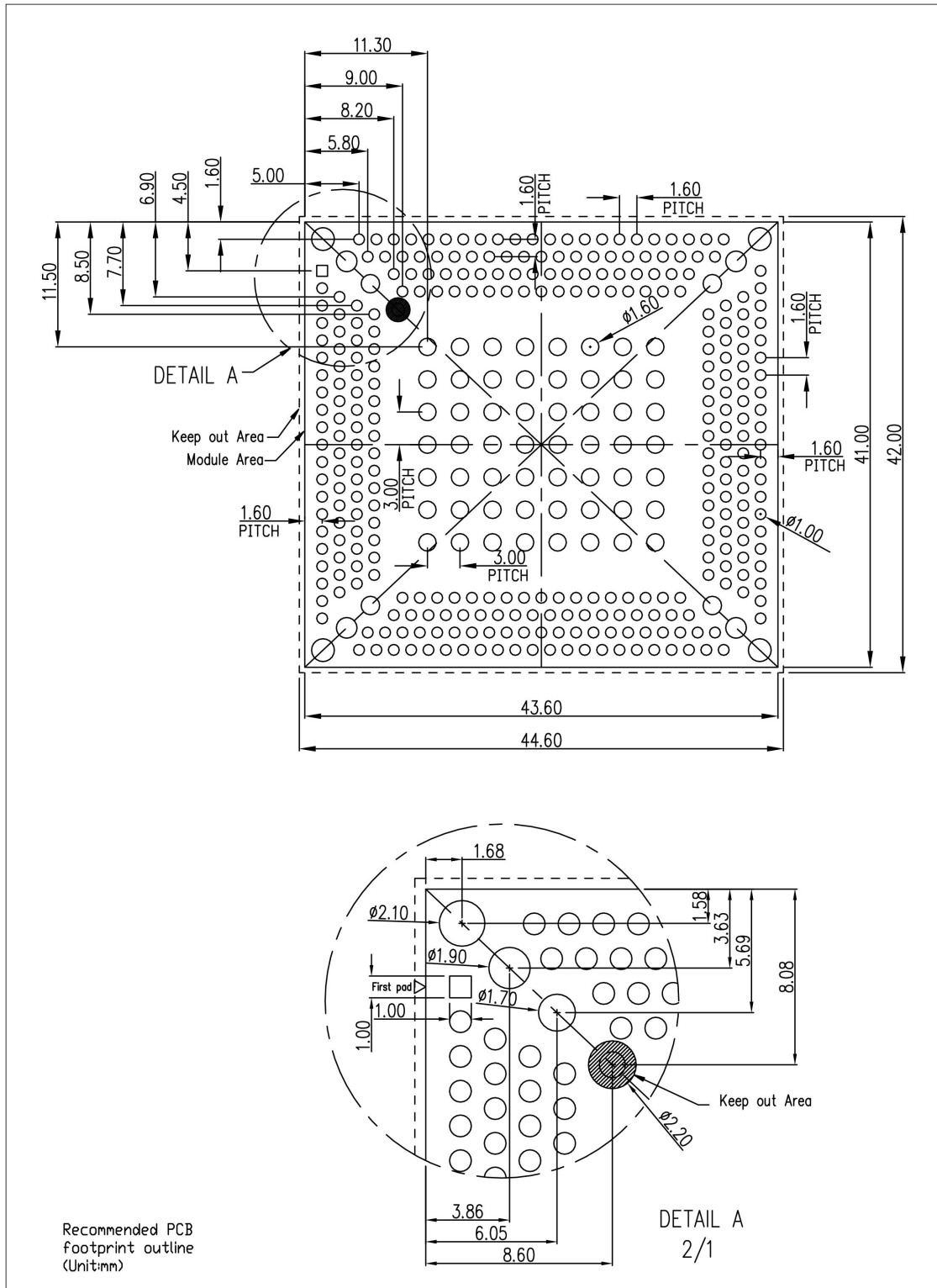

Figure 49: Recommended PCB footprint

6.4 Recommended SMT Stencil

The following figure shows the SMT stencil of SIM8200G.

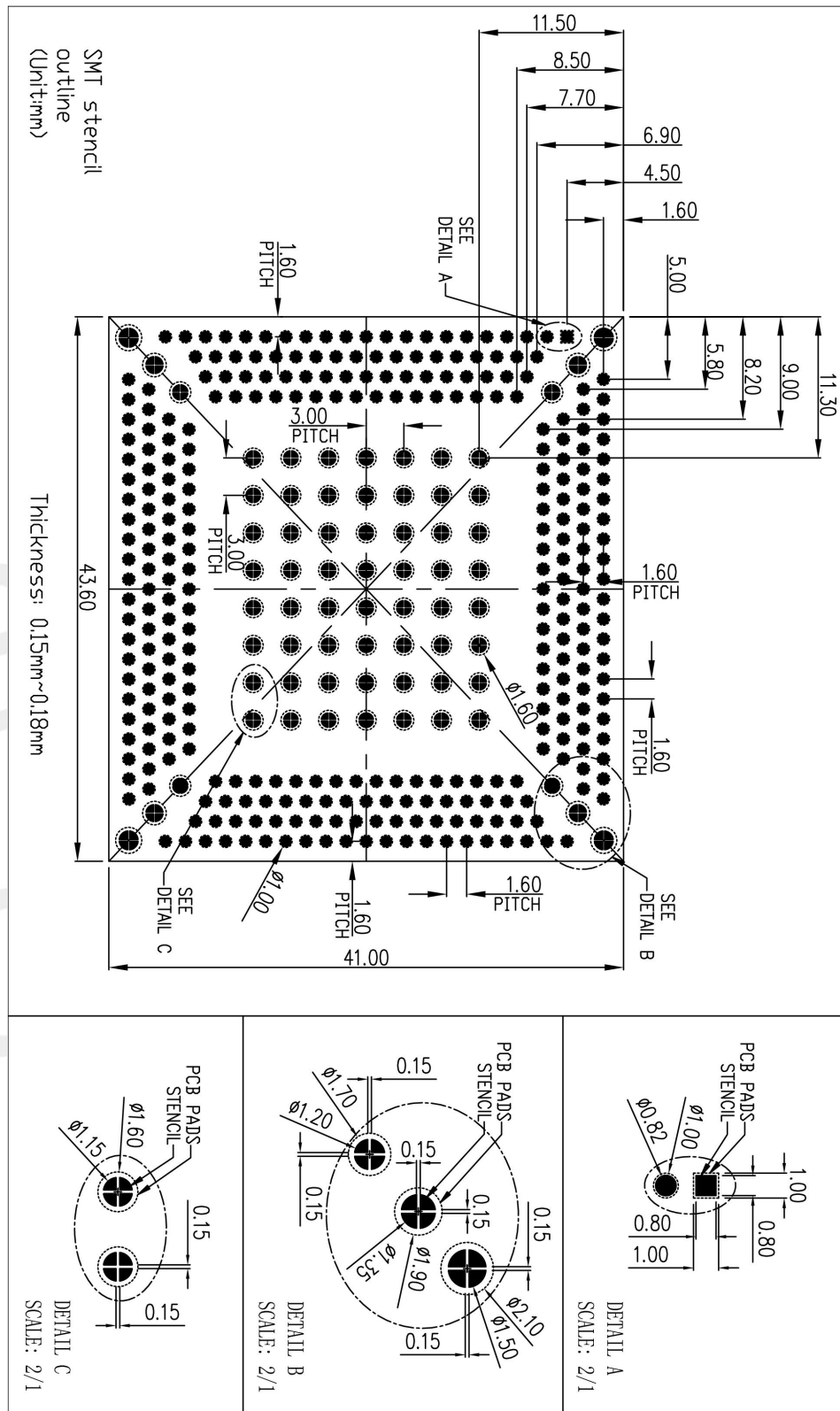

Figure 50: Recommended SMT stencil

6.5 Recommended SMT Reflow Profile

The following figure shows the SMT reflow profile of SIM8200G.

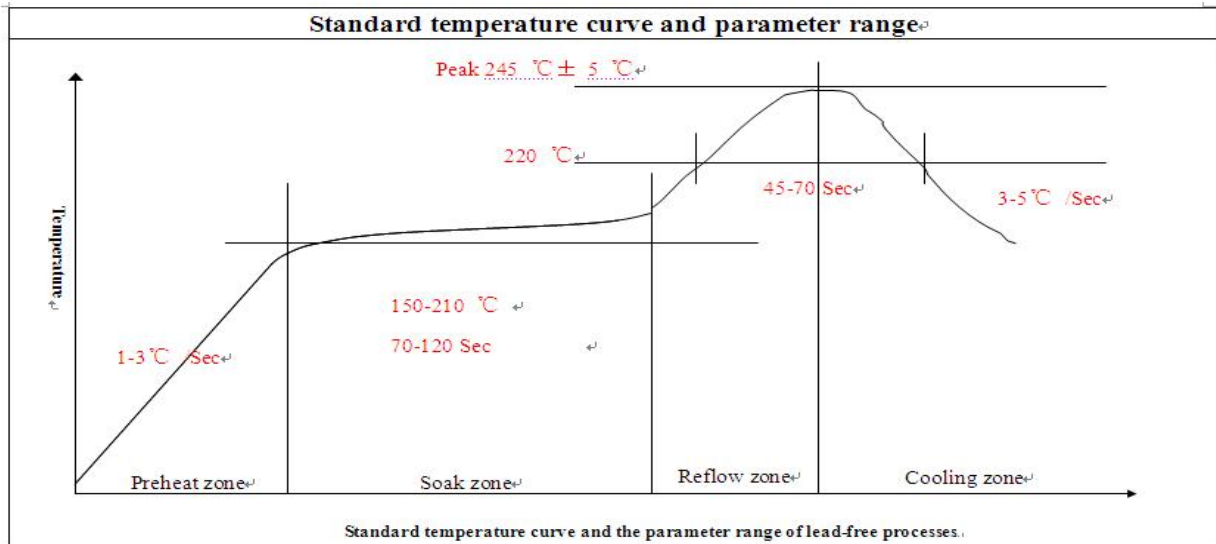

Figure 51: Recommended SMT reflow profile

NOTE

Refer to “Module secondary-SMT-UGD” for more information about the module shipping and manufacturing.

6.6 Moisture Sensitivity Level (MSL)

SIM8200G is susceptible to damage induced by absorbed moisture and high temperature. A package's moisture-sensitivity level (MSL) indicates its ability to withstand exposure after it is removed from its shipment bag, while it is on the factory floor awaiting PCB installation. A low MSL rating is better than a high rating; a low MSL device can be exposed on the factory floor longer than a high MSL device. All pertinent MSL ratings are summarized in Table 54.

Table 65: MSL ratings summary

MSL	Out-of-bag floor life	Comments
1	Unlimited	≤+30°C/85% RH
2	1 year	≤+30°C/60% RH
2a	4 weeks	≤+30°C/60% RH
3	168 hours	≤+30°C/60% RH
4	72 hours	≤+30°C/60% RH
5	48 hours	≤+30°C/60% RH
5a	24 hours	≤+30°C/60% RH
6	Mandatory bake before use. After bake, it must be reflowed within the time limit specified on the label.	≤+30°C/60% RH

The SIM8200G device samples are currently classified as MSL3 at 255 (+5, -0)°C, following the latest IPC/JEDEC J-STD-020 standard revision for moisture-sensitivity qualification. This qualification temperature (255°C) should not be confused with the peak temperature within the recommended solder reflow profile.

6.7 Baking Requirements

It is necessary to bake modules if the prescribed time limit has been exceeded. The baking conditions are specified in table 59. Note that if baking is required, the devices must be transferred into trays that can be baked to at least 125°C.

Table 66: Baking requirements

Baking conditions options	Duration
40°C±5°C, <5% RH	192 hours
120°C±5°C, <5% RH	4 hours

7 Packaging

SIM8200G module supports tray packaging. The packaging process is shown in the following figures.

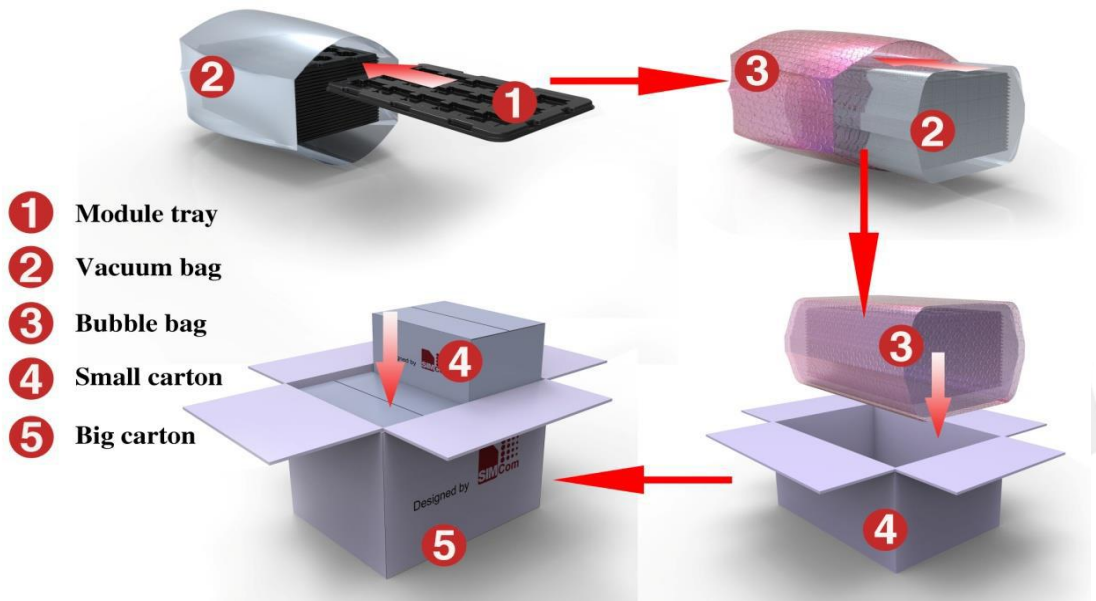

Figure 52: Packaging process

Module tray drawing:

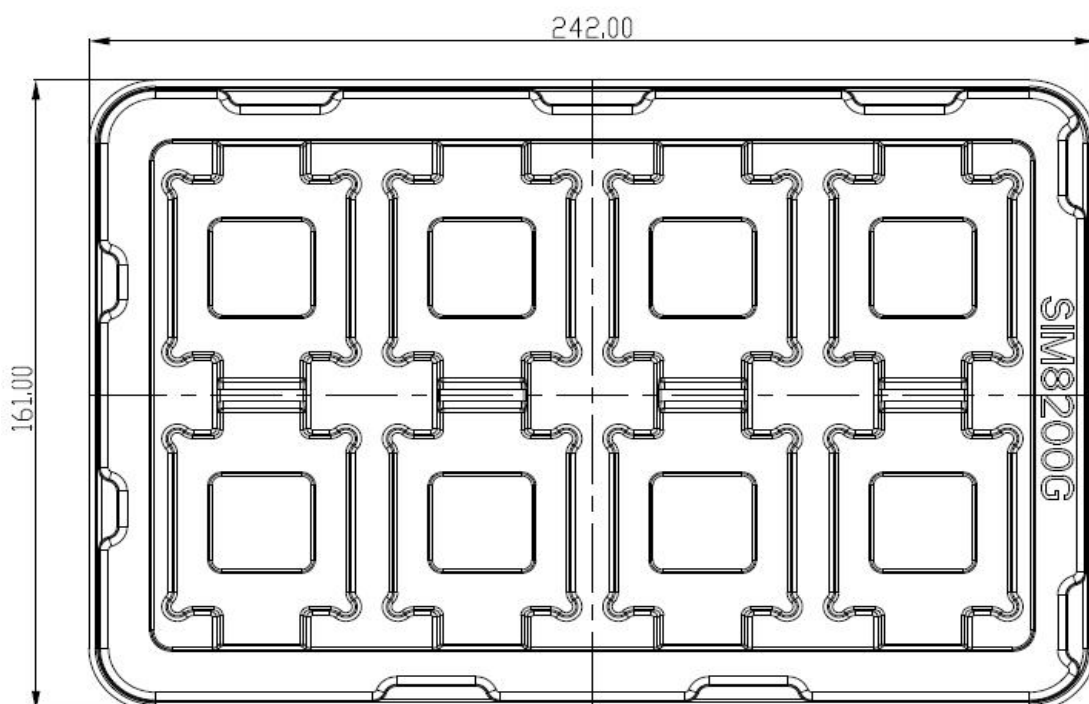

Figure 53: Module tray drawing

Table 67: Tray size

Length ($\pm 3\text{mm}$)	Width ($\pm 3\text{mm}$)	Number
242.0	161.0	8

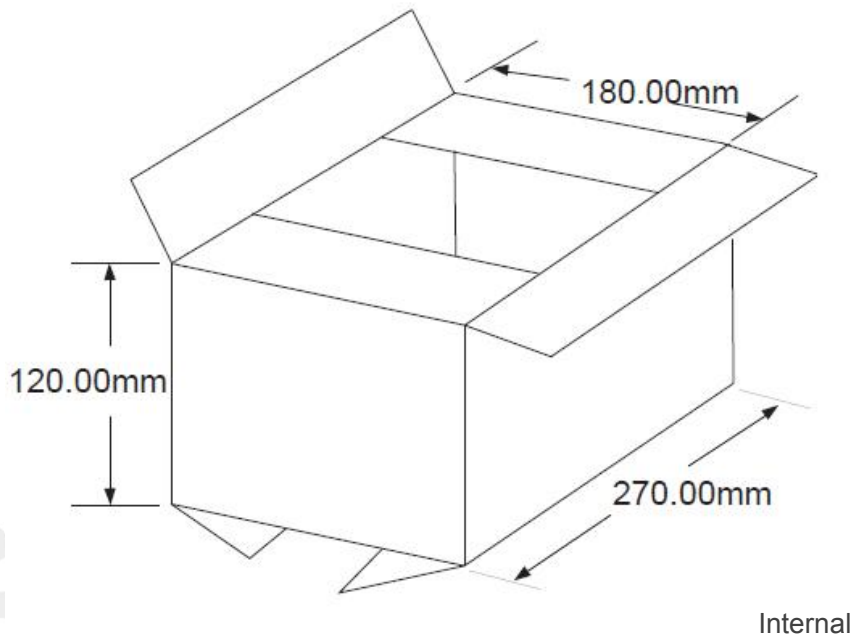

Figure 54: Small carton drawing

Table 68: Small carton size

Length ($\pm 10\text{mm}$)	Width ($\pm 10\text{mm}$)	Height ($\pm 10\text{mm}$)	Number
270	180	120	$8 \times 19 - 2 = 150$

Big carton drawing:

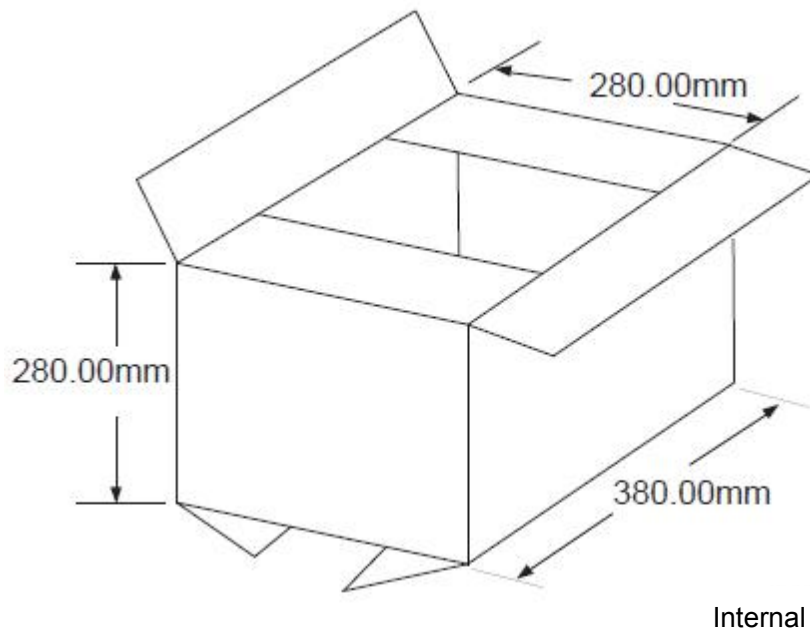

Figure 55: Big carton drawing

Table 69: Big carton size

Length ($\pm 10\text{mm}$)	Width ($\pm 10\text{mm}$)	Height ($\pm 10\text{mm}$)	Number
380	280	280	150*4=600

8 Appendix

8.1 Coding Schemes and Maximum Net Data Rates over Air Interface

Table 70: Coding schemes and maximum net data rates over air interface

HSDPA device category	Max data rate (peak)	Modulation type
Category 1	1.2Mbps	16QAM,QPSK
Category 2	1.2Mbps	16QAM,QPSK
Category 3	1.8Mbps	16QAM,QPSK
Category 4	1.8Mbps	16QAM,QPSK
Category 5	3.6Mbps	16QAM,QPSK
Category 6	3.6Mbps	16QAM,QPSK
Category 7	7.2Mbps	16QAM,QPSK
Category 8	7.2Mbps	16QAM,QPSK
Category 9	10.2Mbps	16QAM,QPSK
Category 10	14.4Mbps	16QAM,QPSK
Category 11	0.9Mbps	QPSK
Category 12	1.8Mbps	QPSK
Category 13	17.6Mbps	64QAM
Category 14	21.1Mbps	64QAM
Category 15	23.4Mbps	16QAM
Category 16	28Mbps	16QAM
Category 17	23.4Mbps	64QAM
Category 18	28Mbps	64QAM
Category 19	35.5Mbps	64QAM
Category 20	42Mbps	64QAM
Category 21	23.4Mbps	16QAM
Category 22	28Mbps	16QAM
Category 23	35.5Mbps	64QAM
Category 24	42.2Mbps	64QAM
HSPA device category	Max data rate (peak)	Modulation type
Category 1	0.96Mbps	QPSK
Category 2	1.92Mbps	QPSK
Category 3	1.92Mbps	QPSK
Category 4	3.84Mbps	QPSK

Category 5	3.84Mbps	QPSK
Category 6	5.76Mbps	QPSK
LTE-FDD device category (Downlink)		
LTE-FDD device category (Downlink)	Max data rate (peak)	Modulation type
Category 1	10Mbps	QPSK/16QAM/64QAM
Category 2	50Mbps	QPSK/16QAM/64QAM
Category 3	100Mbps	QPSK/16QAM/64QAM
Category 4	150Mbps	QPSK/16QAM/64QAM
Category 5	300Mbps	QPSK/16QAM/64QAM
Category 6	300Mbps	QPSK/16QAM/64QAM
LTE-FDD device category (Uplink)		
LTE-FDD device category (Uplink)	Max data rate (peak)	Modulation type
Category 1	5Mbps	QPSK/16QAM
Category 2	25Mbps	QPSK/16QAM
Category 3	50Mbps	QPSK/16QAM
Category 4	50Mbps	QPSK/16QAM
Category 5	75Mbps	QPSK/16QAM/64QAM
Category 6	50Mbps	QPSK/16QAM

SIMCom
Confidential

8.2 Related Documents

Table 71: Related documents

NO.	Title	Description
[1]	SIM8200 Series_AT Command Manual	AT Command Manual
[2]	ITU-T Draft new recommendation.25ter	Serial asynchronous automatic dialing and control
[3]	3GPP TS 51.010-1	Digital cellular telecommunications system (Release 5); Mobile Station (MS) conformance specification
[4]	3GPP TS 34.124	Electromagnetic Compatibility (EMC) for mobile terminals and ancillary equipment.
[5]	3GPP TS 34.121	Electromagnetic Compatibility (EMC) for mobile terminals and ancillary equipment.
[6]	3GPP TS 34.123-1	Technical Specification Group Radio Access Network; Terminal conformance specification; Radio transmission and reception (FDD)
[7]	3GPP TS 34.123-3	User Equipment (UE) conformance specification; Part 3: Abstract Test Suites.
[8]	EN 301 908-02 V2.2.1	Electromagnetic compatibility and Radio spectrum Ma (ERM); Base Stations (BS) and User Equipment (UE) IMT-2000. Third Generation cellular networks; Part 2 Harmonized EN for IMT-2000, CDMA Direct Spread (UTRA FDD) (UE) covering essential requirements of 3.2 of the R&TTE Directive
[9]	EN 301 489-24 V1.2.1	Electromagnetic compatibility and Radio Spectrum Ma (ERM); Electromagnetic Compatibility (EMC) standard radio equipment and services; Part 24: Specific condit for IMT-2000 CDMA Direct Spread (UTRA) for Mobile portable (UE) radio and ancillary equipment
[10]	IEC/EN60950-1(2001)	Safety of information technology equipment (2000)
[11]	3GPP TS 51.010-1	Digital cellular telecommunications system (Release 5 Mobile Station (MS) conformance specification
[12]	GCF-CC V3.23.1	Global Certification Forum – Certification Criteria
[13]	2002/95/EC	Directive of the European Parliament and of the Coun 27 January 2003 on the restriction of the use of certain hazardous substances in electrical and electronic equ (RoHS)
[14]	SIM8200G_LGA Antenna Port Mapping and Deign Guide	Antenna design guidelines for diversity receiver system
[15]	NSA_ENDC_For_8200G	ENDC list for SIM8200G
[16]	SIM8200EA&SIM8200G_CA COMBO list	CA list for SIM8200G
[17]	Antenna Tuner reference design	Antenna tuning method and antenna tuning reference example
[18]	SIM8200 Series Ethernet RT8125_HDK	About PCIe to Ethernet interface documents

8.3 Terms and Abbreviations

Table 72: Terms and abbreviations







Abbreviation	Description
ADC	Analog-to-Digital Converter
CS	Coding Scheme
CTS	Clear to Send
DRX	Discontinuous Reception
DTR	Data Terminal Ready
DTX	Discontinuous Transmission
EFR	Enhanced Full Rate
EMC	Electromagnetic Compatibility
ESD	Electrostatic Discharge
FDD	Frequency Division Dual
FR	Full Rate
GNSS	Global Navigation Satellite System
GPS	Global Positioning System
HR	Half Rate
I2C	Inter-Integrated Circuit
I2S	Inter-IC Sound
IMEI	International Mobile Equipment Identity
LTE	Long Term Evolution
MDIO	Management Data Input/Output
MMD	MDIO manageable device
MO	Mobile Originated
MSB	Most Significant Bit
PCB	Printed Circuit Board
PCIe	Peripheral Component Interface Express
RF	Radio Frequency
RGMII	Reduced Gigabit Media Independent Interface
SDIO	Secure Digital Input and Output
SIM	Subscriber Identification Module
SMS	Short Message Service
SPI	serial peripheral interface
TDD	Time Division Dual
TX	Transmit Direction
UART	Universal Asynchronous Receiver & Transmitter
VSWR	Voltage Standing Wave Ratio
SM	SIM phonebook

HSDPA	High Speed Downlink Packet Access
HSUPA	High Speed Uplink Packet Access
WCDMA	Wideband Code Division Multiple Access
(U)SIM	Universal subscriber identity module
UMTS	Universal mobile telecommunications system
UART	Universal asynchronous receiver transmitter
LB	Low Frequency Band
MHB	Middle and High Frequency Band
UHB	Ultra High Frequency Band
LAA	Limited Access Authorization
TRX	Transmit and Receive signal
UL-MIMO	Uplink- Multiple Input Multiple Output
DL-MIMO	Downlink- Multiple Input Multiple Output

SIMCom
Confidential

8.4 Safety Caution

Table 73: Safety caution

Marks	Requirements
	<p>When in a hospital or other health care facility, observe the restrictions about the use of mobiles. Switch the cellular terminal or mobile off, medical equipment may be sensitive and not operate normally due to RF energy interference.</p>
	<p>Switch off the cellular terminal or mobile before boarding an aircraft. Make sure it is switched off. The operation of wireless appliances in an aircraft is forbidden to prevent interference with communication systems. Forgetting to think much of these instructions may impact the flight safety, or offend local legal action, or both.</p>
	<p>Do not operate the cellular terminal or mobile in the presence of flammable gases or fumes. Switch off the cellular terminal when you are near petrol stations, fuel depots, chemical plants or where blasting operations are in progress. Operation of any electrical equipment in potentially explosive atmospheres can constitute a safety hazard.</p>
	<p>Your cellular terminal or mobile receives and transmits radio frequency energy while switched on. RF interference can occur if it is used close to TV sets, radios, computers or other electric equipment.</p>
	<p>Road safety comes first! Do not use a hand-held cellular terminal or mobile when driving a vehicle, unless it is securely mounted in a holder for hands free operation. Before making a call with a hand-held terminal or mobile, park the vehicle.</p>
	<p>Mobiles operate over radio frequency signals and cellular networks and cannot be guaranteed to connect in all conditions, especially with a mobile fee or an invalid (U)SIM card. While you are in this condition and need emergent help, please remember to use emergency calls. In order to make or receive calls, the cellular terminal or mobile must be switched on and in a service area with adequate cellular signal strength.</p> <p>Some networks do not allow for emergency call if certain network services or phone features are in use (e.g. lock functions, fixed dialing etc.). You may have to deactivate those features before you can make an emergency call.</p> <p>Also, some networks require that a valid (U)SIM card be properly inserted in the cellular terminal or mobile.</p>