

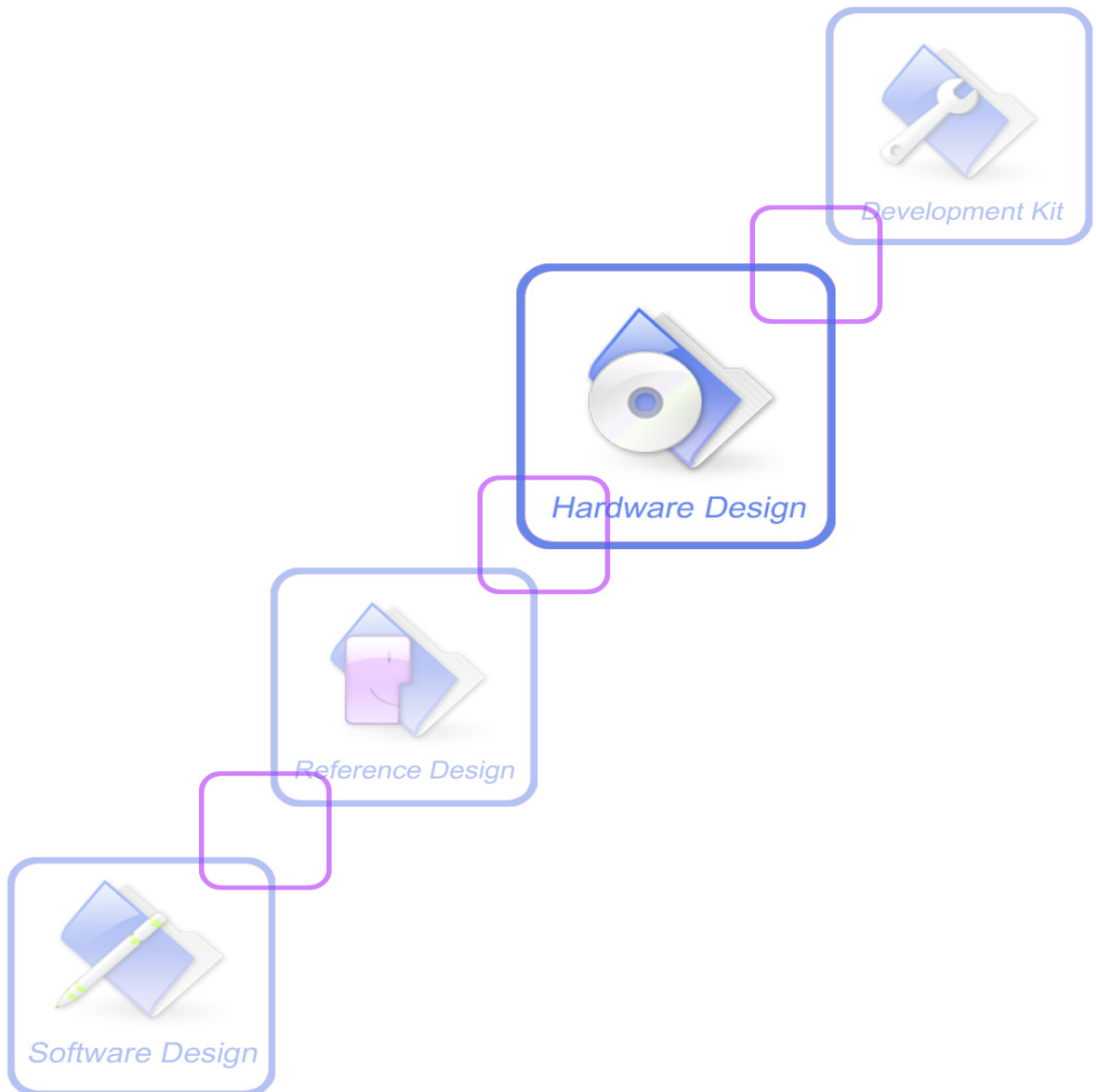

SIM800_Hardware Design_V1.10



Document Title	SIM800 Hardware Design
Version	1.10
Date	2019-08-13
Status	Release
Document Control ID	SIM800_Hardware Design_V1.10

General Notes

SIMCom offers this information as a service to its customers, to support application and engineering efforts that use the products designed by SIMCom. The information provided is based upon requirements specifically provided to SIMCom by the customers. SIMCom has not undertaken any independent search for additional relevant information, including any information that may be in the customer's possession. Furthermore, system validation of this product designed by SIMCom within a larger electronic system remains the responsibility of the customer or the customer's system integrator. All specifications supplied herein are subject to change.

Copyright

This document contains proprietary technical information which is the property of SIMCom Limited, copying of this document and giving it to others and the using or communication of the contents thereof, are forbidden without express authority. Offenders are liable to the payment of damages. All rights reserved in the event of grant of a patent or the registration of a utility model or design. All specification supplied herein are subject to change without notice at any time.

Copyright © Shanghai SIMCom Wireless Solutions Ltd. 2019

Contents

1. Introduction	10
2. SIM800 Overview	10
2.1. SIM800 Key Features	10
2.2. Operating Modes	12
2.3. SIM800 Functional Diagram	13
3. Package Information	14
3.1. Pin Out Diagram	14
3.2. Pin Description	15
3.3. Package Dimensions	18
4. Application Interface	20
4.1. Power Supply	20
4.1.1. Power Supply Pin	22
4.1.2. Monitoring Power Supply	22
4.2. Power on/off SIM800	22
4.2.1. Power on SIM800	22
4.2.2. Power off SIM800	24
4.2.3. Reset Function	25
4.3. Power Saving Mode	26
4.3.1. Function Mode	26
4.3.2. Sleep Mode (AT+CSCLK=1)	27
4.3.3. Wake Up SIM800 from Sleep Mode (AT+CSCLK=1)	27
4.4. RTC Backup	27
4.5. Serial Port and USB Interface	28
4.5.1. Function of Serial Port	29
4.5.2. Serial Port	29
4.5.3. USB Interface	31
4.5.4. Software Upgrade and Debug	32
4.6. RI Behaviors	33
4.7. Audio Interfaces	34
4.7.1. Speaker Interfaces Configuration	35
4.7.2. Microphone Interfaces Configuration	35
4.7.3. Audio Electronic Characteristic	36
4.7.4. TDD	36
4.8. Bluetooth	36
4.9. SIM Card Interface	37
4.9.1. SIM Card Application	37
4.9.2. SIM Card Design Consideration	38
4.9.3. Design Considerations for SIM Card Holder	38
4.10. PCM Interface	40
4.10.1. PCM Interface	41
4.11. Keypad Interface	41
4.12. I2C BUS	44
4.13. General Purpose Input/Output (GPIO)	44
4.14. ADC	45

4.15.	PWM.....	45
4.16.	Network Status Indication	46
4.17.	Operating Status Indication	47
4.18.	KPLED	47
4.19.	RF Synchronization Signal	48
4.20.	Antenna Interface	48
4.20.1.	GSM Antenna Interface	49
4.20.2.	Bluetooth Antenna Interface	50
5.	PCB Layout.....	51
5.1	PIN Assignment.....	51
5.2	Principle of PCB Layout.....	51
5.2.1	Antenna	51
5.2.2.	Power Supply	51
5.2.3	SIM Card Interface.....	51
5.2.4	Audio Interface.....	52
5.2.5	Others	52
5.3	Recommended PCB Layout	52
6.	Electrical, Reliability and Radio Characteristics	53
6.1	Absolute Maximum Ratings	53
6.2	Recommended Operating Conditions.....	53
6.3	Digital Interface Characteristics	53
6.4	SIM Card Interface Characteristics	54
6.5	SIM_VDD Characteristics.....	54
6.6	VDD_EXT Characteristics	54
6.7	VRTC Characteristics.....	54
6.8	Current Consumption (VBAT=4V).....	55
6.9	Electro-Static Discharge	56
6.10	Radio Characteristics	56
6.11	Module RF Receive Sensitivity	57
6.12	Module Operating Frequencies.....	57
7.	Manufacturing.....	59
7.1.	Top and Bottom View of SIM800	59
7.2.	Typical Solder Reflow Profile	59
7.3.	The Moisture Sensitivity Level	60
7.4.	Baking Requirements	60
8.	Packaging	61
9.	Appendix	63
I.	Related Documents.....	63
II.	Terms and Abbreviations	64
III.	Safety Caution	66

Table Index

TABLE 1: SIM800 KEY FEATURES.....	10
TABLE 2: CODING SCHEMES AND MAXIMUM NET DATA RATES OVER AIR INTERFACE	12
TABLE 3: OVERVIEW OF OPERATING MODES.....	12
TABLE 4: PIN DESCRIPTION	15
TABLE 5: RECOMMENDED ZENER DIODE	20
TABLE 6: ELECTRONIC CHARACTERISTIC OF THE RESET PIN.....	26
TABLE 7: THE CURRENT CONSUMPTION OF FUNCTION MODES (BS-PA-MFRMS=5).....	26
TABLE 8: SERIAL PORT AND USB PIN DEFINITION	28
TABLE 9: SERIAL PORT CHARACTERISTICS.....	29
TABLE 10: USB_VBUS OPERATION VOLTAGE	32
TABLE 11: RI BEHAVIORS.....	33
TABLE 12: AUDIO INTERFACE DEFINITION.....	34
TABLE 13: MICROPHONE INPUT CHARACTERISTICS.....	36
TABLE 14: AUDIO OUTPUT CHARACTERISTICS	36
TABLE 15: SIM PIN DEFINITION.....	37
TABLE 16: PIN DESCRIPTION (MOLEX SIM CARD HOLDER)	39
TABLE 17: PIN DESCRIPTION (AMPHENOL SIM CARD HOLDER).....	40
TABLE 18: PCM PIN DEFINITION	40
TABLE 19: PCM SPECIFICATION	41
TABLE 20: PIN DEFINITION OF THE KEYPAD INTERFACE.....	43
TABLE 21: PIN DEFINITION OF THE I2C.....	44
TABLE 22: PIN DEFINITION OF THE GPIO.....	44
TABLE 23: PIN DEFINITION OF THE ADC.....	45
TABLE 24: ADC SPECIFICATION	45
TABLE 25: PIN DEFINITION OF THE PWM	45
TABLE 26: PWM OUTPUT CHARACTERISTICS	46
TABLE 27: PWM MULTIPLEX FUNCTION.....	46
TABLE 28: PIN DEFINITION OF THE NETLIGHT	46
TABLE 29: STATUS OF THE NETLIGHT PIN.....	46
TABLE 30: PIN DEFINITION OF THE STATUS.....	47
TABLE 31: PIN DEFINITION OF THE KPLED	47
TABLE 32: KPLED SPECIFICATION.....	48
TABLE 33: DEFINITION OF THE RF_SYNC PIN.....	48
TABLE 34: RECOMMENDATION OF ESD COMPONENT.....	50
TABLE 35: ABSOLUTE MAXIMUM RATINGS.....	53
TABLE 36: RECOMMENDED OPERATING CONDITIONS	53
TABLE 37: DIGITAL INTERFACE CHARACTERISTICS	53
TABLE 38: SIM CARD INTERFACE CHARACTERISTIC.....	54
TABLE 39: SIM_VDD CHARACTERISTICS.....	54
TABLE 40: VDD_EXT CHARACTERISTICS	54
TABLE 41: VRTC CHARACTERISTICS	54
TABLE 42: CURRENT CONSUMPTION	55
TABLE 43: THE ESD CHARACTERISTICS (TEMPERATURE: 25°C, HUMIDITY: 45 %).....	56
TABLE 44: GSM 900 AND GSM 850 CONDUCTED RF OUTPUT POWER	56

TABLE 45: DCS 1800 AND PCS 1900 CONDUCTED RF OUTPUT POWER.....	57
TABLE 46: CONDUCTED RF RECEIVE SENSITIVITY	57
TABLE 47: OPERATING FREQUENCIES.....	58
TABLE 48: MOISTURE CLASSIFICATION LEVEL AND FLOOR LIFE	60
TABLE 49: BAKING REQUIREMENTS	60
TABLE 50: TRAY SIZE	61
TABLE 51: SMALL CARTON SIZE.....	62
TABLE 52: BIG CARTON SIZE	62
TABLE 53: RELATED DOCUMENTS	63
TABLE 54: TERMS AND ABBREVIATIONS.....	64
TABLE 55: SAFETY CAUTION.....	66

Figure Index

FIGURE 1: SIM800 FUNCTIONAL DIAGRAM.....	13
FIGURE 2: SIM800 PIN OUT DIAGRAM (TOP VIEW).....	14
FIGURE 3: DIMENSIONS OF SIM800 (UNIT: MM).....	18
FIGURE 4: RECOMMENDED PCB FOOTPRINT OUTLINE (UNIT: MM).....	19
FIGURE 5: REFERENCE CIRCUIT OF THE VBAT INPUT.....	20
FIGURE 6: REFERENCE CIRCUIT OF THE POWER SUPPLY.....	21
FIGURE 7: REFERENCE CIRCUIT OF THE DC-DC POWER SUPPLY.....	21
FIGURE 8: VBAT VOLTAGE DROP DURING TRANSMIT BURST.....	22
FIGURE 9: THE MINIMAL VBAT VOLTAGE REQUIREMENT AT VBAT DROP.....	22
FIGURE 10: POWER ON/OFF MODULE USING TRANSISTOR.....	23
FIGURE 11: POWER ON/OFF MODULE USING BUTTON.....	23
FIGURE 12: TIMING OF POWER ON MODULE.....	23
FIGURE 13: TIMING OF POWER OFF SIM800 BY PWRKEY.....	24
FIGURE 14: RESET CIRCUIT.....	25
FIGURE 15: RESET TIMING SEQUENCE.....	26
FIGURE 16: RTC SUPPLY FROM CAPACITOR.....	27
FIGURE 17: RTC SUPPLY FROM NON-CHARGEABLE BATTERY.....	28
FIGURE 18: RTC SUPPLY FROM RECHARGEABLE BATTERY.....	28
FIGURE 19: CONNECTION OF THE SERIAL PORT.....	30
FIGURE 20: LEVEL CONVERTING BY RESISTOR.....	30
FIGURE 21: ISOLATION CIRCUIT BY DIODES.....	30
FIGURE 22: TX LEVEL CONVERTING BY TRANSISTOR.....	31
FIGURE 23: RX LEVEL CONVERTING BY TRANSISTOR.....	31
FIGURE 24: USB REFERENCE CIRCUIT.....	32
FIGURE 25: CONNECTION FOR SOFTWARE UPGRADING.....	33
FIGURE 26: RI BEHAVIOUR OF VOICE CALLING AS A RECEIVER.....	33
FIGURE 27: RI BEHAVIOUR OF DATA CALLING AS A RECEIVER.....	34
FIGURE 28: RI BEHAVIOUR OF URC OR RECEIVE SMS.....	34
FIGURE 29: RI BEHAVIOUR AS A CALLER.....	34
FIGURE 30: SPEAKER REFERENCE CIRCUIT.....	35
FIGURE 31: MICROPHONE REFERENCE CIRCUIT.....	35
FIGURE 32: REFERENCE CIRCUIT OF THE 8-PIN SIM CARD HOLDER.....	37
FIGURE 33: REFERENCE CIRCUIT OF THE 6-PIN SIM CARD HOLDER.....	38
FIGURE 34: MOLEX 91228 SIM CARD HOLDER.....	39
FIGURE 35: AMPHENOL C707 10M006 512 SIM CARD HOLDER.....	40
FIGURE 36: PCM REFERENCE CIRCUIT.....	41
FIGURE 37: TRADITIONAL KEYPAD REFERENCE CIRCUIT.....	42
FIGURE 38: EXTENDED KEYPAD REFERENCE CIRCUIT.....	42
FIGURE 39: ENHANCE THE ESD PERFORMANCE OF KEYPAD CIRCUIT.....	43
FIGURE 40: KEYPAD DETECTED.....	43
FIGURE 41: GPIO TIMING SEQUENCES.....	45
FIGURE 42: REFERENCE CIRCUIT OF PWM DRIVE BUZZER.....	46
FIGURE 43: REFERENCE CIRCUIT OF NETLIGHT.....	47
FIGURE 44: KPLED DRIVER REFERENCE CIRCUIT.....	48
FIGURE 45: RF_SYNC SIGNAL DURING TRANSMIT BURST.....	48
FIGURE 46: GSM ANTENNA MATCHING CIRCUIT.....	49

FIGURE 47: GSM SIMPLE ANTENNA MATCHING CIRCUIT	49
FIGURE 48: BLUETOOTH ANTENNA MATCHING CIRCUIT	50
FIGURE 49: RECOMMENDED PCB LAYOUT	52
FIGURE 50: TOP AND BOTTOM VIEW OF SIM800	59
FIGURE 51: TYPICAL SOLDER REFLOW PROFILE	59
FIGURE 52: PACKAGING DIAGRAM.....	61
FIGURE 53: TRAY DRAWING.....	61
FIGURE 54: SMALL CARTON DRAWING.....	62
FIGURE 55: BIG CARTON DRAWING	62

Version History

Date	Version	Description of change	Author
2013-07-29	1.00	Origin	Ma Honggang Teng Lili
2013-08-05	1.01	Update RESET pin parameter; Update figure 12, 13, 15.	Ma Honggang
2013-08-21	1.02	Update figure 3 and figure 23; Update chapter 7.3;	Ma Honggang
2014-01-17	1.03	Update table32, correct NETLIGHT to PIN 52;	Ma Honggang
2014-03-11	1.04	Update table 11	Ma Honggang
2014-03-25	1.05	Update figure 32 and figure 33, The 100nF capacitor changed;	Ma Honggang
2014-07-18	1.06	Update figure 12 and 13, timing of VDD_EXT changed; Update the baudrate that SIM800 supports; Rename some pin name to follow the SIMCom naming rules; Uptade table 6, table9; Add GPIO timing sequences of figure 43; Update figure 51;	Ma Honggang
2014-12-01	1.07	Update table 45	WuChengbing
2015-03-05	1.08	Update table 5,10and 12; Update figure 51; Update the chapter power supply; Update the chapter bluetooth; Update the frequency of PWM that SIM800 supports;	WuChengbing
2016-06-21	1.09	Update figure 48 and 49,add a TVS; Update Table 38, add recommendation ESD component Delete the automatic power off function related to temperature	LiuQiang Zhang xiuyu
2019-08-13	1.10	Update figure 3 Add chapter 8	Zhou Jing

1. Introduction

This document describes SIM800 hardware interface in great detail.

This document can help user to quickly understand SIM800 interface specifications, electrical and mechanical details. With the help of this document and other SIM800 application notes, user guide, users can use SIM800 to design various applications quickly.

2. SIM800 Overview

Designed for global market, SIM800 is a quad-band GSM/GPRS module that works on frequencies GSM 850MHz, EGSM 900MHz, DCS 1800MHz and PCS 1900MHz. SIM800 features GPRS multi-slot class 12/ class 10 (optional) and supports the GPRS coding schemes CS-1, CS-2, CS-3 and CS-4.

With a tiny configuration of 24*24*3mm, SIM800 can meet almost all the space requirements in users' applications, such as M2M, smart phone, PDA and other mobile devices.

SIM800 has 68 SMT pads, and provides all hardware interfaces between the module and customers' boards.

- Support up to 5*5*2 Keypads.
- One full function UART port, and can be configured to two independent serial ports.
- One USB port can be used as debugging and firmware upgrading.
- Audio channels which include a microphone input and a receiver output.
- Programmable general purpose input and output.
- One SIM card interface.
- Support Bluetooth function.
- Support one PWM.
- PCM

SIM800 is designed with power saving technique so that the current consumption is as low as 1.2mA in sleep mode.

SIM800 integrates TCP/IP protocol and extended TCP/IP AT commands which are very useful for data transfer applications. For details about TCP/IP applications, please refer to *document [11]*.

2.1. SIM800 Key Features

Table 1: SIM800 key features

Feature	Implementation
Power supply	3.4V ~4.4V
Power saving	Typical power consumption in sleep mode is 1.2mA (BS-PA-MFRMS=9)
Frequency bands	<ul style="list-style-type: none"> ● SIM800 Quad-band: GSM 850, EGSM 900, DCS 1800, PCS 1900. SIM800 can search the 4 frequency bands automatically. The frequency bands also can be set by AT command "AT+CBAND". For details, please refer to <i>document [1]</i>. ● Compliant to GSM Phase 2/2+
Transmitting power	<ul style="list-style-type: none"> ● Class 4 (2W):GSM850,EGSM900 ● Class 1 (1W):DCS1800,PCS1900
GPRS connectivity	<ul style="list-style-type: none"> ● GPRS multi-slot class 12 (default)

	<ul style="list-style-type: none"> ● GPRS multi-slot class 1~12 (option)
Temperature range	<ul style="list-style-type: none"> ● Normal operation:-40°C ~ +85°C ● Storage temperature -45°C ~ +90°C
GPRS	<ul style="list-style-type: none"> ● GPRS data downlink transfer: max. 85.6 kbps ● GPRS data uplink transfer: max. 85.6 kbps ● Coding scheme: CS-1, CS-2, CS-3 and CS-4 ● PAP protocol for PPP connect ● Integrate the TCP/IP protocol. ● Support Packet Broadcast Control Channel (PBCCH)
CSD	<ul style="list-style-type: none"> ● Support CSD transmission ● CSD transmission rates:2.4,4.8,9.6,14.4 kbps
USSD	<ul style="list-style-type: none"> ● Unstructured Supplementary Services Data (USSD) support
SMS	<ul style="list-style-type: none"> ● MT, MO, CB, Text and PDU mode ● SMS storage: SIM card
SIM interface	Support SIM card: 1.8V, 3V
Antenna Interface	Antenna pad
Audio features	Speech codec modes: <ul style="list-style-type: none"> ● Half Rate (ETS 06.20) ● Full Rate (ETS 06.10) ● Enhanced Full Rate (ETS 06.50 / 06.60 / 06.80) ● Adaptive multi rate (AMR) ● Echo Cancellation ● Noise Suppression
Serial port and USB interface	<p>Serial port:</p> <ul style="list-style-type: none"> ● Full modem interface with status and control lines, unbalanced, asynchronous. ● 1200bps to 460800bps ● Can be used for AT commands for data stream ● Support RTS/CTS hardware handshake and software ON/OFF flow control ● Multiplex ability according to GSM 07.10 Multiplexer Protocol ● Autobauding supports baud rate from 1200 bps to 115200bps <p>USB interface:</p> <ul style="list-style-type: none"> ● Can be used as debugging and firmware upgrading
Phonebook management	Support phonebook types: SM, FD, LD, RC, ON, MC
SIM application toolkit	GSM 11.14 Release 99
Real time clock	Support RTC
Alarm function	Can be set by AT command
Physical characteristics	Size:24*24*3mm Weight:3.2g
Firmware upgrade	Firmware upgrading by serial port or USB interface(recommend to use USB port)

Table 2: Coding schemes and maximum net data rates over air interface

Coding scheme	1 timeslot	2 timeslot	4 timeslot
CS-1	9.05kbps	18.1kbps	36.2kbps
CS-2	13.4kbps	26.8kbps	53.6kbps
CS-3	15.6kbps	31.2kbps	62.4kbps
CS-4	21.4kbps	42.8kbps	85.6kbps

2.2. Operating Modes

The table below summarizes the various operating modes of SIM800.

Table 3: Overview of operating modes

Mode	Function
Normal operation	GSM/GPRS SLEEP Module will automatically go into sleep mode if the conditions of sleep mode are enabling and there is no on air or hardware interrupt (such as GPIO interrupt or data on serial port). In this case, the current consumption of module will reduce to the minimal level. In sleep mode, the module can still receive paging message and SMS.
	GSM IDLE Software is active. Module registered to the GSM network, and the module is ready to communicate.
	GSM TALK Connection between two subscribers is in progress. In this case, the power consumption depends on network settings such as DTX off/on, FR/EFR/HR, hopping sequences, antenna.
	GPRS STANDBY Module is ready for GPRS data transfer, but no data is currently sent or received. In this case, power consumption depends on network settings and GPRS configuration.
	GPRS DATA There is GPRS data transfer (PPP or TCP or UDP) in progress. In this case, power consumption is related with network settings (e.g. power control level); uplink/downlink data rates and GPRS configuration (e.g. used multi-slot settings).
Power off	Normal Power off by sending the AT command “AT+CPOWD=1” or using the PWRKEY. The power management unit shuts down the power supply for the baseband part of the module, and only the power supply for the RTC is remained. Software is not active. The serial port is not accessible. Power supply (connected to VBAT) remains applied.
Minimum functionality mode	AT command “AT+CFUN” can be used to set the module to a minimum functionality mode without removing the power supply. In this mode, the RF part of the module will not work or the SIM card will not be accessible, or both RF part and SIM card will be closed, and the serial port is still accessible. The power consumption in this mode is lower than normal mode.

2.3. SIM800 Functional Diagram

The following figure shows a functional diagram of SIM800:

- GSM baseband engine
- PMU
- RF part
- Antenna interfaces
- Other interfaces

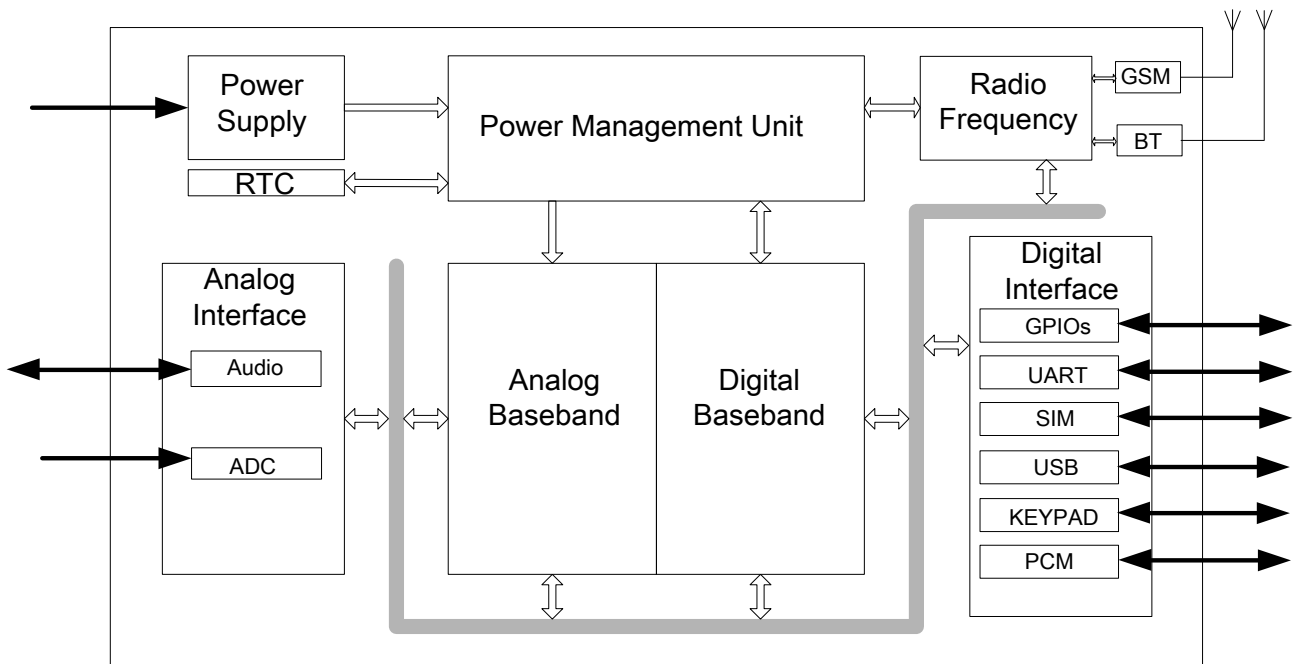

Figure 1: SIM800 functional diagram

3. Package Information

3.1. Pin Out Diagram

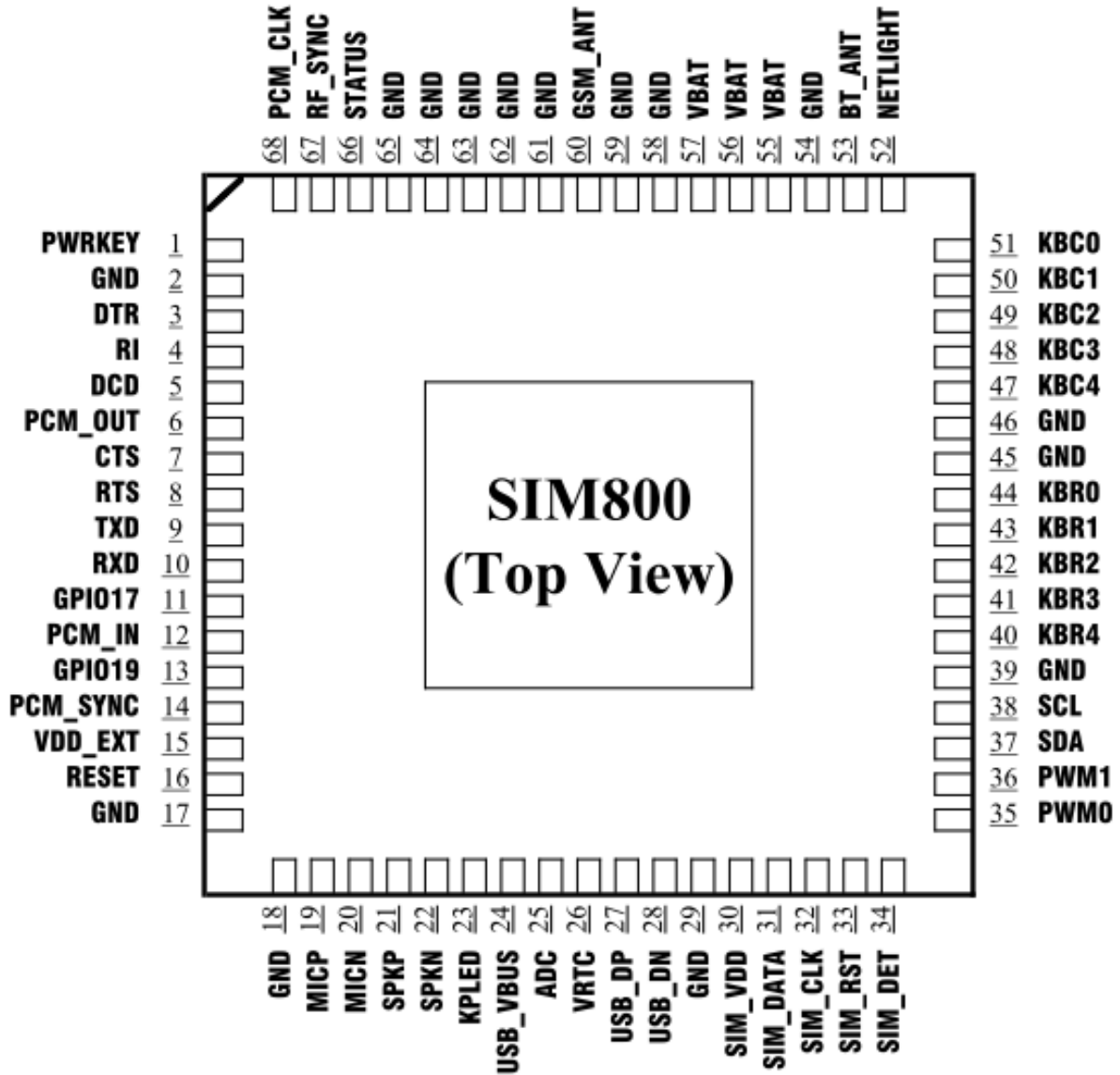

Figure 2: SIM800 pin out diagram (Top view)

3.2. Pin Description

Table 4: Pin description

Pin name	Pin number	I/O	Description	Comment
Power supply				
VBAT	55,56,57	I	SIM800 supplies 3 VBAT pins, and the power range is from 3.4V to 4.4V. Power supply should provide sufficient current so that the module can work normally; the peak current is nearly 2A.	Zener diode is Strongly recommended to anti surge on VBAT.
VRTC	26	I/O	Power supply for RTC	It is recommended to connect VRTC to a battery or a capacitor (e.g. 4.7uF).
VDD_EXT	15	O	2.8V power output	Keep floating if unused.
GND	2,17,18,29,3 9,45,46,54,5 8,59,61,62,6 3,64,65		Ground	GND for VBAT recommend to use 62, 63, 64, 65 pin
Power on/off				
PWRKEY	1	I	PWRKEY should be pulled low at least 1.2 second and then released to power on/down the module.	Internally pulled up to VBAT.
Audio interface				
MICP	19	I	Differential audio input	Keep floating if unused.
MICN	20			
SPKP	21	O	Differential audio output	
SPKN	22			
PCM interface				
PCM_OUT	6	O	PCM interface for audio	Keep floating if unused.
PCM_IN	12	I		
PCM_SYNC	14	O		
PCM_CLK	68	I		
Keypad interface				
KBC4	47	I	Support up to 50 buttons (5*5*2)	Keep floating if unused. (KBC0 can not be pulled down).
KBC3	48	I		
KBC2	49	I		
KBC1	50	I		
KBC0	51	I		
KBR4	40	O		

KBR3	41	O		
KBR2	42	O		
KBR1	43	O		
KBR0	44	O		
GPIO				
GPIO17	11	I/O	Programmable general purpose input and output.	
GPIO19	13	I/O		
NETLIGHT	52	O	Network status	Can not multiplex with GPIO function.
STATUS	66	O	Power on status	
Serial port				
DTR	3	I	Data terminal ready	Keep floating if unused.
RI	4	O	Ring indicator	
DCD	5	O	Data carrier detect	
CTS	7	O	Clear to send	
RTS	8	I	Request to send	
TXD	9	O	Transmit data	
RXD	10	I	Receive data	
USB interface				
USB_VBUS	24	I	Debug and firmware upgrading	Keep floating if unused.
USB_DP	27	I/O		
USB_DN	28	I/O		
ADC				
ADC	25	I	10 bit general analog to digital converter	Keep floating if unused.
PWM				
PWM0	35	O	Pulse-width modulation, multiplex with GPIO.	Keep floating if unused.
PWM1	36	O	Pulse-width modulation, multiplex with GPIO.	
I2C				
SDA	37	I/O	I2C serial bus data	Internal pulled up to 2.8V via 4.7K Ω
SCL	38	O	I2C serial bus clock	
SIM interface				
SIM_VDD	30	O	Voltage supply for SIM card. Support 1.8V or 3V for SIM card	All signals of SIM interface should be protected against ESD with a TVS diode array.
SIM_DATA	31	I/O	SIM data input/output	
SIM_CLK	32	O	SIM clock	
SIM_RST	33	O	SIM reset	
SIM_DET	34	I	SIM card detection	
Antenna				
GSM_ANT	60	I/O	GSM antenna port	Impedence must be controlled to 50 Ω .

BT_ANT	53	I/O	Bluetooth antenna port	Impedance must be controlled to 50Ω.
RF synchronization				
RF_SYNC	67	O	RF burst synchronous signal	Do not pull up
Other signal				
RESET	16	I	Reset input(Active low)	
KPLED	23	I	Drive keypad backlight	

3.3. Package Dimensions

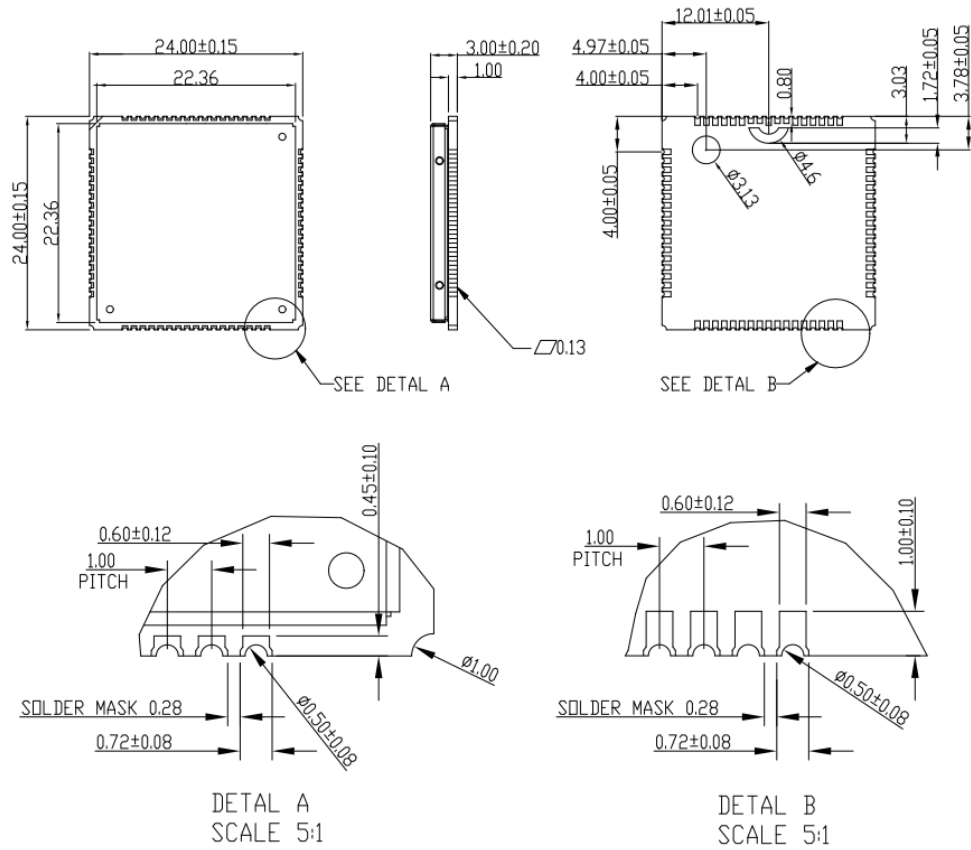

Figure 3: Dimensions of SIM800 (Unit: mm)

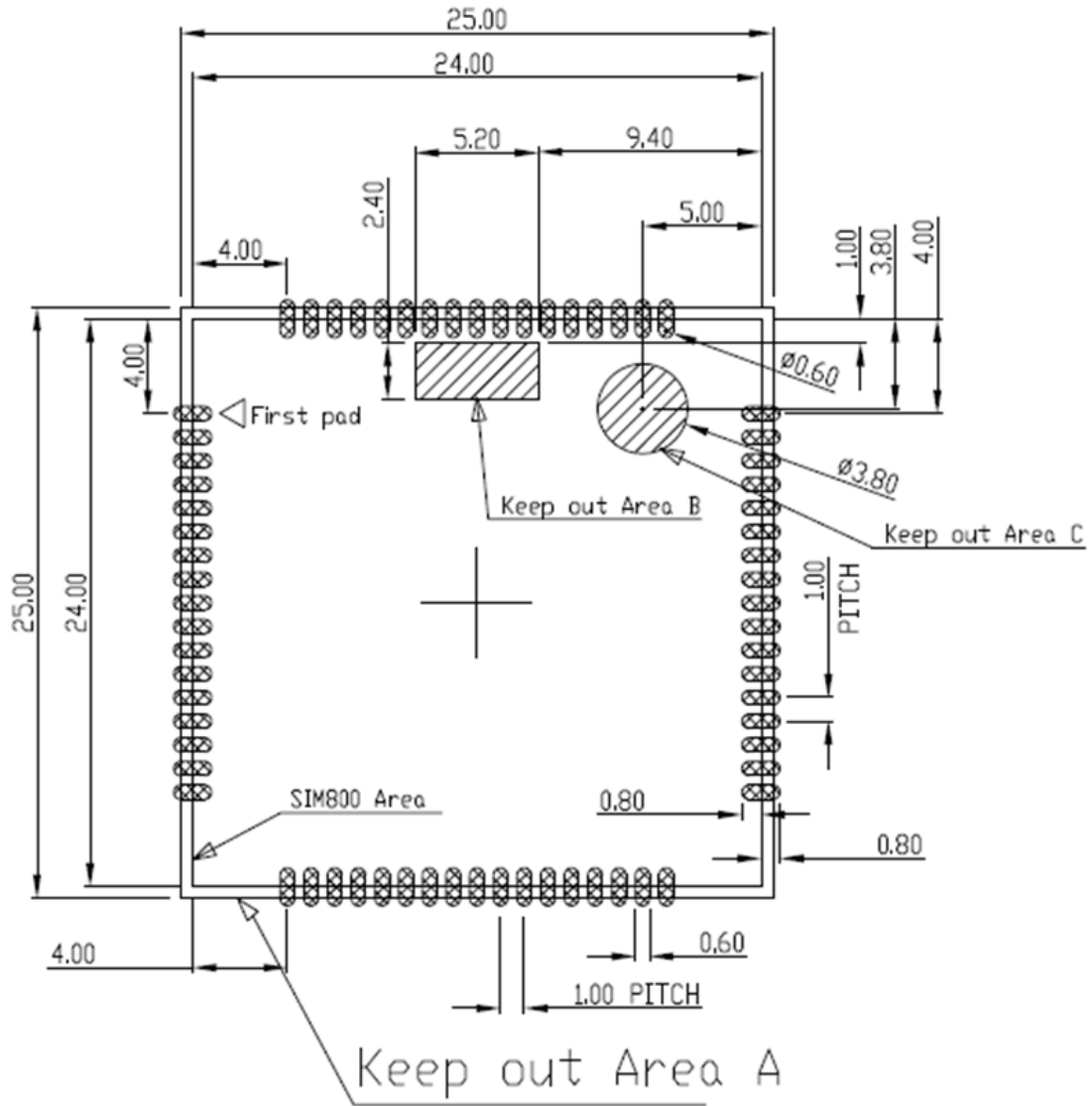

Figure 4: Recommended PCB footprint outline (Unit: mm)

Note: Keep copper out of area B and C.

4. Application Interface

4.1. Power Supply

The power supply range of SIM800 is from 3.4V to 4.4V. Recommended voltage is 4.0V. The transmitting burst will cause voltage drop and the power supply must be able to provide sufficient current up to 2A. For the VBAT input, a bypass capacitor (low ESR) such as a 100 μ F is strongly recommended.

For the VBAT input, a 100 μ F Tantalum capacitor (C_A low ESR) and a 1 μ F~10 μ F Ceramics capacitor C_B are strongly recommended. The 33pF and 10pF capacitors can effectively eliminate the high frequency interference. A 5.1V/500mW Zener diode is strongly recommended, the diode can prevent chip from damaging by the voltage surge. These capacitors and Zener diode should be placed as close to SIM800 VBAT pins as possible.

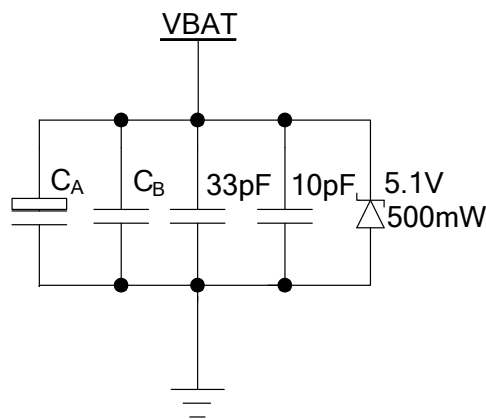

Figure 5: Reference circuit of the VBAT input

Table 5: Recommended Zener diode

	Vendor	Part number	Power(watts)	Packages
1	On semi	MMSZ5231BT1G	500mW	SOD123
2	Prisemi	PZ3D4V2H	500mW	SOD323
3	Vishay	MMSZ4689-V	500mW	SOD123
4	Crownpo	CDZ55C5V1SM	500mW	0805

The following figure is the reference design of +5V input power supply. The designed output for the power supply is 4.1V, thus a linear regulator can be used.

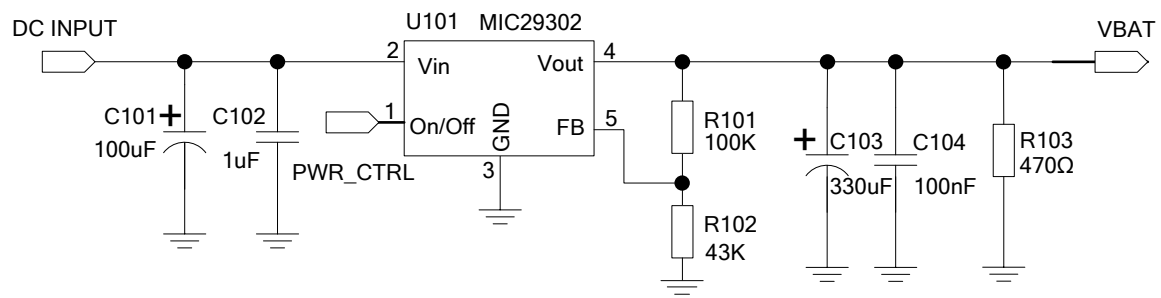
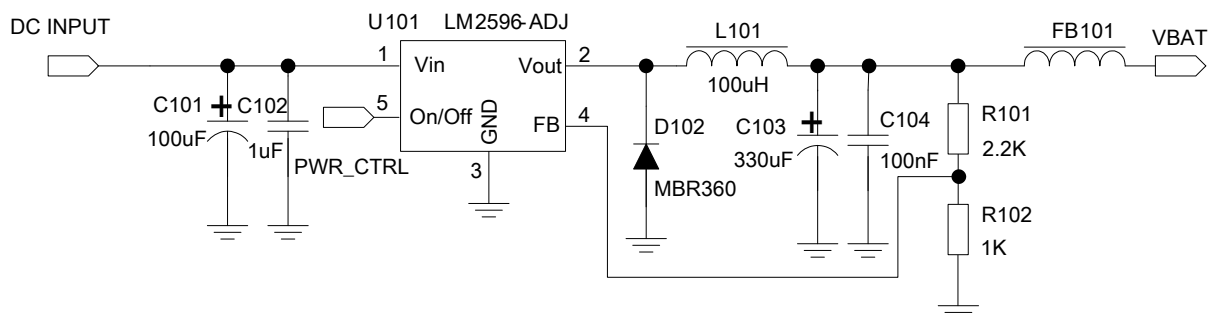

Figure 6: Reference circuit of the power supply

If there is a high drop-out between the input and the desired output (VBAT), a DC-DC power supply will be preferable because of its better efficiency. The following figure is the reference circuit. FB101 is very important, customer can get better EMI feature with appropriate filtering bead.



C

Figure 7: Reference circuit of the DC-DC power supply

The single 3.7V Li-ion cell battery can be connected to SIM800 VBAT pins directly. But the Ni-Cd or Ni-MH battery must be used carefully, since their maximum voltage can rise over the absolute maximum voltage of the module and damage it.

When battery is used, the total impedance between battery and VBAT pins should be less than 150mΩ.

The following figure shows the VBAT voltage drop at the maximum power transmit phase, and the test condition is as following:

VBAT=4.0V,

A VBAT bypass capacitor $C_A=100\mu\text{F}$ tantalum capacitor (ESR=0.7Ω),

Another VBAT bypass capacitor $C_B=1\mu\text{F}$. (See C_A and C_B in figure 5)

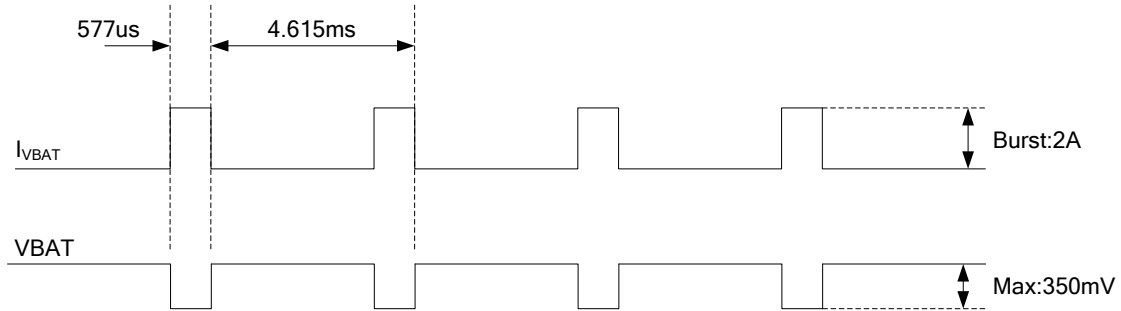

Figure 8: VBAT voltage drop during transmit burst

4.1.1. Power Supply Pin

The VBAT pins are used for power input, and pin 62,63,64,65 should be connected to the power GND. VRTC pin is power supply of the RTC circuit in the module. VDD_EXT will output 2.8V when module powered up.

When designing the power supply in user's application, pay special attention to power losses. Ensure that the input voltage never drop below 3.4V even when current consumption rises to 2A in the transmit burst. If the power voltage drops below 3.4V, the module may be shut down automatically. The PCB traces from the VBAT pins to the power supply must be wide enough (at least 80mil) to decrease voltage drops in the transmit burst. The power IC and the bypass capacitor should be placed to the module as close as possible.



Figure 9: The minimal VBAT voltage requirement at VBAT drop

Note: Hardware Power down voltage is 3.0V.

4.1.2. Monitoring Power Supply

The AT command "AT+CBC" can be used to monitor the VBAT voltage. For details please refer to *document [1]*.

4.2. Power on/off SIM800

4.2.1. Power on SIM800

User can power on SIM800 by pulling down the PWRKEY pin at least 1.2 second and then release. This pin is already pulled up to VBAT in the module internal, so external pull up is not necessary. Reference circuit is shown as below.

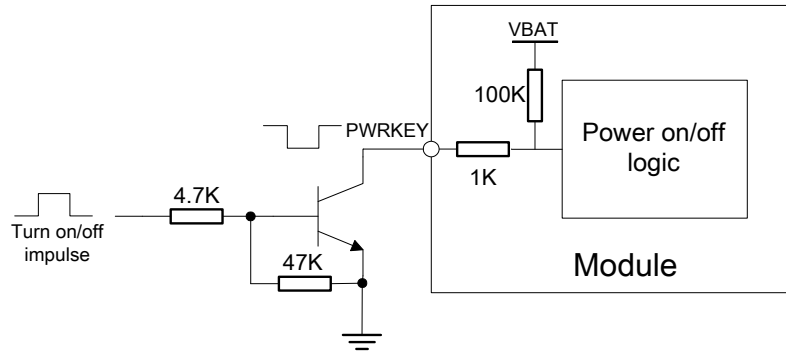

Figure 10: Power on/off module using transistor

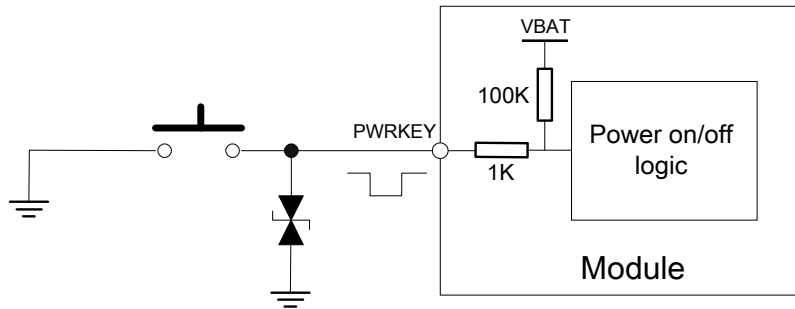

Figure 11: Power on/off module using button

The power on timing is illustrated as following figure.

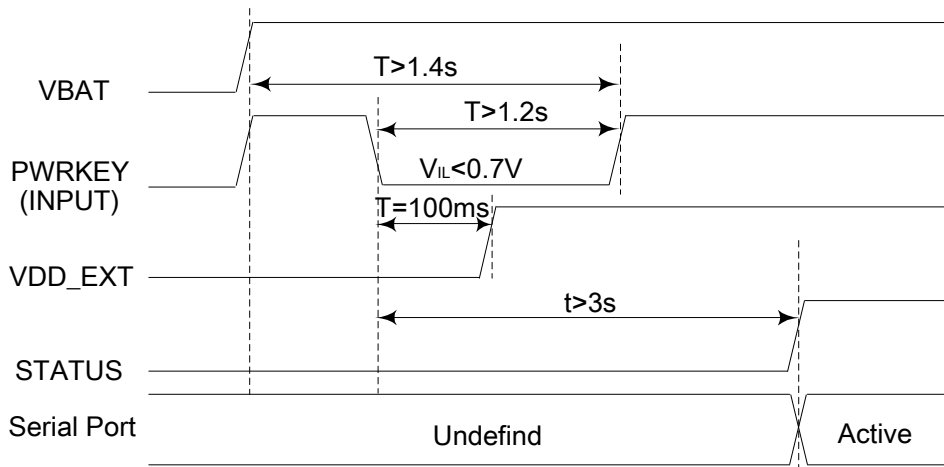

Figure 12: Timing of power on module

When power on procedure is completed, SIM800 will send following URC to indicate that the module is ready to operate at fixed baud rate.

RDY

This URC does not appear when autobauding function is active.

Note: User can use AT command “AT+IPR=x” to set a fixed baud rate and save the configuration to non-volatile flash memory. After the configuration is saved as fixed baud rate, the Code “RDY” should be received from the serial port every time when SIM800 is powered on. For details, please refer to the chapter “AT+IPR” in document [1].

4.2.2. Power off SIM800

SIM800 will be powered off in the following situations:

- Normal power off procedure: power off SIM800 by the PWRKEY pin.
- Normal power off procedure: power off SIM800 by AT command “AT+CPOWD=1”.
- Abnormal power off: over-voltage or under-voltage automatic power off.

4.2.2.1. Power off SIM800 by the PWRKEY Pin

User can power off SIM800 by pulling down the PWRKEY pin for at least 1.5 second and then release. Please refer to the power on circuit. The power off sequence is illustrated in following figure.

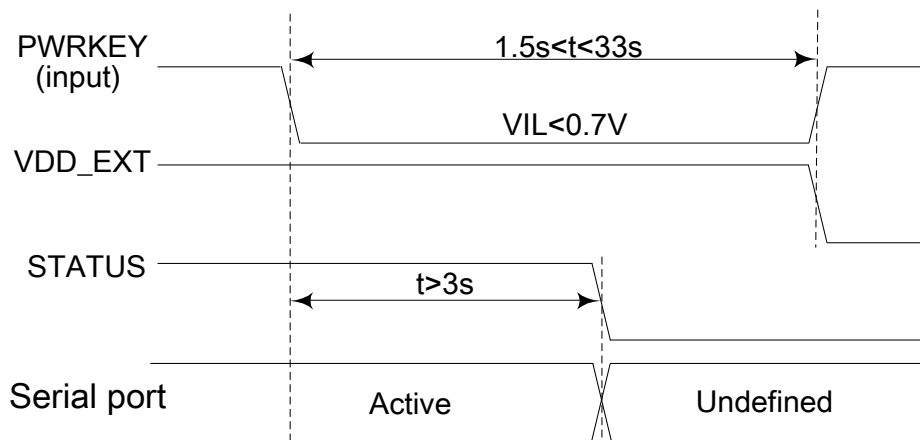

Figure 13: Timing of Power off SIM800 by PWRKEY

Note: When module is powered off by pulling down PWRKEY, the pull down time exceeds 33 seconds will course the module power up.

This procedure makes the module log off from the network and allows the software to enter into a secure state to save data before completely shut down.

Before the completion of the power off procedure, the module will send URC:

NORMAL POWER DOWN

At this moment, AT commands can not be executed any more, and only the RTC is still active. Power off mode can also be indicated by STATUS pin, which is low level at this time.

4.2.2.2. Power off SIM800 by AT Command

SIM800 can be powered down by AT command “AT+CPOWD=1”. This procedure makes the module log off from the network and allows the software to enter into a secure state to save data before completely shut down.

Before the completion of the power off procedure, the module will send URC:

NORMAL POWER DOWN

At this moment, AT commands can not be executed any more, and only the RTC is still active. Power off mode can also be indicated by STATUS pin, which is at low level at this time.

For details about the AT command “AT+CPOWD”, please refer to *document [1]*

4.2.2.3. Over-voltage or Under-voltage Power off

The module software monitors the VBAT voltage constantly.

If the voltage $\leq 3.49\text{V}$, the following URC will be reported:

UNDER-VOLTAGE WARNNING

If the voltage $\geq 4.3\text{V}$, the following URC will be reported:

OVER-VOLTAGE WARNNING

If the voltage $< 3.39\text{V}$, the following URC will be reported, and the module will be automatically powered off.

UNDER-VOLTAGE POWER DOWN

If the voltage $> 4.4\text{V}$, the following URC will be reported, and the module will be automatically powered off.

OVER-VOLTAGE POWER DOWN

At this moment, AT commands can not be executed any more, and only the RTC is still active. Power off mode can also be indicated by STATUS pin, which is low level at this time.

4.2.3. Reset Function

SIM800 also have a RESET pin used to reset the module. This function is used as an emergency reset only when AT command “AT+CPOWD=1” and the PWRKEY pin have no effect. User can pull the RESET pin to ground, and then the module will restart.

This pin is already isolated in the module, so the external isolation is not necessary. Following figure is internal circuit of the RESET pin.

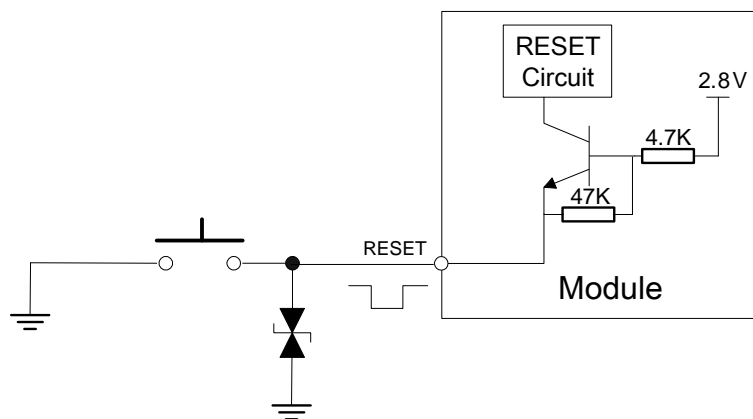

Figure 14: Reset circuit

The typical value of RESET pin high level is 2.8V, so for the 3V or 3.3V, customer could use MCU’s GPIO to driver this pin directly, resistor in serial the RESET signal could enhance the ESD performance but the value should not be higher than 100Ω , otherwise the level of RESET could be lower than threshold value; RESET hardware parameters can refer to the following table.

Table 6: Electronic characteristic of the RESET Pin

Pin name	Symbol	Min	Typ	Max	Unit
RESET	V_{IH}	2.7	-	-	V
	V_{IL}	-	-	0.6	V
	$T_{pull\ down}$	0.3	105	-	mS

The reset scenarios are illustrated in the following figures.

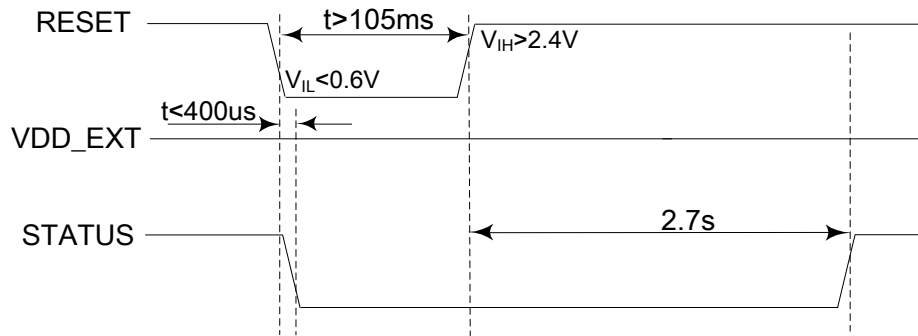
Figure 15: Reset timing sequence

4.3. Power Saving Mode

SIM800 has two power saving modes: Minimum function mode and sleep mode. The AT command “AT+CSCLK=1” can be used to set SIM800 into sleep mode. The AT command “AT+CFUN=<fun>” can be used to set SIM800 into minimum function. When SIM800 is in sleep mode and minimum function mode, the current of module is the lowest.

4.3.1. Function Mode

There are three function modes, which could be set by the AT command “AT+CFUN=<fun>”. The command provides the choice of the function levels <fun>=0, 1, 4.

- AT+CFUN=0: Minimum function.
- AT+CFUN=1: Full function (default).
- AT+CFUN=4: Flight mode (disable RF function).

Table 7: The current consumption of function modes (BS-PA-MFRMS=5)

<Fun>	Current consumption(mA) (CSCLK=1)
0	0.8
1	1.3
4	0.8

Minimum function mode minimizes the current consumption to the lowest level. If SIM800 is set to minimum functionality by “AT+CFUN=0”, the RF function and SIM card function will be disabled. In this case, the serial port is still accessible, but all AT commands correlative with RF function and SIM card function will not

be accessible.

For detailed information about the AT Command “AT+CFUN=<fun>”, please refer to *document [1]*.

4.3.2. Sleep Mode (AT+CSCLK=1)

User can control SIM800 module to enter or exit the sleep mode (AT+CSCLK=1) by DTR signal. When DTR is in high level and without interrupt (on air and hardware such as GPIO interrupt or data in serial port), SIM800 will enter sleep mode automatically. In this mode, SIM800 can still receive paging or SMS from network but the serial port is not accessible.

Note: *Autobauding is the default setting. Module can not enter sleep mode if the baud rate of MCU's serial port not synchronous with module after module power on.*

4.3.3. Wake Up SIM800 from Sleep Mode (AT+CSCLK=1)

When SIM800 is in sleep mode (AT+CSCLK=1), the following methods can wake up the module:

- Pull down DTR pin.
The serial port will be active after DTR pin is pulled to low level for about 50ms.
- Receive a voice or data call from network.
- Receive a SMS from network.
- Receive external interrupt

4.4. RTC Backup

VRTC is an input pin when the VBAT is not supplied by external power. When the VBAT power supply is in present and the backup battery is in low voltage state, VRTC can charge the backup battery. The RTC power supply of module can be provided by an external capacitor or a battery (non-chargeable or rechargeable) through the VRTC. The following figures show various reference circuits for RTC back up.

- **External capacitor backup**

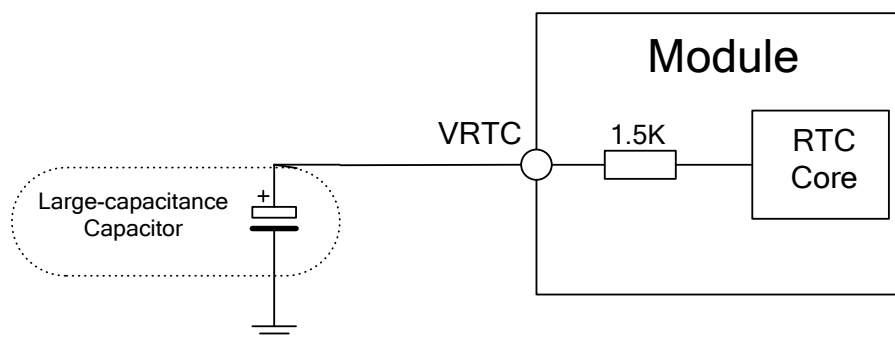

Figure 16: RTC supply from capacitor

- **Non-chargeable battery backup**

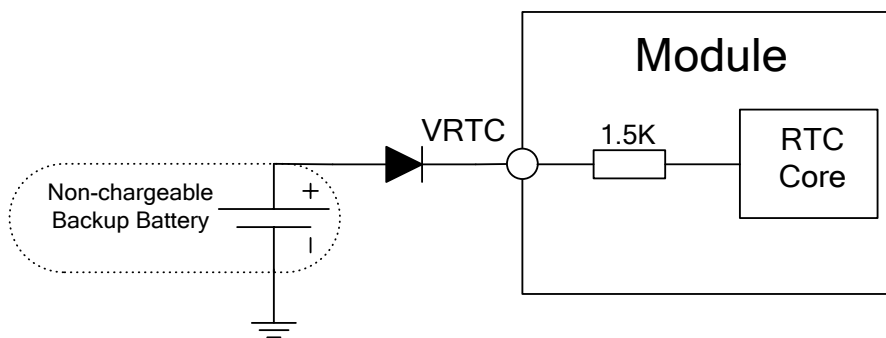

Figure 17: RTC supply from non-chargeable battery

- **Rechargeable battery backup**

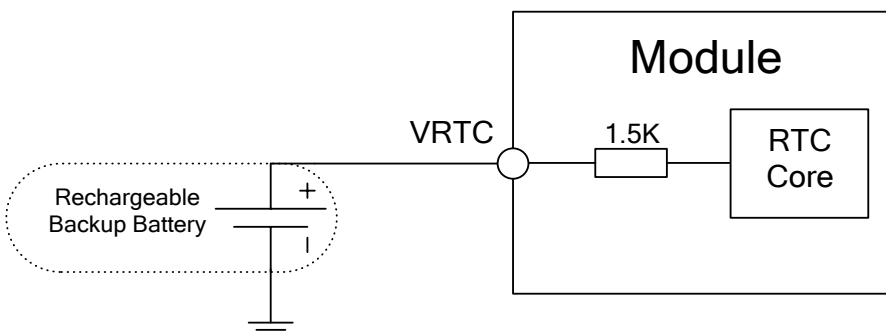

Figure 18: RTC supply from rechargeable battery

Note: RTC can not be directly connected to the VBAT, VRTC refer to table 44.

4.5. Serial Port and USB Interface

SIM800 provides one unbalanced asynchronous serial port. The module is designed as a DCE (Data Communication Equipment). The following figure shows the connection between module and client (DTE).

Table 8: Serial port and USB pin definition

	Name	Pin number	Function
Serial Port	DTR	3	Data terminal ready
	RI	4	Ring indicator
	DCD	5	Data carrier detect
	CTS	7	Clear to send
	RTS	8	Request to send
	TXD	9	Transmit data
	RXD	10	Receive data
USB Interface	USB_VBUS	24	USB power supply
	USB_DP	27	USB data line positive
	USB_DN	28	USB data line negative

Note: Hardware flow control is disabled by default. The AT command “AT+IFC=2,2” can enable hardware flow control. The AT command “AT+IFC=0,0” can disable hardware flow control. For more details, please refer to document [1].

Table 9: Serial port characteristics

Symbol	Min	Max	Unit
V _{IL}	-0.3	0.7	V
V _{IH}	2.1	3.0	V
V _{OL}	-	0.4	V
V _{OH}	2.4	-	V

4.5.1 Function of Serial Port

Serial port:

- Full modem device.
- Contains data lines TXD and RXD, hardware flow control lines RTS and CTS, status lines DTR, DCD and RI.
- Serial port can be used for CSD FAX, GPRS service and AT communication. It can also be used for multiplex function. For details about multiplex function, please refer to *table 11*.
- Serial port supports the following baud rates:
1200, 2400, 4800, 9600, 19200, 38400, 57600, 115200bps, 230400 and 460800bps;
- Autobauding only supports the following baud rates:
1200, 2400, 4800, 9600, 19200, 38400, 57600 and 115200bps
- The default setting is autobauding.

Autobauding allows SIM800 to automatically detect the baud rate of the host device. Pay more attention to the following requirements:

- **Synchronization between DTE and DCE:**
When DCE powers on with autobauding enabled, firstly, user must send character “A” or “a” to synchronize the baud rate. It is recommended to send “AT” until DTE receives the “OK” response, which means DTE and DCE are correctly synchronized. For more information please refer to the AT command “AT+IPR”.
- **Restrictions of autobauding operation:**
The DTE serial port must be set at 8 data bits, no parity and 1 stop bit.
The URC such as "RDY", "+CFUN: 1" and "+CPIN: READY" will not be reported.

Note: User can use AT command “AT+IPR=x” to set a fixed baud rate and the setting will be saved to non-volatile flash memory automatically. After the configuration is set as fixed baud rate, the URC such as "RDY", "+CFUN: 1" and "+CPIN: READY" will be reported when SIM800 is powered on.

4.5.2 Serial Port

The following figure shows the connection between module and client (DTE).

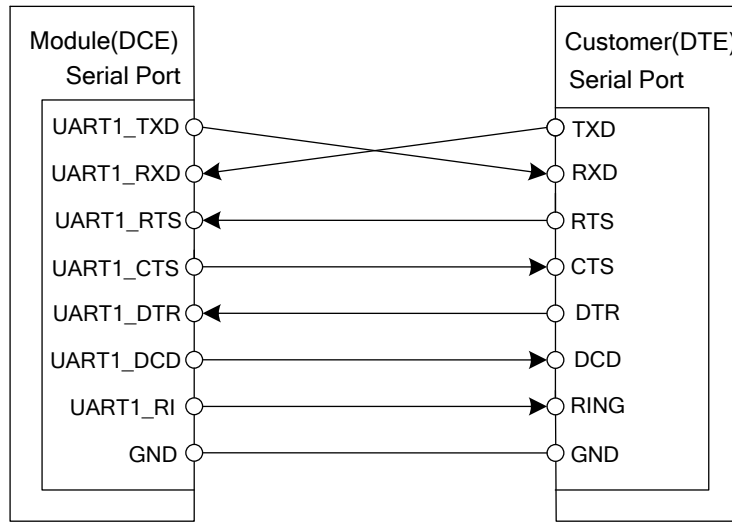

Figure 19: Connection of the serial port

If the voltage of UART is 3.3V, the following reference circuits are recommended. If the voltage is 3.0V, please change the resistors in the following figure from 5.6K to 14K.

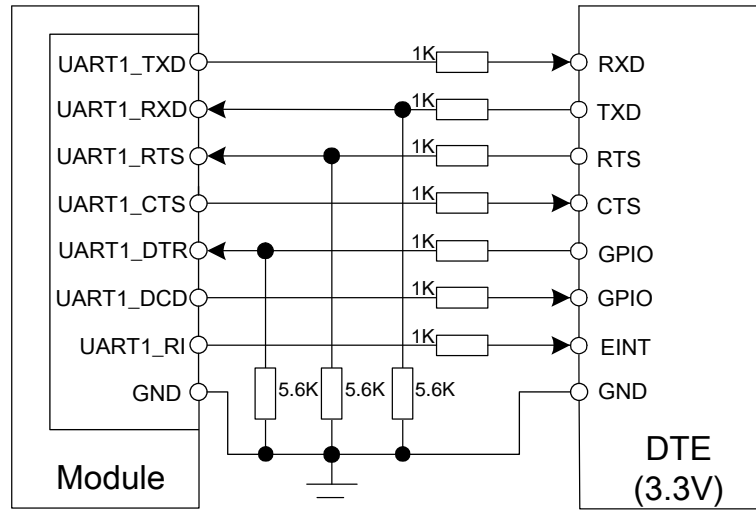

Figure 20: Level converting by resistor

If the voltage of UART is 3V or 3.3V, user also can use following reference circuits:

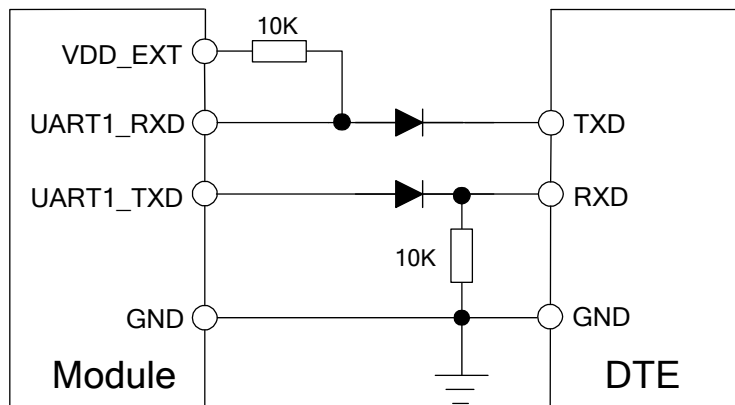

Figure 21: Isolation circuit by diodes

Note: when a diode used to isolate voltage cross, customer should notice that there's voltage drop on the diode. And the signal's voltage level should meet the customer's electrical character. The recommend diode is Schottky diode e.g. RB551V-30TE-17 and SDM20U40.

If the voltage of UART is 5V on customer side, customer can use the following reference circuits:

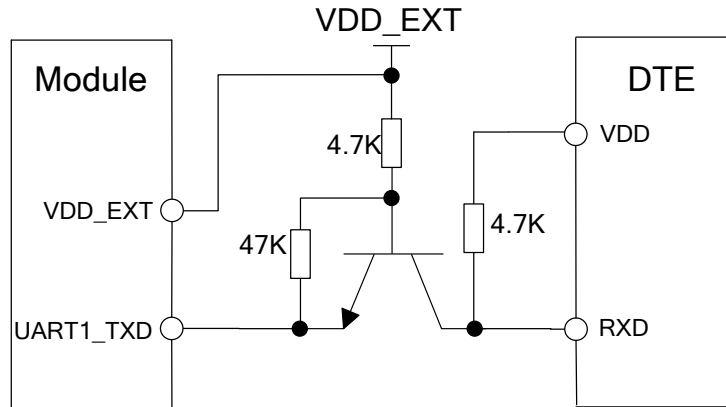

Figure 22: TX level converting by transistor

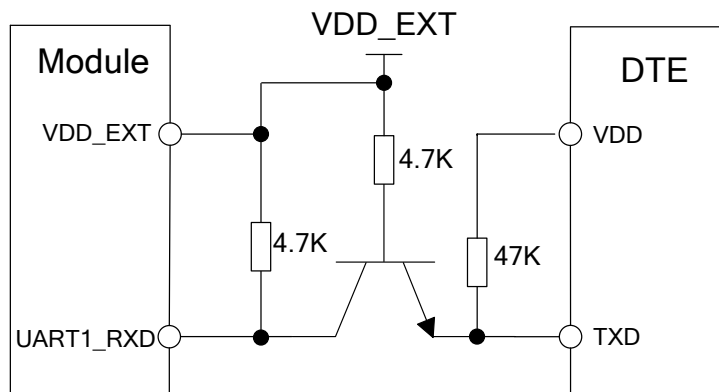

Figure 23: RX level converting by transistor

Note: The recommend Transistors' part numbers are 2SC4617TLR and PBHV8115Z.

4.5.3 USB Interface

USB interface supports software debug function. When power on the module, connect USB_VBUS, USB_DP, USB_DN and GND to PC, then install the driver successfully, a UART port could be recognized by the PC, customer could achieve the software Debug purpose with this UART port.

The following diagram is recommended:

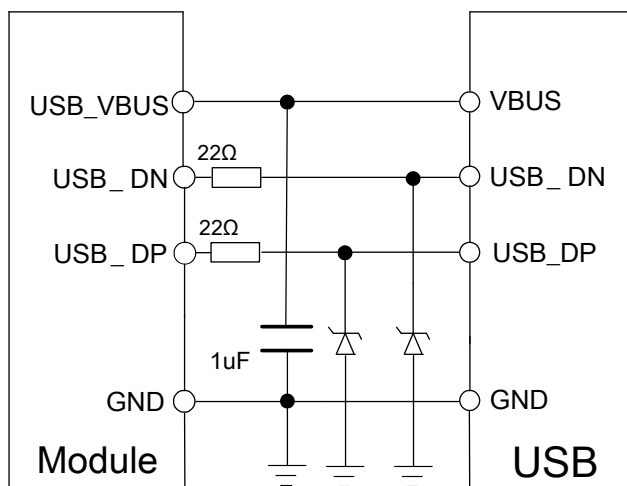

Figure 24: USB reference circuit

The maximum allowable cap load of TVS on USB data line should be less than 5pF (e.g. ESD9L5.0ST5G and ESD9M5.0ST5G). The USB_DP and USB_DN should be routed in differential traces.

Note: please reserve the USB interface or test point for debug.

Table 10: USB_VBUS operation voltage

Pin	Min	Typ	Max	Unit
USB_VBUS	4.3	5.0	7.0	V

Note: USB_VBUS is only used for USB inserting detection, can not be used as a power source.

4.5.4 Software Upgrade and Debug

USB and UART interfaces can be used for firmware upgrade.

If customer upgrading firmware via the USB port, SIM800 must be powered first, then connect USB_VBUS, USB_DP, USB_DN and GND to PC. There is no need to operate PWRKEY pin in the whole procedure, when SIM800 detects USB_VBUS and could communicate normally by USB_DP and USB_DN, module will enter USB download mode automatically.

Note: When only USB_DP and USB_DN connected, no USB_VBUS, customer need to pull down KBC0 before power on the module, then press the PWRKEY button, the module will enter download mode;

If customer upgrading firmware via the UART port, it is strongly recommended that reserve the TXD, RXD, GND and PWRKEY pins to IO connector for the upgrade, and PWRKEY pin should connect to GND while upgrading. Refer to the following figure for upgrading software.

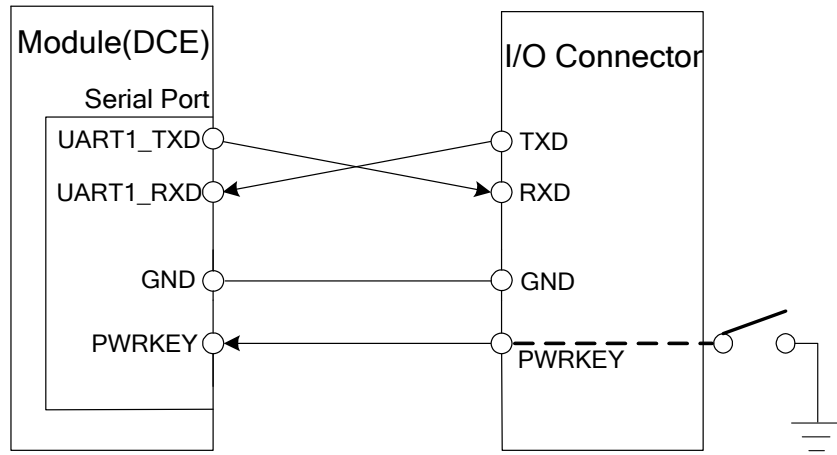

Figure 25: Connection for software upgrading

The serial port supports the CMOS level. If user connects the module to the computer, the level shifter should be added between the DCE and DTE.

4.6. RI Behaviors

Table 11: RI Behaviors

State	RI response
Standby	High
Voice call	The pin is changed to low. When any of the following events occur, the pin will be changed to high: (1)Establish the call (2)Hang up the call
Data call	The pin is changed to low. When any of the following events occur, the pin will be changed to high: (1)Establish the call (2)Hang up the call
SMS	The pin is changed to low, and kept low for 120ms when a SMS is received. Then it is changed to high.
URC	The pin is changed to low, and kept low for 120ms when some URCs are reported. Then it is changed to high. For more details, please refer to <i>document [10]</i> .

The behavior of the RI pin is shown in the following figure when the module is used as a receiver.

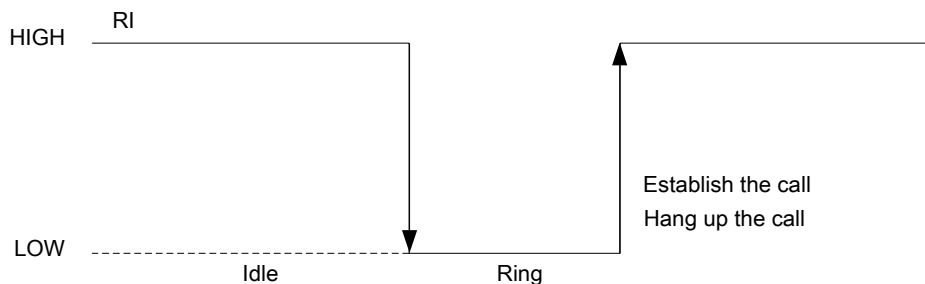

Figure 26: RI behaviour of voice calling as a receiver

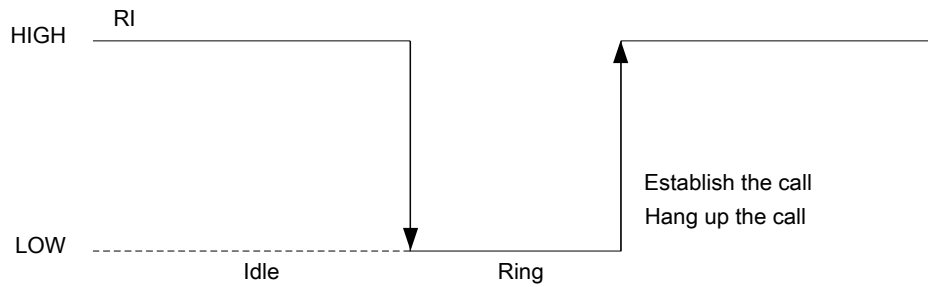

Figure 27: RI behaviour of data calling as a receiver

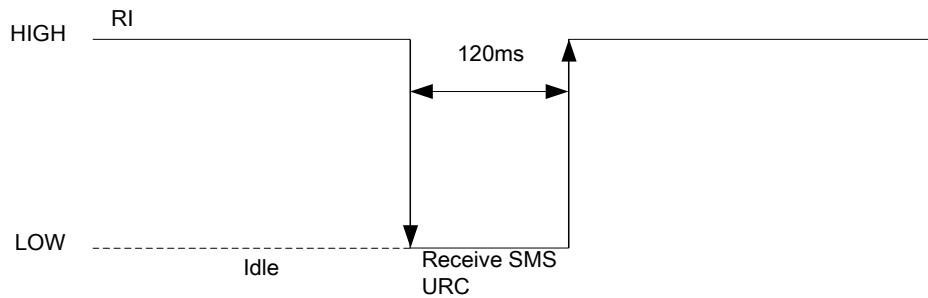

Figure 28: RI behaviour of URC or receive SMS

However, if the module is used as caller, the RI will remain high. Please refer to the following figure.

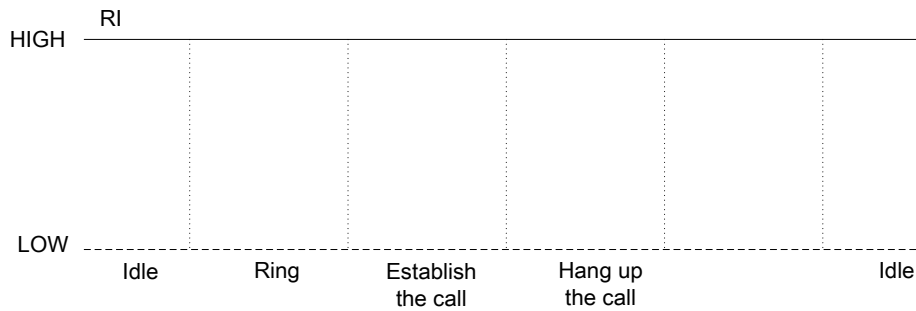

Figure 29: RI behaviour as a caller

4.7. Audio Interfaces

SIM800 provides one analog input, which could be used for electret microphone. The module also provides one analog output. The output can directly drive 32Ω receiver.

Table 12: Audio interface definition

	Pin name	Pin number	Function
Audio channel	MICP	19	Audio input positive
	MICN	20	Audio input negative
	SPKP	21	Audio output positive
	SPKN	22	Audio output negative

“AT+CMIC” is used to adjust the input gain level of microphone. “AT+SIDET” is used to set the side-tone level. In addition, “AT+CLVL” is used to adjust the output gain level. For more details, please refer to *document [1]*

In order to improve audio performance, the following reference circuits are recommended. The audio signals have to be layout according to differential signal layout rules as shown in following figures.

4.7.1. Speaker Interfaces Configuration

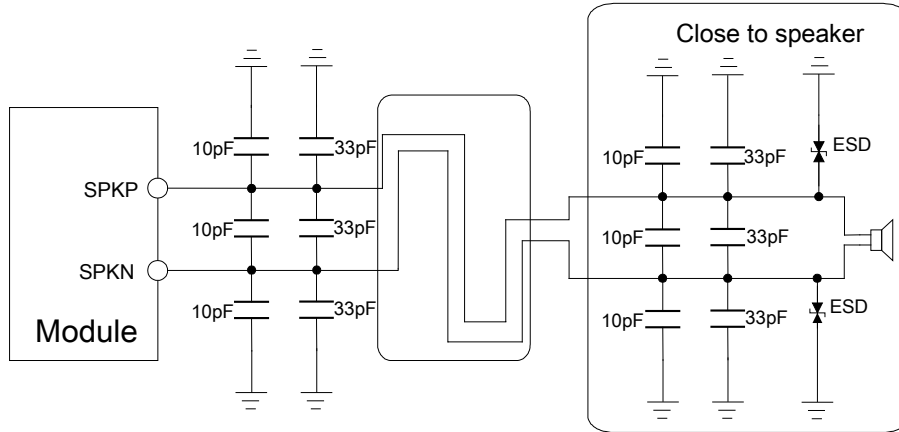

Figure 30: Speaker reference circuit

4.7.2. Microphone Interfaces Configuration

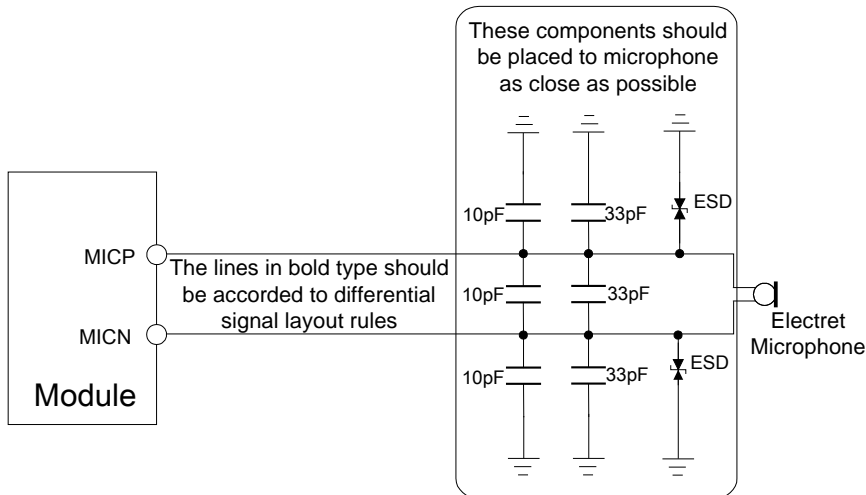

Figure 31: Microphone reference circuit

4.7.3. Audio Electronic Characteristic

Table 13: Microphone input characteristics

Parameter	Min	Typ	Max	Unit
Mic biasing voltage		1.9	2.2	V
Working Current			2	mA
Input impedance(differential)	13	20	27	K Ω
Idle channel noise			-67	dBm
SINAD	Input level:-40dBm0	29		dB
	Input level:0dBm0		69	dB

Table 14: Audio output characteristics

parameter	Conditions	Min	Typ	Max	Unit
Normal output	$R_L=32\ \Omega$ receiver	-	-	90	mW

4.7.4. TDD

GSM signal could interfere audio by coupling or conducting. Coupling noise could be filtered by adding 33 pF and 10pF capacitor over audio lines.33pF capacitor could eliminate noise from GSM900MHz, while 10pF capacitor could eliminate noise from DCS1800MHz frequency. Coupling noise has great relatives with PCB layout. Under some scenarios, TDD noise from GSM 900MHz frequency affects heavily, but some different story is from GSM1800MHz frequency, so customer should develop this filter solution according to field test result.

GSM antenna is the key coupling interfering source of TDD noise. Pay attention to the layout of audio lines which should be far away from RF cable & antenna and VBAT pin. The bypass capacitor for filtering should be placed near module and another group placed near to connector.

Conducting noise is mainly caused by the VBAT drop. If Audio PA was powered by VBAT directly, then there will be some cheep noise from SPK output easily. So, it's better to put big capacitor and ferrite bead near audio PA input.

TDD noise has something to do with GND signal surely. If GND signal issued not good, lots of high-frequency noise will interfere MIC and speaker over bypass capacitor. So, take care of GND well during PCB layout.

4.8. Bluetooth

SIM800 supports Bluetooth function, customer only needs to design the Bluetooth antenna, and then customer can operate Bluetooth conveniently by AT commands.

- Fully compliant with Bluetooth specification3.0
- Support operation with GPS and GSM/GPRS worldwide radio systems
- Fully integrated PA provides 10dbm output power
- Up to 4 simultaneous active ACL links

- Support sniff mode
- Supports PCM interface and built-in programmable transcoders for liner voice with transmission

4.9. SIM Card Interface

The SIM interface complies with the GSM Phase 1 specification and the new GSM Phase 2+ specification for FAST 64 kbps SIM card. Both 1.8V and 3.0V SIM card are supported. The SIM interface is powered from an internal regulator in the module.

4.9.1. SIM Card Application

Table 15: SIM pin definition

Name	Pin	function
SIM_VDD	30	Voltage supply for SIM card. Support 1.8V or 3V SIM card
SIM_DATA	31	SIM data input/output
SIM_CLK	32	SIM clock
SIM_RST	33	SIM reset
SIM_DET	34	SIM card detection

It is recommended to use an ESD protection component such as ON SEMI (www.onsemi.com) SMF12CT1G. The SIM peripheral circuit should be close to the SIM card socket. The reference circuit of the 8-pin SIM card holder is illustrated in the following figure.

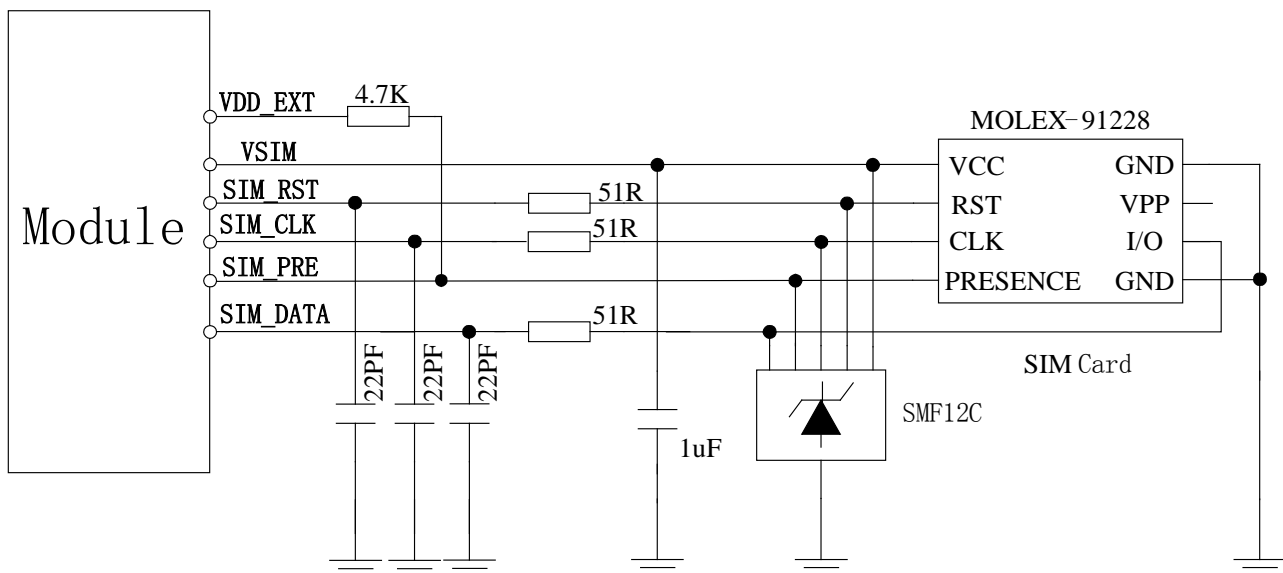

Figure 32: Reference circuit of the 8-pin SIM card holder

The SIM_DET pin is used for detection of the SIM card hot plug in. User can select the 8-pin SIM card holder to implement SIM card detection function. AT command “AT+CSDT” is used to enable or disable SIM card detection function. For details of this AT command, please refer to *document [1]*.

If the SIM card detection function is not used, user can keep the SIM_DET pin open. The reference circuit of

6-pin SIM card holder is illustrated in the following figure.

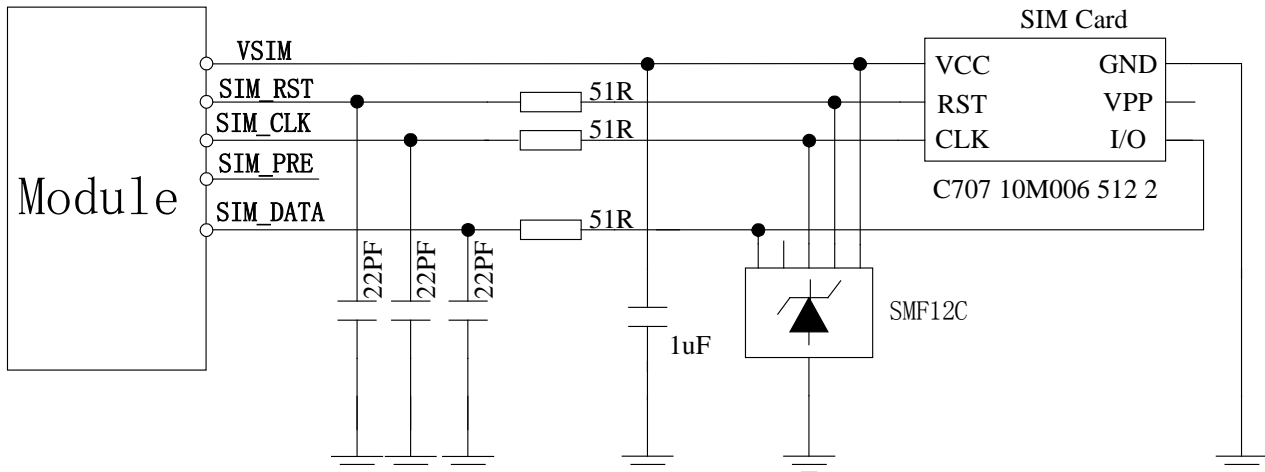

Figure 33: Reference circuit of the 6-pin SIM card holder

4.9.2. SIM Card Design Consideration

SIM card circuit is susceptible to interference, causing the SIM card failures or some other situations, so it is strongly recommended to follow these guidelines while designing:

- Make sure that SIM card holder should far away from GSM antenna while in PCB layout.
- SIM traces should keep away from RF lines, VBAT and high-speed signal lines.
- The traces should be as short as possible.
- Keep SIM holder's GND connect to main ground directly.
- Shielding the SIM card signal by ground well.
- Recommended to place a 1μF capacitor on SIM_VDD line and keep close to the holder.
- Add some TVS and the parasitic capacitance should not exceed 50pF, and 51Ω resistor in serials the SIM signal could enhance ESD protection.

4.9.3. Design Considerations for SIM Card Holder

For 8 pins SIM card holder, SIMCom recommends to use Molex 91228. User can visit <http://www.molex.com> for more information about the holder.

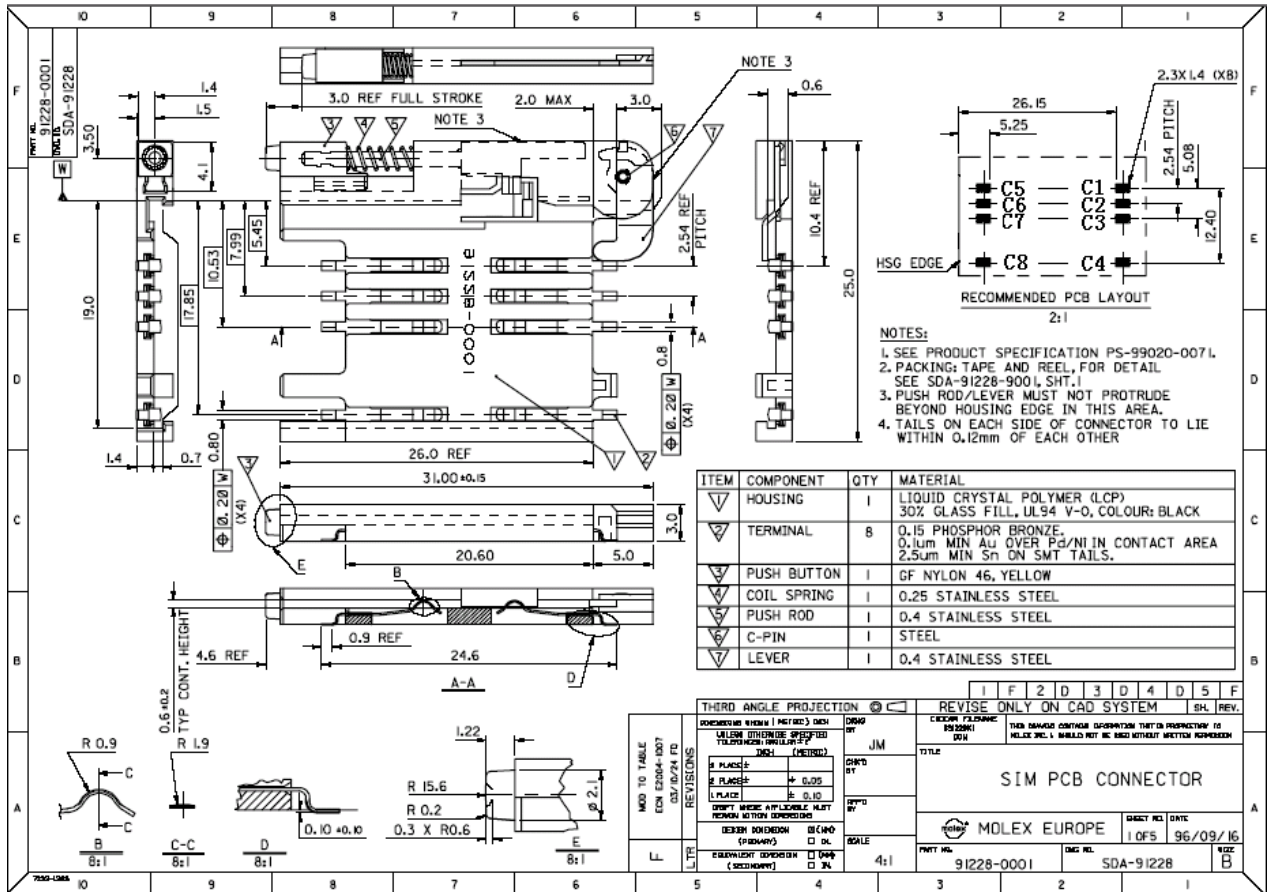

Figure 34: Molex 91228 SIM card holder

Table 16: Pin description (Molex SIM card holder)

Pin name	Signal	Description
C1	SIM_VDD	SIM card power supply
C2	SIM_RST	SIM card reset
C3	SIM_CLK	SIM card clock
C4	GND	Connect to GND
C5	GND	Connect to GND
C6	VPP	Not connect
C7	SIM_DATA	SIM card data I/O
C8	SIM_DET	Detect SIM card presence

For 6-pin SIM card holder, SIMCom recommends to use Amphenol C707 10M006 512 .User can visit <http://www.amphenol.com> for more information about the holder.

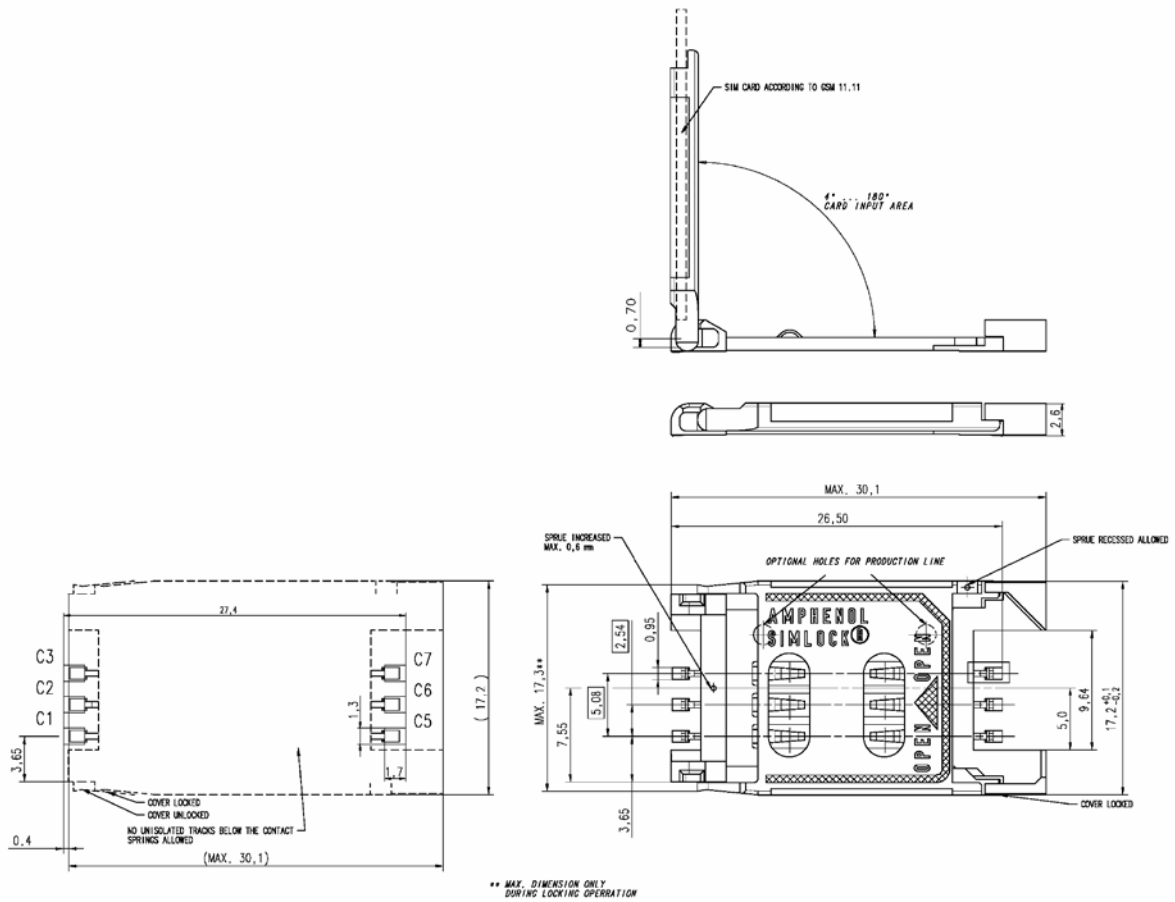

Figure 35: Amphenol C707 10M006 512 SIM card holder

Table 17: Pin description (Amphenol SIM card holder)

Pin name	Signal	Description
C1	SIM_VDD	SIM card power supply
C2	SIM_RST	SIM card reset
C3	SIM_CLK	SIM card clock
C5	GND	Connect to GND
C6	VPP	Not connect
C7	SIM_DATA	SIM card data I/O

4.10. PCM Interface

SIM800 provides PCM interface.

Table 18: PCM pin definition

Pin name	Pin number	Description
PCM_OUT	6	PCM data output
PCM_IN	12	PCM data input
PCM_SYNC	14	PCM synchrony
PCM_CLK	68	PCM clock

SIM800 PCM interface only supports master mode, data length is 16 bits (linear), and PCM clock rate is 256 KHz.

Table 19: PCM Specification

Feature	Specification
Line Interface Format	Linear(Fixed)
Data length	16bits(Fixed)
PCM Clock/Sync Source	Master Mode(Fixed)
PCM Clock Rate	256Khz(Fixed)
PCM Sync Format	Short sync/Long sync both support
Zero Padding/Sign extension	Default Zero Padding
Data Ordering	MSB/LSB both support

Note: User can use AT command control PCM interface, for details please refer to document [1].

4.10.1. PCM Interface

Refer to the following figure for PCM design:

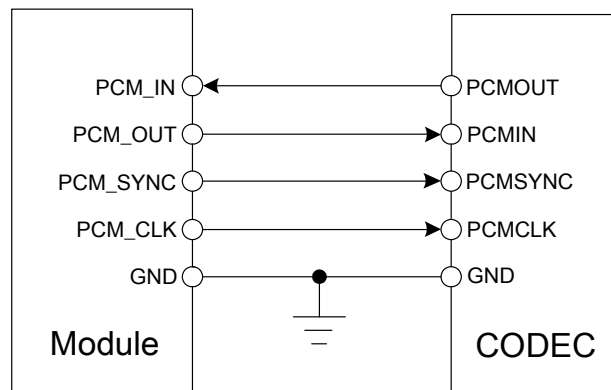

Figure 36: PCM reference circuit

4.11. Keypad Interface

SIM800 consists of 5 keypad column outputs and 5 keypad row inputs, and it can support two kinds of connections, the traditional 5*5 keypad matrix and the extended 5*5*2 keypad matrix.

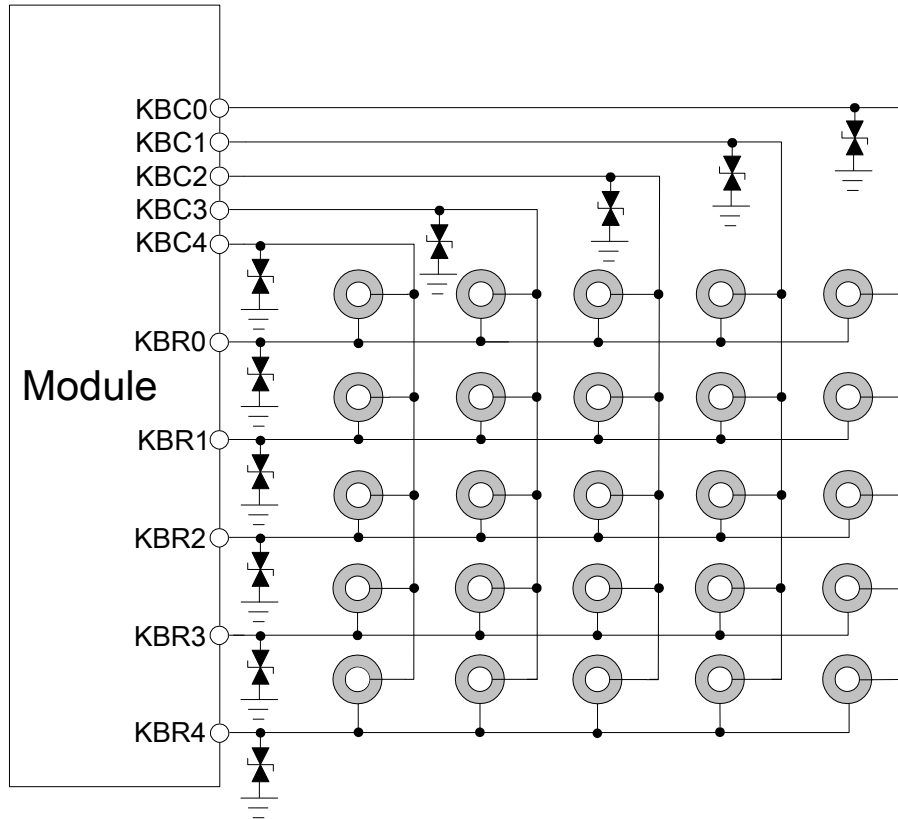

Figure 37: Traditional keypad reference circuit

*Note: According to the traditional 5*5 keypad matrix, when there are unused KBCs or KBRs, user can execute AT command to define unused KBCs and KBRs as GPIO, for details please see the document [1].*

Module supports a new keypad connection, it can support 5*5*2 amount 50 keypads, meet full keyboard demand, and the connection diagram is as follow:

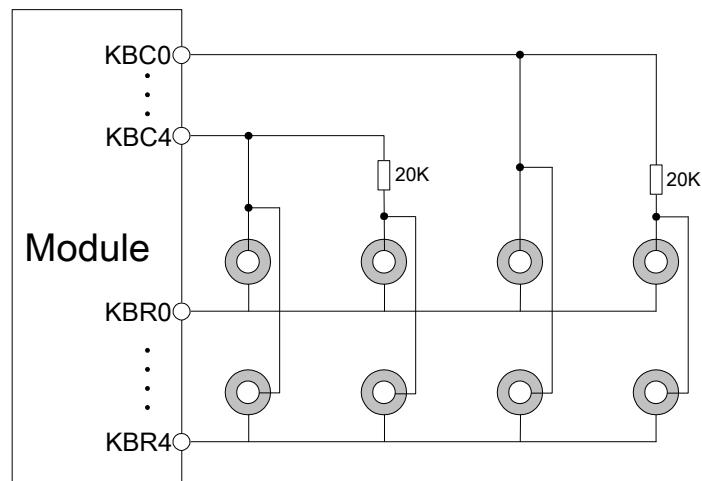

Figure 38: Extended keypad reference circuit

Note: Do not change the 20K Ω resistor in the diagram.

Customer should add a resistor to enhance the ESD performance and the value of resistor should be less than 1K Ω , the connection diagram is shown in figure 41 as an example.

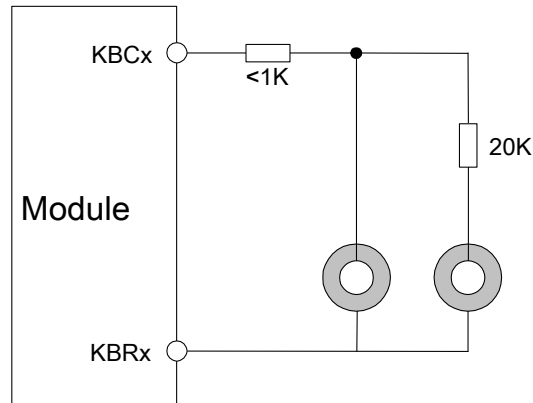

Figure 39: Enhance the ESD performance of keypad circuit

Module can detect two buttons pressed synchronously at both the traditional and extended keypad connection, but customer should notice that, do not assign keys which will be pressed at the same time on same KBC and KBR when implement the extended keypad design. The following figure is an example to explain this situation, “CTRL” and “A” can not be recognized if the two buttons were pressed at the same time.

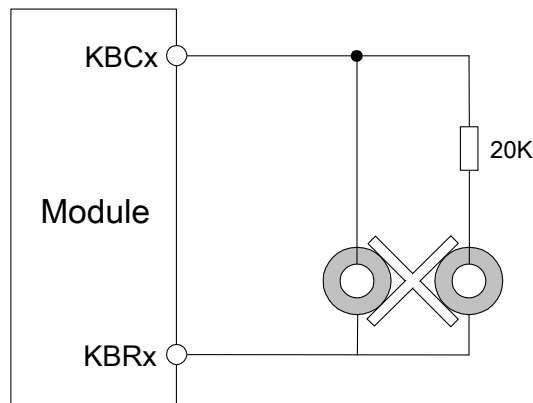

Figure 40: Keypad detected

Table 20: Pin definition of the keypad interface

Name	Pin	Function	Default state
KBC0	51	Keypad matrix column	Pull up
KBC1	50		Pull down
KBC2	49		Pull down
KBC3	48		Pull down
KBC4	47		Pull down
KBR0	44	Keypad matrix row	Pull down
KBR1	43		Pull down
KBR2	42		Pull down
KBR3	41		Pull down
KBR4	40		Pull down

4.12. I2C BUS

The SIM800 provides an I2C interface. It has the following features:

- Compliant master mode operation
- Adjustable clock speed for LS/FS mode operation
- Support 7-bit/10-bit addressing
- Support high speed mode
- Support slave clock extension
- START/STOP/REPEATED condition
- Manual transfer mode
- Multi-write per transfer (up to 8 data bytes for non-DMA mode)
- Multi-read per transfer (up to 8 data bytes for non-DMA mode)
- Multi-transfer per transaction
- Combined format transfer with length change capability
- Active drive/write-and I/O configuration

Table 21: Pin definition of the I2C

Pin name	Pin number	Description
SCL	37	I2C serial bus clock(open drain output)
SDA	38	I2C serial bus data(open drain output)

Note: I2C has been pulled up to 2.8V via 4.7KΩ inside.

4.13. General Purpose Input/Output (GPIO)

SIM800 provides 2 GPIO pins. The output voltage level of the GPIO can be set by the AT command “AT+SGPIO” or “AT+CGPIO”. The input voltage level of the GPIO can also be read by the AT command “AT+SGPIO” or “AT+CGPIO”. For more details, please refer to *document [1]*.

NOTE: *If you use AT+SGPIO,, <GPIO> According to the following mapping*

GPIO17: *<GPIO>=3*

GPIO19: *<GPIO>=2*

The Pin number table in the AT+CGPIO command under <pin> reference

Table 22: Pin definition of the GPIO

Pin name	Pin number	Reset state
GPIO17	11	-
GPIO19	13	-

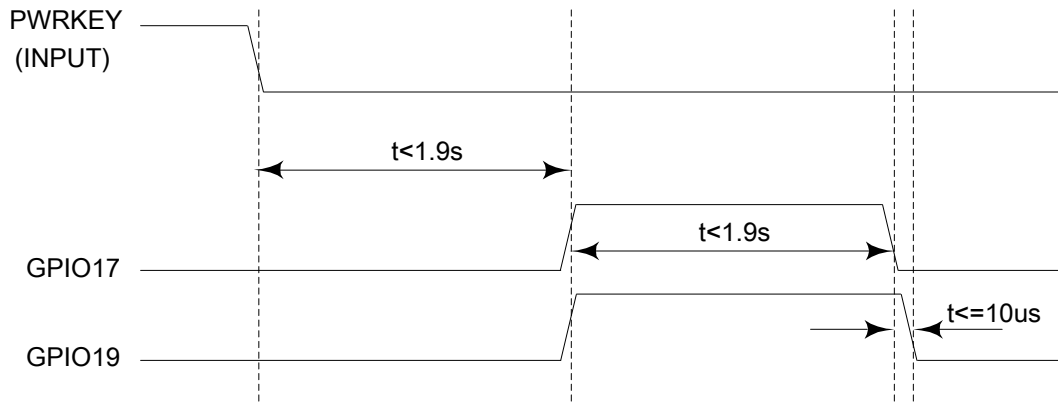
Figure 41: GPIO timing sequences

4.14. ADC

Table 23: Pin definition of the ADC

Pin name	Pin number	Description
ADC	25	Analog to Digital Converter

SIM800 provides an auxiliary ADC, which can be used to measure the voltage. Customer can use AT command “AT+CADC” to read the voltage value. For details of this AT command, please refer to *document [1]*.

Table 24: ADC specification

Parameter	Min	Typ	Max	Unit
Voltage range	0	-	2.8	V
ADC Resolution	-	10	-	bits
Sampling rate	-	-	1.0833	MHz
ADC precision		10	30	mV

Note: the voltage should less than 2.8V, or the ADC may be damaged.

4.15. PWM

Table 25: Pin definition of the PWM

Pin name	Pin number	Description
PWM0	35	PWM0
PWM1	36	PWM1

Note: SIM800 can only support 1 PWM synchronously, if customer set PIN 35 as PWM, so PIN36 can only be used as GPIO.

PWM output frequency varies from 200Hz – 100KHz. Two 7-bit unsigned binary parameters are used for the

output period and for the duty cycle. The AT command “AT + SPWM” is used to set the output period and duty cycle of the PWM. For details, please refer to *document [1]*.

A typical circuit of the PWM drives buzzer is shown in the following figure:

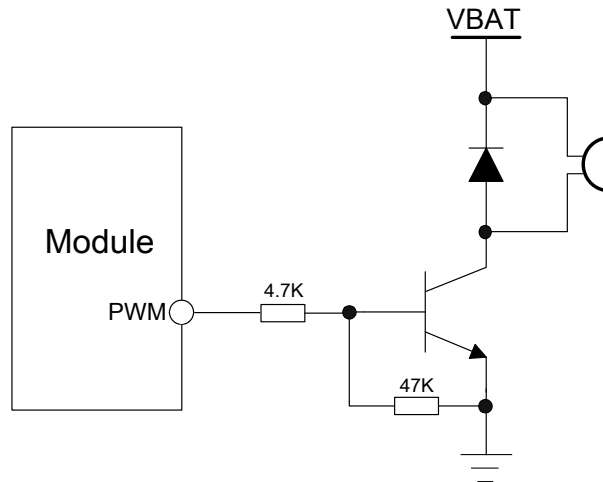

Figure 42: Reference circuit of PWM drive buzzer

Table 26: PWM output characteristics

Parameter	Min	Typ	Max	Unit
Working voltage	2.5	2.8	2.9	V
Working current		4	16	mA

Note: PWM pin must keep low when module in the boot process.

Table 27: PWM multiplex function

Pin name	Pin number	Mode 0(default)	Mode 1
PWM0	35	PWM0	GPIO
PWM1	36	GPIO	PWM1

4.16. Network Status Indication

Table 28: Pin definition of the NETLIGHT

Pin name	Pin number	Description
NETLIGHT	52	Network Status Indication

The NETLIGHT pin can be used to drive a network status indication LED. The status of this pin is listed in following table:

Table 29: Status of the NETLIGHT pin

Status	SIM800 behavior
Off	SIM800 is not running
64ms On/ 800ms Off	SIM800 not registered the network
64ms On/ 3000ms Off	SIM800 registered to the network
64ms On/ 300ms Off	GPRS communication is established

Reference circuit is recommended in the following figure:

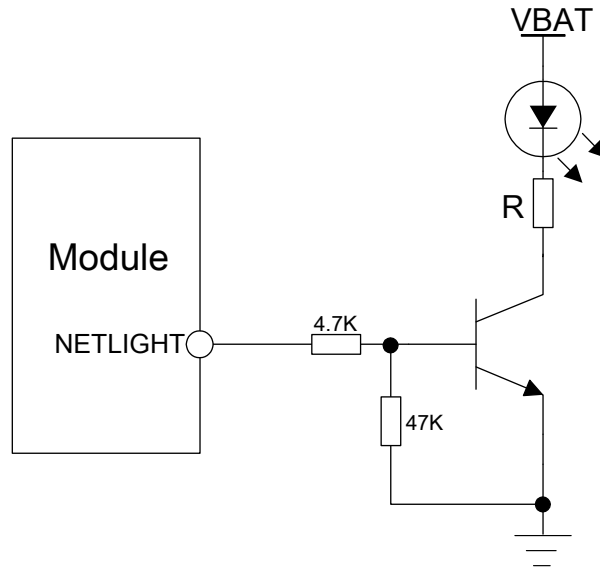

Figure 43: Reference circuit of NETLIGHT

4.17. Operating Status Indication

The STATUS pin indicates the operating status of module. The pin output high when module power on, output is low when module powered off.

Table 30: Pin definition of the STATUS

Pin name	Pin number	Description
STATUS	66	Operating status indication

4.18. KPLED

SIM800 provides one open-drain LED driver pin.

Table 31: Pin definition of the KPLED

Pin name	Pin number	Description
KPLED	23	Sink current for keypad LED

Reference circuit is recommended in the following figure:

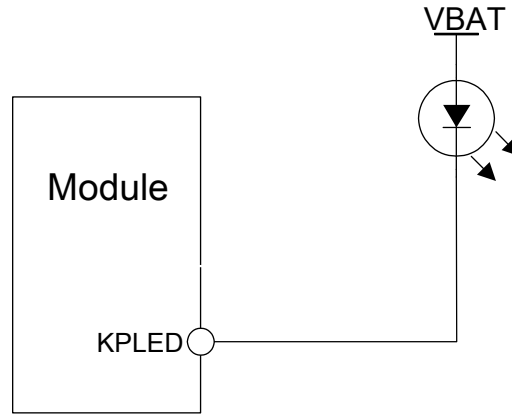

Figure 44: KPLED driver reference circuit

Table 32: KPLED specification

Pin name	Min	Typ	Max	Unit
KPLED		-	60	mA

4.19. RF Synchronization Signal

The synchronization signal serves to indicate growing power consumption during the transmit burst.

Table 33: Definition of the RF_SYNC pin

Pin name	Pin number	Description
RF_SYNC	67	Transmit synchronization signal

Note: Do not pull up RF_SYNC.

The timing of the synchronization signal is shown in the following figure. High level of the RF_SYNC signal indicates increased power consumption during transmission.

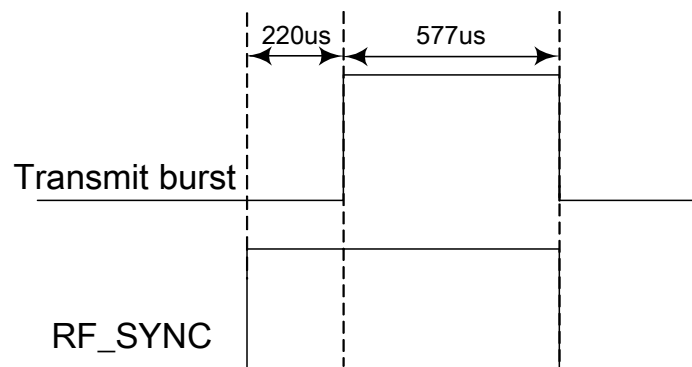

Figure 45: RF_SYNC signal during transmit burst

4.20. Antenna Interface

There are two antenna ports for SIM800, GSM antenna port named GSM_ANT and Bluetooth antenna port named BT_ANT; The RF interfaces of the two antenna ports both have the impedance of 50Ω

- The input impedance of the antenna should be 50Ω, and the VSWR should be less than 2.
- It is recommended that GSM antenna and Bluetooth antenna be placed as far as better.
- The isolations of the two antenna should be more than 30db

NOTE: About the RF trace layout please refer to “AN_SMT Module_RF_Reference_Design_Guide”

4.20.1. GSM Antenna Interface

There is a GSM antenna pad named GSM_ANT to connect a GSM antenna, the connection of the antenna must be decoupled from DC voltage. This is necessary because the antenna connector is DC coupled to ground via an inductor for ESD protection. The GSM antenna must be matched properly to achieve the best performance, so the matching circuit is necessary. For the purpose of static electricity, we recommend to add D101, which is a TVS, the recommendation ESD component as table 38. The connection is recommended as following:

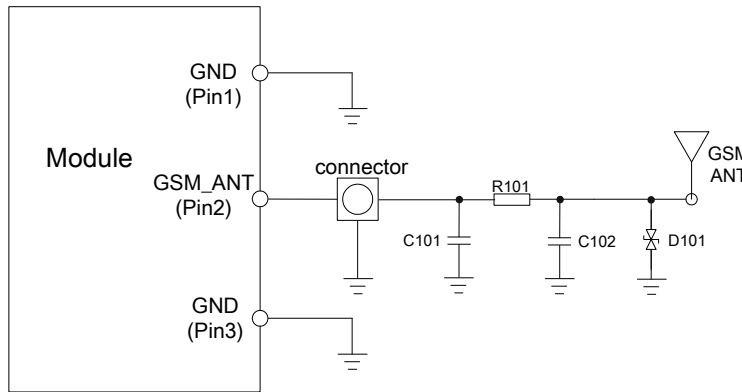

Figure 46: GSM antenna matching circuit

R101, C101, C102 are the matching circuit, the values depend on antenna debug result. Normally R101 is 0Ω, C101 and C102 are not mounted. The RF connector is used for conducted test. If the space between GSM_ANT pin and antenna is not enough, the matching circuit could be simplified as the following figure:

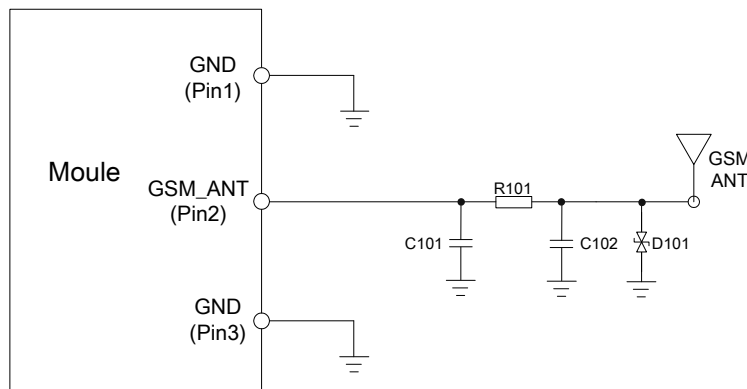

Figure 47: GSM simple antenna matching circuit

For the purpose of static electricity, we recommend to add D101, which is a TVS, the recommendation ESD component as table 38.

Normally R101 is 0Ω; C101 and C102 are not mounted.

Table 34: Recommendation of ESD component

package	model	supplier
0201	LXES03AAA1-154	MuRata
0402	LXES15AAA1-153	MuRata

4.20.2. Bluetooth Antenna Interface

The module provides a Bluetooth antenna interface named BT_ANT to connect a Bluetooth antenna. The Bluetooth antenna must be matched properly to achieve best performance, so the matching circuit is necessary, the connection is recommended as the following figure:

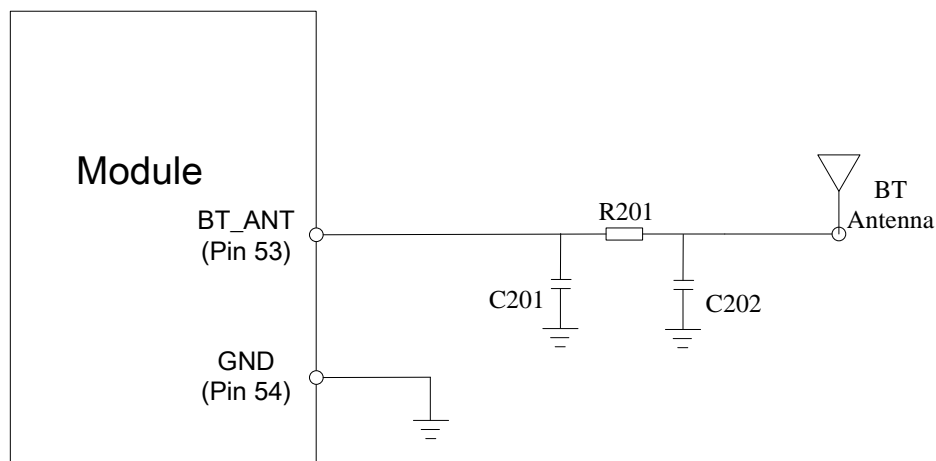
Figure 48: Bluetooth antenna matching circuit

R201, C201, C202 are the matching circuit, the values depend on antenna debug result. Normally R201 is 0Ω , C201 and C202 are not mounted.

5. PCB Layout

Usually, most electronic products with good performance are based on good PCB layout. Poor PCB layout will lead to lots of issues, like TDD noise, SIM card undetected, etc. The final solution for these problems is to redesign PCB layout. Making good PCB layout will save developing schedule and cost as well.

This section will give some guidelines on PCB layout, in order to eliminate interfere or noise by greatest degree, and save product development period.

5.1 PIN Assignment

Before the placement of the PCB design, customer should learn well about PIN assignment in order to get reasonable layout with so many external components. Please refer to figure 2 for the details.

5.2 Principle of PCB Layout

During layout, we should pay attention to the following interfaces, like Antenna, power supply, SIM card interface, audio interface, and so on.

5.2.1 Antenna

There are some suggestions for components placing and routing of GSM and Bluetooth RF traces:

- The RF connector is used for conducted test, so keep it as close to the GSM_ANT pin as possible;
- Antenna matching circuit should be closed to the antenna;
- Keep the RF traces as 50Ω;
- The RF traces should be kept far away from the high speed signals and strong disturbing source.
- If using a RF cable, kept it far away from SIM card, power ICs;

It is recommended that GSM antenna and Bluetooth antenna be placed as far as better.

5.2.2. Power Supply

Not only VBAT but also power ground is very important in layout. The positive line of VBAT should be as shorter and wider as possible. The correct flow from source to VBAT pin should go though Zener diode then huge capacitor. PIN 62, 63, 64, 65 are GND signals, and should be designed shortest layout to GND of power source.

5.2.3 SIM Card Interface

SIM card holder will take much more space on board, and there has no anti-EMI component inside, so, SIM card interface always be interfered. So, pay attention to this interface during layout. Ensure SIM card holder far way from antenna or RF cable. And it's better to put SIM card holder near module, And it's better to add ESD component to protect clock, data, reset and SIM_VDD signals which should be far away from power and high-speed signal.

5.2.4 Audio Interface

In order to avoid TDD noise, or current noise, or some other noise, the signal trace of audio should far away from antenna and power, and it is recommended to surround audio traces by ground. And do not rout audio trace and VBAT trace parallel.

5.2.5 Others

It's better to trace signal lines of UART bunched, as well as signals of USB .

5.3 Recommended PCB Layout

Based on above principles, recommended layout is shown in the following illustration.

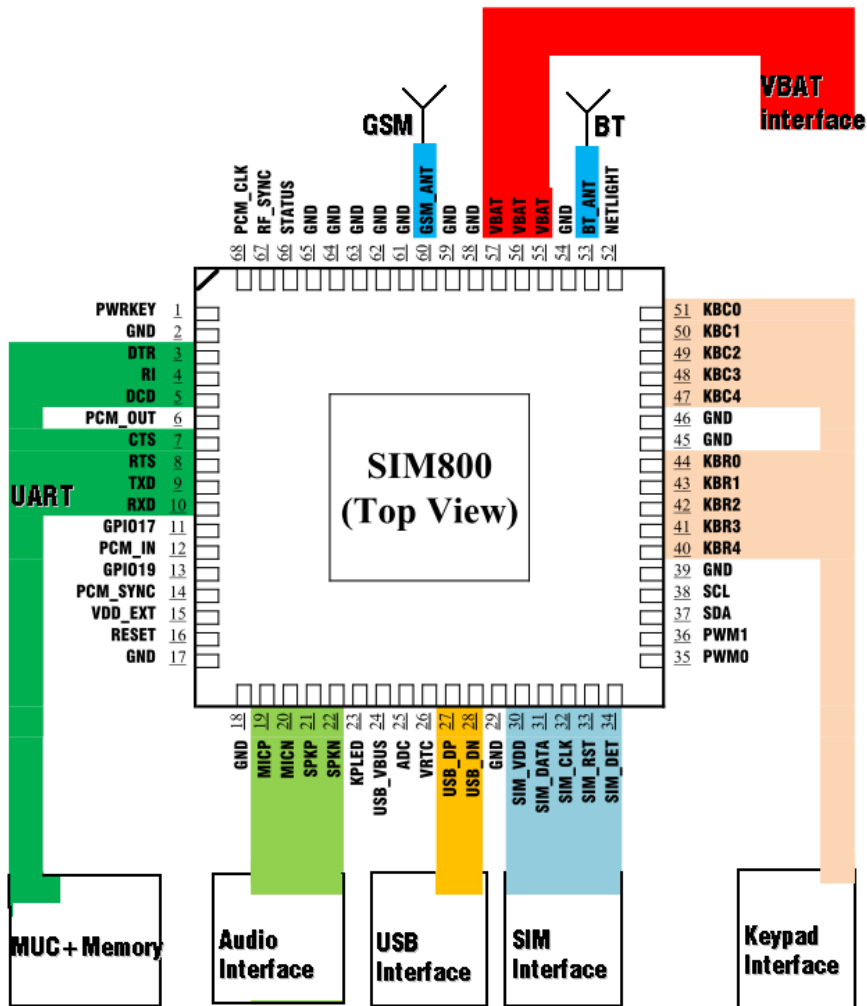

Figure 49: Recommended PCB layout

6. Electrical, Reliability and Radio Characteristics

6.1 Absolute Maximum Ratings

The absolute maximum ratings stated in following table are stress ratings under non-operating conditions. Stresses beyond any of these limits will cause permanent damage to SIM800.

Table 35: Absolute maximum ratings

Symbol	Min	Typ	Max	Unit
V _{BAT}	-	-	4.5	V
Peak Current	0	-	2.0	A
USB_VBUS	-	-	12	V
I _I *	-	4		mA
I _O *	-	4		mA

These parameters are for digital interface pins, such as keypad, GPIO, I2C, UART, LCD and PCM.

6.2 Recommended Operating Conditions

Table 36: Recommended operating conditions

Symbol	Parameter	Min	Typ	Max	Unit
V _{BAT}	Power supply voltage	3.4	4.0	4.4	V
T _{OPER}	Operating temperature	-40	+25	+85	°C
T _{STG}	Storage temperature	-45		+90	°C

6.3 Digital Interface Characteristics

Table 37: Digital interface characteristics

Symbol	Parameter	Min	Typ	Max	Unit
V _{IH}	High-level input voltage	2.1	-	3.0	V
V _{IL}	Low-level input voltage	-0.3	-	0.7	V
V _{OH}	High-level output voltage	2.4	-	-	V
V _{OL}	Low-level output voltage	-	-	0.4	V

* These parameters are for digital interface pins, such as keypad, GPIO, I2C, UART, and PCM.

6.4 SIM Card Interface Characteristics

Table 38: SIM card interface characteristic

Symbol	Parameter	Min	Typ	Max	Unit
I_{IH}	High-level input current	-1	-	1	μA
I_{IL}	Low-level input current	-1	-	1	μA
V_{IH}	High-level input voltage	1.4	-	-	V
		2.4	-	-	V
V_{IL}	Low-level input voltage	-	-	0.27	V
		-	-	0.4	V
V_{OH}	High-level output voltage	1.62	-	-	V
		2.7	-	-	V
V_{OL}	Low-level output voltage	-	-	0.36	V
		-	-	0.4	V

6.5 SIM_VDD Characteristics

Table 39: SIM_VDD characteristics

Symbol	Parameter	Min	Typ	Max	Unit
V_O	Output voltage	-	3.0	-	V
		-	1.8	-	
I_O	Output current	-	-	10	mA

6.6 VDD_EXT Characteristics

Table 40: VDD_EXT Characteristics

Symbol	Parameter	Min	Typ	Max	Unit
V_O	Output voltage	2.7	2.8	2.9	V
I_O	Output current	-	-	50	mA

6.7 VRTC Characteristics

Table 41: VRTC Characteristics

Symbol	Description	Min	Typ	Max	Unit
V_{RTC-IN}	VRTC input voltage	1.2	2.8	3.0	V
I_{RTC-IN}	VRTC input current	-	3.0	-	μA
$V_{RTC-OUT}$	VRTC output voltage	-	2.8	-	V
$I_{RTC-OUT}$	VRTC output current	-	-	2.0	mA

6.8 Current Consumption (VBAT=4V)

Table 42: Current consumption

Symbol	Parameter	Conditions	Min	Typ	Max	Unit
VBAT	Voltage		3.4	4.0	4.4	V
	Power drop	PCL=5			350	mV
	Voltage ripple	PCL=5 @ f<200kHz @ f>200kHz			50 2.0	mV
I _{VBAT}	Average current	Power off mode		150		uA
		Sleep mode (AT+CFUN=1): (BS-PA-MFRMS=9) (BS-PA-MFRMS=5) (BS-PA-MFRMS=2)		1.2 1.3 2.0		mA
		Idle mode (AT+CFUN=1): EGSM900		22.1		mA
		Voice call (PCL=5): GSM850 EGSM900 DCS1800 PCS1900		204.8 203.9 133.1 137.9		mA
		Data mode GPRS (1Rx,4Tx): GSM850 EGSM900 DCS1800 PCS1900		450.9 457.3 281.8 288.4		mA
		Data mode GPRS (3Rx,2Tx): GSM850 EGSM900 DCS1800 PCS1900		386.1 345.0 216.8 239.1		mA
		Data mode GPRS (4Rx,1Tx): GSM850 EGSM900 DCS1800 PCS1900		217.8 217.9 156.4 159.8		mA
		I _{MAX}	Peak current	During TX burst		

* In above table the current consumption value is the typical one of the module tested in laboratory. In the mass production stage, there may be differences among each individual.

6.9 Electro-Static Discharge

SIM800 is an ESD sensitive component, so more attention should be paid to the procedure of handling and packaging. The ESD test results are shown in the following table.

Table 43: The ESD characteristics (Temperature: 25°C, Humidity: 45 %)

Pin name	Contact discharge	Air discharge
VBAT	±5KV	±10KV
GND	±5KV	±10KV
RXD, TXD	±4KV	±8KV
GSM_ANT	±5KV	±10KV
SPKP/SPKN/MICP/MICN	±4KV	±8KV
PWRKEY	±4KV	±8KV

6.10 Radio Characteristics

The following table shows the module conducted output power, it is followed by the 3GPP TS 05.05 technical specification requirement.

Table 44: GSM 900 and GSM 850 conducted RF output power

GSM850,EGSM900			
PCL	Nominal output power (dBm)	Tolerance (dB) for conditions	
		Normal	Extreme
5	33	±2	±2.5
6	31	±3	±4
7	29	±3	±4
8	27	±3	±4
9	25	±3	±4
10	23	±3	±4
11	21	±3	±4
12	19	±3	±4
13	17	±3	±4
14	15	±3	±4
15	13	±3	±4
16	11	±5	±6
17	9	±5	±6
18	7	±5	±6
19-31	5	±5	±6

Table 45: DCS 1800 and PCS 1900 conducted RF output power

DCS1800,PCS1900			
PCL	Nominal output power (dBm)	Tolerance (dB) for conditions	
		Normal	Extreme
0	30	±2	±2.5
1	28	±3	±4
2	26	±3	±4
3	24	±3	±4
4	22	±3	±4
5	20	±3	±4
6	18	±3	±4
7	16	±3	±4
8	14	±3	±4
9	12	±4	±5
10	10	±4	±5
11	8	±4	±5
12	6	±4	±5
13	4	±4	±5
14	2	±5	±6
15	0	±5	±6

6.11 Module RF Receive Sensitivity

The following table shows the SIM800 conducted receive sensitivity; it is tested under static condition.

Table 46: Conducted RF receive sensitivity

Frequency	Receive sensitivity(Typical)	Receive sensitivity(Max)
GSM850,EGSM900	< -108dBm	< -106dBm
DCS1800,PCS1900	< -108dBm	< -106dBm

6.12 Module Operating Frequencies

The following table shows the module's operating frequency range; it is followed by the 3GPP TS 05.05 technical specification requirement.

Table 47: Operating frequencies

Frequency	Receive	Transmit	Channel
GSM850	869 ~ 894MHz	824 ~ 849MHz	128 ~ 251
EGSM900	925 ~ 960MHz	880 ~ 915MHz	0 ~ 124 , 975 ~ 1023
DCS1800	1805 ~ 1880MHz	1710 ~ 1785MHz	512 ~ 885
PCS1900	1930 ~ 1990MHz	1850 ~ 1910MHz	512 ~ 810

7. Manufacturing

7.1. Top and Bottom View of SIM800



Figure 50: Top and Bottom View of SIM800

7.2. Typical Solder Reflow Profile

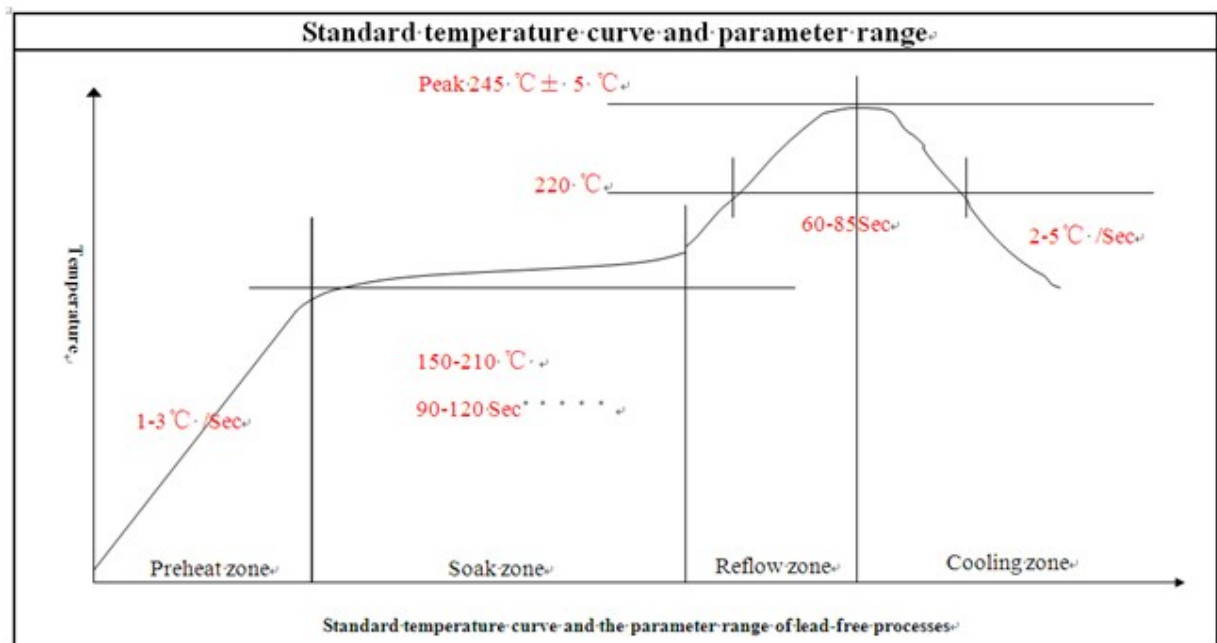

Figure 51: Typical Solder Reflow Profile

Note: Please refer to “Module secondary-SMT-UGD” for more information about the module shipping and manufacturing.

7.3. The Moisture Sensitivity Level

The moisture sensitivity level of SIM800 is 3. The module should be mounted within 168 hours after unpacking in the environmental conditions of temperature $<30^{\circ}\text{C}$ and relative humidity of $<60\%$ (RH). It is necessary to bake the module if the above conditions are not met:

Table 48: Moisture classification level and floor life

Level	Floor Life (out of bag) at factory ambient $\leq 30^{\circ}\text{C}$ /60% RH or as stated
1	Unlimited at $\leq 30^{\circ}\text{C}$ /85% RH
2	1 year
2a	4 weeks
3	168 hours
4	72 hours
5	48 hours
5a	24 hours
6	Mandatory bake before use. After bake, it must be reflowed within the time limit specified on the label.

NOTES:

- 1. If the vacuum package is not open for 6 months or longer than the packing date, baking is also recommended before re-flow soldering.*
- 2. For product handling, storage, processing, IPC / JEDEC J-STD-033 must be followed.*

7.4. Baking Requirements

Because of its sensitivity to moisture absorption, SIM800 should be baked sufficiently before re-flow soldering. Otherwise SIM800 will be at the risk of permanent damage during re-flow soldering. SIM800 should be baked 192 hours at temperature $40^{\circ}\text{C} \pm 5^{\circ}\text{C} / -0^{\circ}\text{C}$ and $<5\%$ RH for low-temperature device containers, or 72 hours at temperature $80^{\circ}\text{C} \pm 5^{\circ}\text{C}$ for high-temperature device containers. Care should be taken that the plastic tray is not heat resistant, SIM800 modules should be taken out for baking, and otherwise the tray may be damaged by high-temperature during baking.

Table 49: Baking requirements

Baking temperature	Moisture	Time
$40^{\circ}\text{C} \pm 5^{\circ}\text{C}$	$<5\%$	192 hours
$120^{\circ}\text{C} \pm 5^{\circ}\text{C}$	$<5\%$	4 hours

8. Packaging

Module support tray packaging.

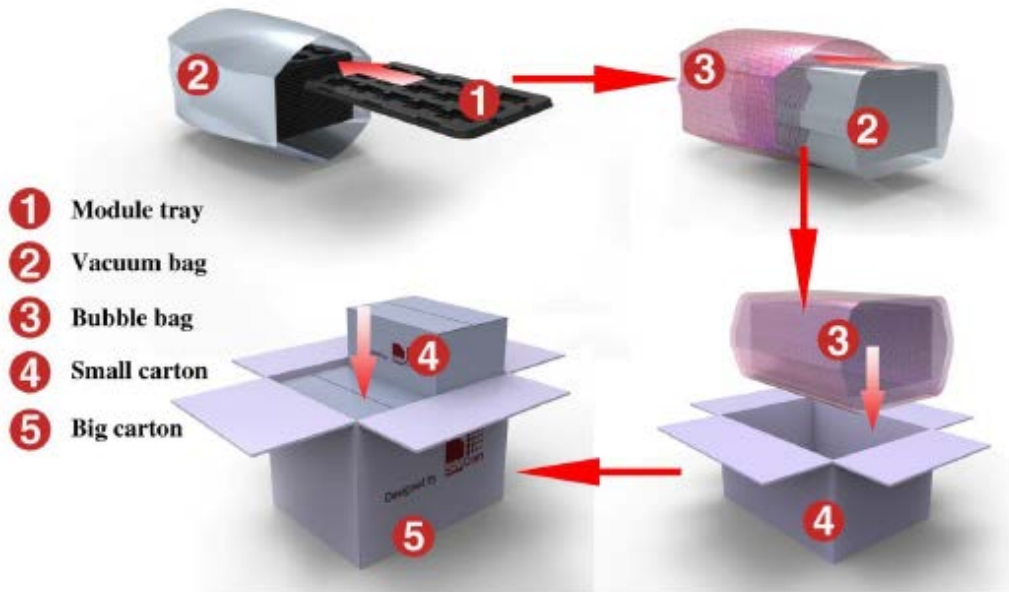

Figure 52: packaging diagram

Module tray drawing:

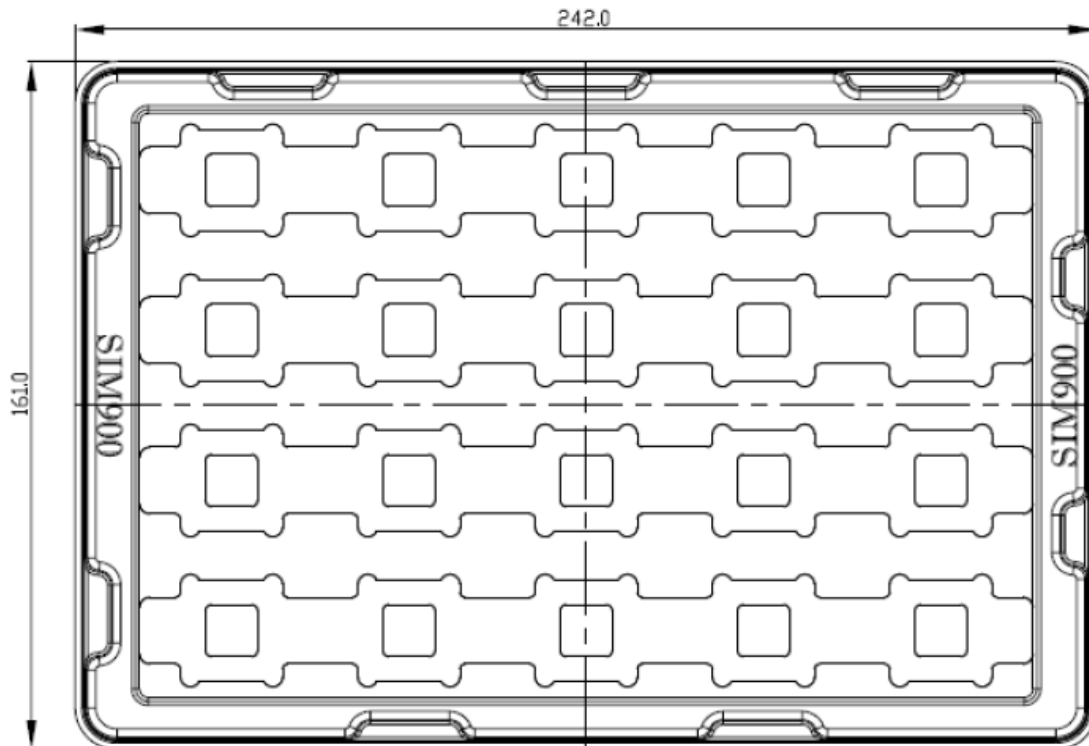

Figure 53: Tray drawing

Table 50: Tray size

Length ($\pm 3\text{mm}$)	Width ($\pm 3\text{mm}$)	Number
242.0	161.0	20

Small carton drawing:

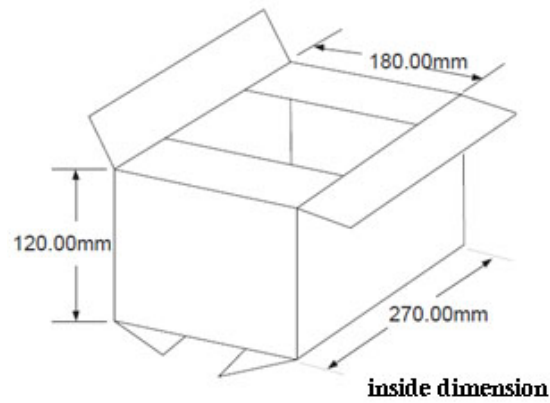

Figure 54: Small carton drawing

Table 51: Small Carton size

Length ($\pm 10\text{mm}$)	Width ($\pm 10\text{mm}$)	Height ($\pm 10\text{mm}$)	Number
270	180	120	20*20=400

Big carton drawing:

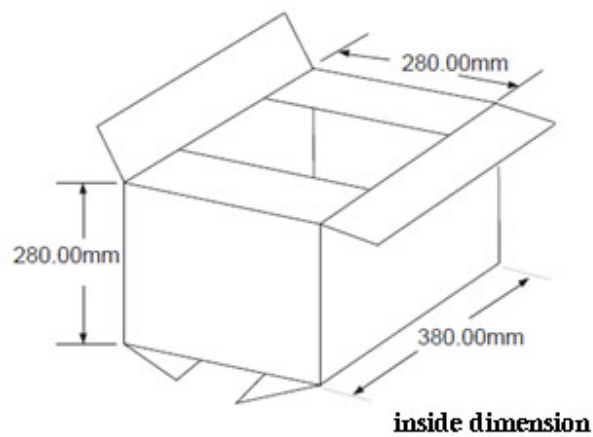

Figure 55: Big carton drawing

Table 52: Big Carton size

Length ($\pm 10\text{mm}$)	Width ($\pm 10\text{mm}$)	Height ($\pm 10\text{mm}$)	Number
380	280	280	400*4=1600

9. Appendix

I. Related Documents

Table 53: Related Documents

SN	Document name	Remark
[1]	SIM800 Series_AT Command Manual	
[2]	ITU-T Draft new recommendation V.25ter:	Serial asynchronous automatic dialing and control
[3]	GSM 07.07:	Digital cellular telecommunications (Phase 2+); AT command set for GSM Mobile Equipment (ME)
[4]	GSM 07.10:	Support GSM 07.10 multiplexing protocol
[5]	GSM 07.05:	Digital cellular telecommunications (Phase 2+); Use of Data Terminal Equipment – Data Circuit terminating Equipment (DTE – DCE) interface for Short Message Service (SMS) and Cell Broadcast Service (CBS)
[6]	GSM 11.14:	Digital cellular telecommunications system (Phase 2+); Specification of the SIM Application Toolkit for the Subscriber Identity Module – Mobile Equipment (SIM – ME) interface
[7]	GSM 11.11:	Digital cellular telecommunications system (Phase 2+); Specification of the Subscriber Identity Module – Mobile Equipment (SIM – ME) interface
[8]	GSM 03.38:	Digital cellular telecommunications system (Phase 2+); Alphabets and language-specific information
[9]	GSM 11.10	Digital cellular telecommunications system (Phase 2); Mobile Station (MS) conformance specification; Part 1: Conformance specification
[10]	AN_Serial Port	AN_Serial Port
[11]	AN_SIM900_TCPIP	TCP/IP Applications User Manual
[12]	Module secondary-SMT-UGD	
[13]	AN_SMT Module_RF_Reference Design_Guide	
[14]	SIM800_EVB kit_User Guide	

II. Terms and Abbreviations







Table 54: Terms and Abbreviations

Abbreviation	Description
ADC	Analog-to-Digital Converter
AMR	Adaptive Multi-Rate
BT	Bluetooth
CS	Coding Scheme
CSD	Circuit Switched Data
CTS	Clear to Send
DTE	Data Terminal Equipment (typically computer, terminal, printer)
DTR	Data Terminal Ready
DTX	Discontinuous Transmission
EFR	Enhanced Full Rate
EGSM	Enhanced GSM
ESD	Electrostatic Discharge
ETS	European Telecommunication Standard
FR	Full Rate
GPRS	General Packet Radio Service
GSM	Global Standard for Mobile Communications
HR	Half Rate
IMEI	International Mobile Equipment Identity
Li-ion	Lithium-Ion
MO	Mobile Originated
MS	Mobile Station (GSM engine), also referred to as TE
MT	Mobile Terminated
PAP	Password Authentication Protocol
PBCCH	Packet Broadcast Control Channel
PCB	Printed Circuit Board
PCL	Power Control Level
PCS	Personal Communication System, also referred to as GSM 1900
PDU	Protocol Data Unit
PPP	Point-to-point protocol
RF	Radio Frequency
RMS	Root Mean Square (value)
RTC	Real Time Clock
RX	Receive Direction
SIM	Subscriber Identification Module
SMS	Short Message Service
TDD	Time Division Distortion
TE	Terminal Equipment, also referred to as DTE

TX	Transmit Direction
UART	Universal Asynchronous Receiver & Transmitter
URC	Unsolicited Result Code
USSD	Unstructured Supplementary Service Data
VSWR	Voltage Standing Wave Ratio
Phonebook abbreviations	
FD	SIM fix dialing phonebook
LD	SIM last dialing phonebook (list of numbers most recently dialed)
MC	Mobile Equipment list of unanswered MT calls (missed calls)
ON	SIM (or ME) own numbers (MSISDNs) list
RC	Mobile Equipment list of received calls
SM	SIM phonebook
NC	Not connect

III.Safety Caution

Table 55: Safety caution

Marks	Requirements
	When in a hospital or other health care facility, observe the restrictions about the use of mobiles. Switch the cellular terminal or mobile off, medical equipment may be sensitive to not operate normally for RF energy interference.
	Switch off the cellular terminal or mobile before boarding an aircraft. Make sure it is switched off. The operation of wireless appliances in an aircraft is forbidden to prevent interference with communication systems. Forget to think much of these instructions may lead to the flight safety or offend against local legal action, or both.
	Do not operate the cellular terminal or mobile in the presence of flammable gases or fumes. Switch off the cellular terminal when you are near petrol stations, fuel depots, chemical plants or where blasting operations are in progress. Operation of any electrical equipment in potentially explosive atmospheres can constitute a safety hazard.
	Your cellular terminal or mobile receives and transmits radio frequency energy while switched on. RF interference can occur if it is used close to TV sets, radios, computers or other electric equipment.
	Road safety comes first! Do not use a hand-held cellular terminal or mobile when driving a vehicle, unless it is securely mounted in a holder for hands free operation. Before making a call with a hand-held terminal or mobile, park the vehicle.
	<p>GSM cellular terminals or mobiles operate over radio frequency signals and cellular networks and cannot be guaranteed to connect in all conditions, for example no mobile fee or a invalid SIM card. While you are in this condition and need emergent help, please remember using emergency calls. In order to make or receive calls, the cellular terminal or mobile must be switched on and in a service area with adequate cellular signal strength.</p> <p>Some networks do not allow for emergency call if certain network services or phone features are in use (e.g. lock functions, fixed dialing etc.). You may have to deactivate those features before you can make an emergency call.</p> <p>Also, some networks require that a valid SIM card be properly inserted in the cellular terminal or mobile.</p>

Contact us:

Shanghai SIMCom Wireless Solutions Ltd.

Address: Building B, No.633 Jinzhong Road, Changning District, Shanghai

P.R.China 200335

Tel: +86 21 3157 5100\3157 5200

Email: simcom@simcom.com, simcom@sim.com

Website: www.simcomm2m.com