



SIM7906E-PCIE Series Hardware Design

LTE Module

SIMCom Wireless Solutions Limited

Building B, SIM Technology Building, No.633, Jinzhong Road
Changning District, Shanghai P.R. China

Tel: 86-21-31575100

support@simcom.com

www.simcom.com

Document Title:	SIM7906E-PCIE Series Hardware Design
Version:	V1.03
Date:	2020-12-07
Status:	Released

GENERAL NOTES

SIMCOM OFFERS THIS INFORMATION AS A SERVICE TO ITS CUSTOMERS, TO SUPPORT APPLICATION AND ENGINEERING EFFORTS THAT USE THE PRODUCTS DESIGNED BY SIMCOM. THE INFORMATION PROVIDED IS BASED UPON REQUIREMENTS SPECIFICALLY PROVIDED TO SIMCOM BY THE CUSTOMERS. SIMCOM HAS NOT UNDERTAKEN ANY INDEPENDENT SEARCH FOR ADDITIONAL RELEVANT INFORMATION, INCLUDING ANY INFORMATION THAT MAY BE IN THE CUSTOMER'S POSSESSION. FURTHERMORE, SYSTEM VALIDATION OF THIS PRODUCT DESIGNED BY SIMCOM WITHIN A LARGER ELECTRONIC SYSTEM REMAINS THE RESPONSIBILITY OF THE CUSTOMER OR THE CUSTOMER'S SYSTEM INTEGRATOR. ALL SPECIFICATIONS SUPPLIED HEREIN ARE SUBJECT TO CHANGE.

COPYRIGHT

THIS DOCUMENT CONTAINS PROPRIETARY TECHNICAL INFORMATION WHICH IS THE PROPERTY OF SIMCOM WIRELESS SOLUTIONS LIMITED. COPYING, TO OTHERS AND USING THIS DOCUMENT, ARE FORBIDDEN WITHOUT EXPRESS AUTHORITY BY SIMCOM. OFFENDERS ARE LIABLE TO THE PAYMENT OF INDEMNIFICATIONS. ALL RIGHTS RESERVED BY SIMCOM IN THE PROPRIETARY TECHNICAL INFORMATION, INCLUDING BUT NOT LIMITED TO REGISTRATION GRANTING OF A PATENT, A UTILITY MODEL OR DESIGN. ALL SPECIFICATION SUPPLIED HEREIN ARE SUBJECT TO CHANGE WITHOUT NOTICE AT ANY TIME.

SIMCom Wireless Solutions Limited

Building B, SIM Technology Building, No.633 Jinzhong Road, Changning District, Shanghai P.R.China
Tel: +86 21 31575100
Email: simcom@simcom.com

For more information, please visit:

<https://www.simcom.com/download/list-863-en.html>

For technical support, or to report documentation errors, please visit:

<https://www.simcom.com/ask/> or email to: support@simcom.com

Copyright © 2020 SIMCom Wireless Solutions Limited All Rights Reserved.

Version History

Date	Version	Description of change	Author
2019-11-07	V1.01	Original	Ma Hong Gang Ding Mingfeng
2020-03-24	V1.02	Update document template	Gan Wenke
2020-12-07	V1.03	Modify RF connector	Gan Wenke

Contents

Version History	3
Contents	4
Table Index	6
Figure Index	7
1 Introduction	8
1.1 Product Outline.....	8
1.2 Hardware Interface Overview.....	9
1.3 Hardware Block Diagram.....	2
1.4 Functional Overview.....	2
2 Package Information	4
2.1 Pin Assignment Overview.....	4
2.2 PCI Express Mini Card Connector Pin Description.....	4
2.3 Package Dimensions.....	8
3 Interface Application	9
3.1 Power Supply.....	9
3.2 PERST#.....	9
3.3 W_DISABLE#.....	10
3.4 LED_WWAN#.....	11
3.5 WAKE#.....	11
3.6 USB 2.0.....	13
3.6.1 USB Application Guide.....	13
3.7 USIM Interface.....	14
3.7.1 USIM Application Guide.....	15
3.8 UART Interface.....	16
3.8.1 UART Application Guide.....	16
3.8.2 RI Behavior.....	18
3.9 I2C Interface.....	19
3.9.1 I2C Application Guide.....	20
3.10 PCIe interface.....	21
3.11 PCM and Analog Audio Interface.....	21
3.11.1 PCM Interface.....	21
3.11.2 PCM timing.....	22
3.11.3 PCM Application Guide.....	25
3.11.4 Analog Audio Interface.....	25
4 Antenna Interface	28
4.1 WCDMA/LTE Operating Frequency.....	28
4.2 GNSS Operating Frequency.....	29

4.3	Antenna Installation.....	29
4.3.1	Antenna Requirements.....	29
4.3.2	Recommended RF Connector for Antenna Installation.....	30
5	Electrical Specification.....	32
5.1	Absolute Maximum Ratings.....	32
5.2	Recommended Operating Conditions.....	32
5.3	Operating Mode.....	33
5.3.1	Operating Mode.....	33
5.3.2	Sleep mode.....	34
5.3.3	Minimum functionality mode.....	34
5.4	Current Consumption.....	35
5.5	RF Output Power.....	36
5.6	Conducted Receive Sensitivity.....	37
5.7	ESD.....	38
6	Top and Borrom Voew of Module.....	39
7	Appendix.....	40
7.1	Coding Schemes and Maximum Net Data Rates over Air Interface.....	40
7.2	Related Documents.....	42
7.3	Terms and Abbreviations.....	44
7.4	Safety Caution.....	46

Table Index

TABLE 1: SIM7906E-PCIE SERIES FREQUENCY BANDS.....	8
TABLE 2: HARDWARE INTERFACE FUNCTION.....	9
TABLE 3: HARDWARE INTERFACE DEFINITIONS.....	9
TABLE 4: SIM7906E-PCIE KEY FEATURES.....	2
TABLE 5: PCI EXPRESS MINI CARD CONNECTOR PIN DESCRIPTION.....	4
TABLE 6: RECOMMENDED POWER SUPPLY CHARACTERISTICS.....	9
TABLE 7: PERST# PIN ELECTRONIC CHARACTERISTIC.....	10
TABLE 8: W_DISABLE# PIN STATUS.....	10
TABLE 9: W_DISABLE# PIN ELECTRICAL CHARACTERISTIC.....	10
TABLE 10: NETWORK STATUS INDICATION LED STATUS.....	11
TABLE 11: USIM ELECTRONIC CHARACTERISTIC IN 1.8V MODE (USIM_VDD =1.8V).....	14
TABLE 12: USIM ELECTRONIC CHARACTERISTIC 2.85V MODE (USIM_VDD =2.85V).....	15
TABLE 13: UART ELECTRICAL CHARACTERISTIC.....	17
TABLE 14: I2C ELECTRICAL CHARACTERISTIC.....	20
TABLE 15: PCM SPECIFICATION.....	22
TABLE 16: PCM DC CHARACTERISTICS.....	22
TABLE 17: PCM TIMING PARAMETERS (2G/3G MODE).....	23
TABLE 18: PCM TIMING PARAMETERS (4G MODE).....	24
TABLE 19: MIC INPUT CHARACTERISTICS.....	25
TABLE 20: AUDIO OUTPUT CHARACTERISTICS.....	25
TABLE 21: SIM7906E-PCIE WCDMA/LTE OPERATING FREQUENCIES.....	28
TABLE 22: GNSS OPERATING FREQUENCIES.....	29
TABLE 23: RECOMMENDED WCDMA/LTE ANTENNA CHARACTERISTICS.....	29
TABLE 24: RECOMMENDED GNSS ANTENNA CHARACTERISTICS.....	29
TABLE 25: THE MAJOR SPECIFICATIONS OF THE RF CONNECTOR.....	31
TABLE 26: ABSOLUTE MAXIMUM RATINGS.....	32
TABLE 27: OPERATING CONDITIONS.....	32
TABLE 28: OPERATING TEMPERATURE.....	32
TABLE 29: OPERATING MODE.....	33
TABLE 30: CURRENT CONSUMPTION (VCC =3.3V).....	35
TABLE 31: CONDUCTED OUTPUT POWER.....	36
TABLE 32: SIM7906E-PCIE CONDUCTED RF RECEIVING SENSITIVITY.....	37
TABLE 33: THE ESD PERFORMANCE MEASUREMENT TABLE (TEMPERATURE: 25°C , HUMIDITY: 45%).....	38
TABLE 34: CODING SCHEMES AND MAXIMUM NET DATA RATES OVER AIR INTERFACE.....	40
TABLE 35: RELATED DOCUMENTS.....	42
TABLE 36: TERMS AND ABBREVIATIONS.....	44
TABLE 37: SAFETY CAUTION.....	46

Figure Index

FIGURE 1: SIM7906E-PCIE BLOCK DIAGRAM.....	2
FIGURE 2: SIM7906E-PCIE PIN ASSIGNMENT OVERVIEW.....	4
FIGURE 3: DIMENSIONS OF SIM7906E-PCIE (UNIT: MM).....	8
FIGURE 4: PERST# REFERENCE CIRCUIT.....	9
FIGURE 5: W_DISABLE# REFERENCE CIRCUIT.....	10
FIGURE 6: LED_WWAN# REFERENCE CIRCUIT.....	11
FIGURE 7: WAKE# BEHAVIOUR.....	12
FIGURE 8: WAKE# BEHAVIOUR AS A CALLER.....	12
FIGURE 9: WAKE# REFERENCE CIRCUIT.....	13
FIGURE 10: USB REFERENCE CIRCUIT.....	14
FIGURE 11: USIM INTERFACE REFERENCE CIRCUIT WITH DETECTION FUNCTION.....	15
FIGURE 12: USIM INTERFACE REFERENCE CIRCUIT.....	16
FIGURE 13: UART FULL MODE.....	17
FIGURE 14: UART NULL MODE.....	17
FIGURE 15: REFERENCE CIRCUIT OF LEVEL SHIFT.....	18
FIGURE 16 : RI BEHAVIOUR (SMS AND URC REPORT)	19
FIGURE 17: RI BEHAVIOUR (VOICE CALL)	19
FIGURE 18: 1.8V INTERFACE I2C REFERENCE CIRCUIT.....	20
FIGURE 19: 1.8V INTERFACE I2C REFERENCE CIRCUIT.....	21
FIGURE 20: PCM_SYNC TIMING.....	23
FIGURE 21: EXT CODEC TO MODULE TIMING.....	23
FIGURE 22: MODULE TO EXT CODEC TIMING.....	23
FIGURE 23: AUDIO CODEC REFERENCE CIRCUIT.....	25
FIGURE 24: RECEIVER INTERFACE CONFIGURATION.....	26
FIGURE 25: MICROPHONE INTERFACE CONFIGURATION.....	26
FIGURE 26: RF CONNECTOR.....	30
FIGURE 27: TOP AND BOTTOM VIEW.....	39

1 Introduction

This document describes the electronic specifications, RF specifications, interfaces, mechanical characteristics and testing results of the SIMCom SIM7906E-PCIE modules. With the help of this document and other SIM7906E-PCIE software application notes/user guides, users can understand and use SIM7906E-PCIE modules to design and develop applications quickly.

1.1 Product Outline

The SIM7906E-PCIE modules support 2 type air-interface standards including WCDMA, TDD-LTE and FDD-LTE. Users can choose the module according to the wireless network configuration. The supported radio frequency bands are described in the following table.

Table 1: SIM7906E-PCIE series frequency bands

Standard	Frequency bands
WCDMA	B1/B3/B5/B8
LTE(TDD)	B38/B39/B40/B41
LTE(FDD)	B1/B3/B5/B7/B8/B20/B28/B32
2CA	B1+B1/B5/B8/B20; B3+B3/B5/B7/B8/B20/B28; B7+B5/B7/B8/B20/B28; B20+B32; B38+B38; B39+B39 B40+B40; B41+B41
GNSS	GPS/Galileo/QZSS/GLONASS/BeiDou/Compass

1.2 Hardware Interface Overview

SIM7906E-PCIE provides various hardware interfaces via Mini PCI Express card connector.

Table 2: Hardware Interface function

Interface Type	SIM7906E-PCIE	SIM7906E-PCIEAU	SIM7906E-PCIEU
Power	•	•	•
PERST#	•	•	•
W_DISABLE#	•	•	•
USIM interface	•	•	•
Analog voice interface		•	
PCM/I2S interface	•		•
PCIe GEN2.0 interface	•		
Full function UART interface		•	•
I2C interface	•	•	•
USB2.0 interface	•	•	•
LED_WWAN#	•	•	•
LED_WLAN#	•		
LED_WPAN#	•		
WAKE#			•

NOTE

Only SIM7906E-PCIEAX can support analog audio function. If analog audio is needed and above hardware version cannot satisfy the need of you, please consult our sales staff, for more information.

Table 3: Hardware Interface definitions

SIM7906E-PCIE interface:

Pin#	Name	Pin#	Name
51	PCM_SYNC	52	VCC
49	PCM_DIN	50	GND
47	PCM_DOUT	48	NC
45	PCM_CLK	46	LED_WPAN#
43	GND	44	LED_WLAN#

41	VCC	42	LED_WWAN#
39	VCC	40	GND
37	GND	38	USB_DP
35	GND	36	USB_DN
33	PCle_TX_P	34	GND
31	PCle_TX_M	32	SDA
29	GND	30	SCL
27	GND	28	NC
25	PCle_RX_P	26	GND
23	PCle_RX_M	24	VCC
21	GND	22	PERST_N
19	UART_TXD	20	W_DISABLE#
17	UART_RXD	18	GND

Mechanical Key

15	GND	16	USIM_DET
13	PCle_CLK_P	14	USIM_RST
11	PCle_CLK_M	12	USIM_CLK
9	GND	10	USIM_DATA
7	PCle_CLKREQ_N	8	USIM_VDD
5	NC	6	NC
3	PCle_RESET_N	4	GND
1	PCle_WAKE_N	2	VCC

SIM7906E-PCIEAU interface:

Pin#	Name	Pin#	Name
51	NC	52	VCC
49	NC	50	GND
47	NC	48	NC
45	NC	46	UART_DTR
43	GND	44	UART_RI
41	VCC	42	LED_WWAN#
39	VCC	40	GND
37	GND	38	USB_DP
35	GND	36	USB_DN
33	NC	34	GND
31	NC	32	SDA
29	GND	30	SCL
27	GND	28	NC
25	NC	26	GND
23	NC	24	VCC
21	GND	22	PERST_N
19	UART_TXD	20	W_DISABLE#

17	UART_RXD	18	GND
Mechanical Key			
15	GND	16	USIM_DET
13	UART_RTS	14	USIM_RST
11	UART_CTS	12	USIM_CLK
9	GND	10	USIM_DATA
7	EAR_N	8	USIM_VDD
5	EAR_P	6	NC
3	MIC_N	4	GND
1	MIC_P	2	VCC

SIM7906E-PCIEU interface:

Pin#	Name	Pin#	Name
51	PCM_SYNC	52	VCC
49	PCM_DIN	50	GND
47	PCM_DOUT	48	NC
45	PCM_CLK	46	UART_DTR
43	GND	44	UART_RI
41	VCC	42	LED_WWAN#
39	VCC	40	GND
37	GND	38	USB_DP
35	GND	36	USB_DN
33	NC	34	GND
31	NC	32	SDA
29	GND	30	SCL
27	GND	28	NC
25	NC	26	GND
23	NC	24	VCC
21	GND	22	PERST_N
19	UART_TXD	20	W_DISABLE#
17	UART_RXD	18	GND
Mechanical Key			
15	GND	16	USIM_DET
13	UART_RTS	14	USIM_RST
11	UART_CTS	12	USIM_CLK
9	GND	10	USIM_DATA
7	NC	8	USIM_VDD
5	NC	6	NC
3	NC	4	GND
1	WAKE#	2	VCC

1.3 Hardware Block Diagram

The following figure is SIM7906E-PCIE hardware block diagram.

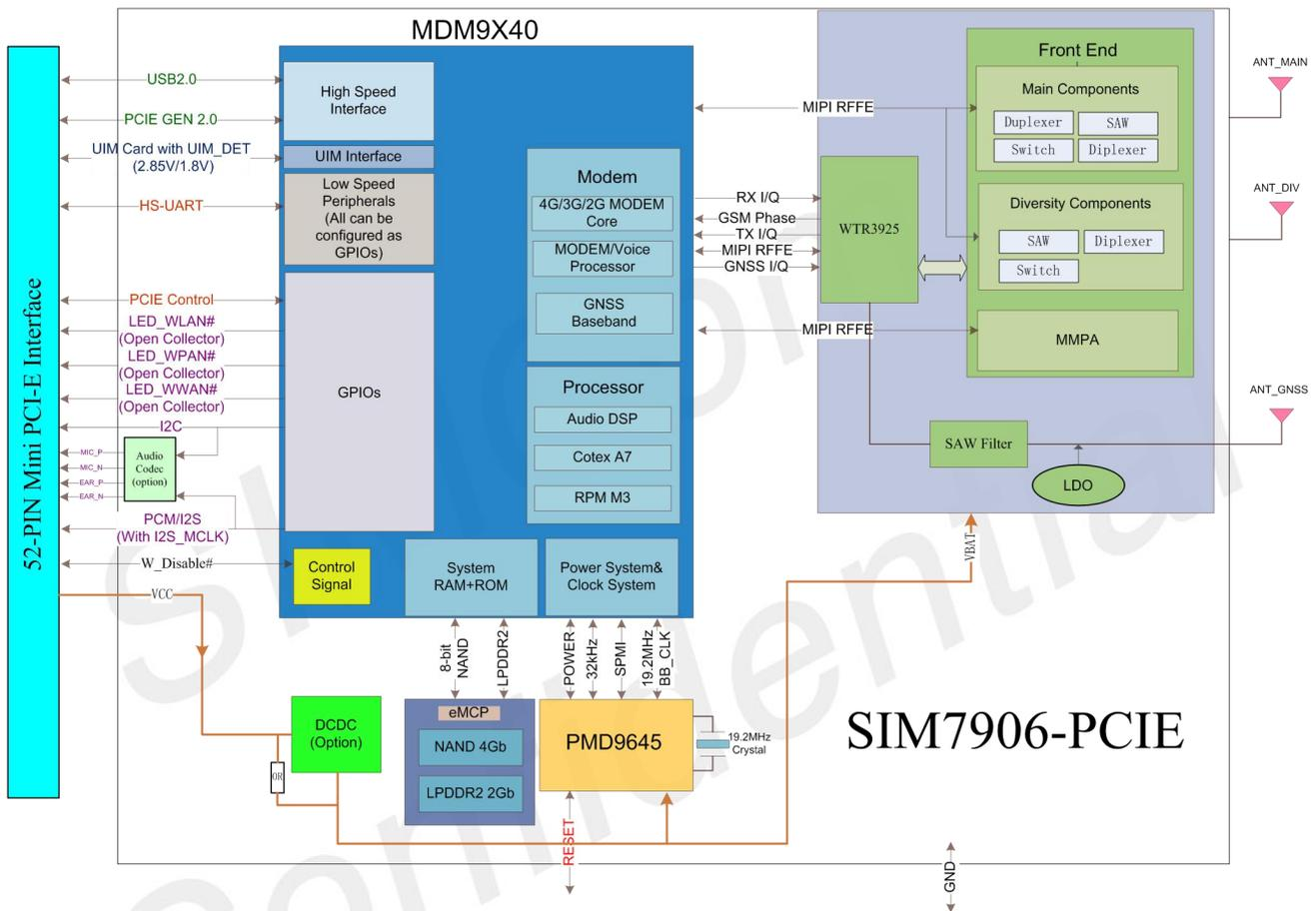

Figure 1: SIM7906E-PCIE Block Diagram

1.4 Functional Overview

Table 4: SIM7906E-PCIE Key Features

Feature	Implementation
Power supply	VCC: Normal Voltage: 3.1V ~4.4V, Recommended 3.3V
Power saving	Current in sleep mode : TBD
Radio frequency bands	Please refer to the table 1

Transmitting power	WCDMA power class: 3 (0.25W) LTE power class: 3 (0.25W)
Data Transmission Throughput	UMTS R99 speed: 384 kbps DL/UL HSPA+: 5.76 Mbps(UL), 42 Mbps(DL) FDD-LTE CAT6:Max 300Mbps (DL), 50Mbps (UL) TDD-LTE CAT6:Max 226Mbps (DL), 28Mbps (UL)
Antenna	UMTS/LTE main antenna. UMTS/LTE auxiliary antenna. GNSS antenna.
GNSS	GNSS engine (GPS, GLONASS and BD) Protocol: NMEA
SMS	MT, MO, CB, Text and PDU mode SMS storage: USIM card or ME (default) Transmission of SMS alternatively over CS or PS.
USIM interface	Support identity card: 1.8V/ 2.85V
USIM application toolkit	Support SAT class 3, GSM 11.14 Release 98 Support USAT
Phonebook management	Support phonebook types: DC, MC, RC, SM, ME, FD, ON, LD, EN
Audio feature	Support PCM interface (PCIE support master and slave mode) Only SIM7906E-PCIEAX support analog voice interface: One MIC analog input interface. Ear Jack Max drive 32Ω load output, max output power 40mW.
UART interface	A full modem serial port by default Baud rate: 300bps to 921600bps(default:115200bps,AT+IPR=115200) Can be used as the AT commands or data stream channel. Support RTS/CTS hardware handshake and software ON/OFF flow control Multiplex ability according to GSM 07.10 Multiplexer Protocol.
PCle interface	SIM7906E-PCIE support PCle Gen 2 (PCle Gen 1 compatible) Up to 5Gbps data rate
USB	USB2.0: high speed interface, support USB operations at low-speed and full-speed, which refer to USB1.0 and USB1.1.
Firmware upgrade	Firmware upgrade over USB interface FOTA
Physical characteristics	Size:50.8*30*4.4mm Weight:10.5g
Temperature range	Normal operation temperature: -30°C to +70°C 3GPP compliant Extended operation temperature: -40°C to +85°C* Storage temperature -45°C to +90°C

NOTE

The performance will be reduced slightly from the 3GPP specifications if the temperature is outside the normal operating temperature range and still within the extreme operating temperature range.

2 Package Information

2.1 Pin Assignment Overview

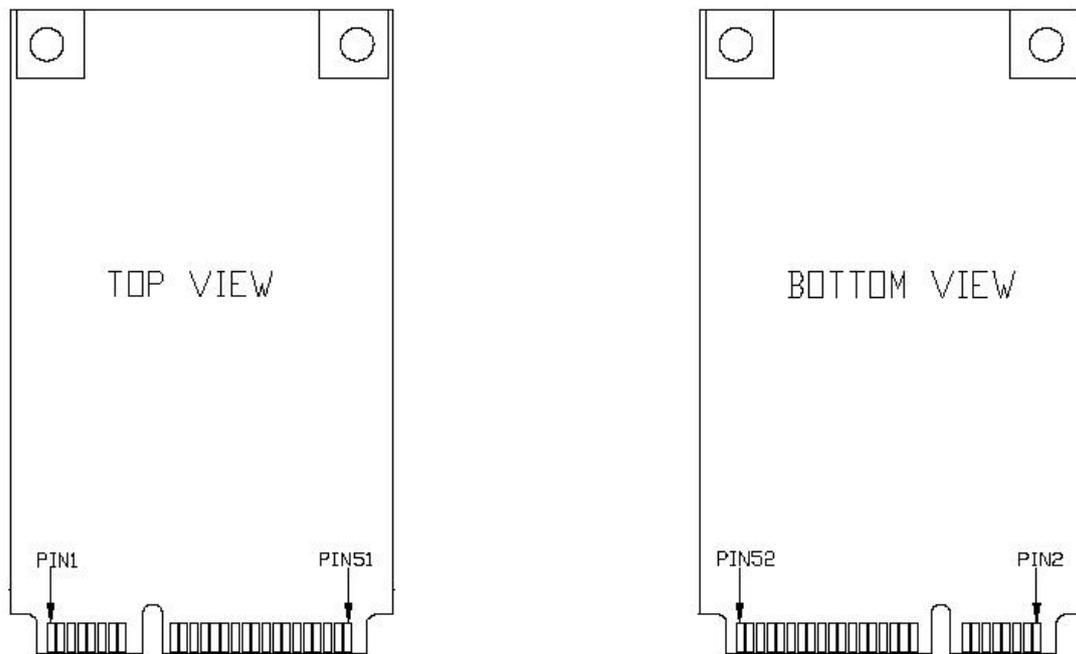

Figure 2: SIM7906E-PCIE Pin Assignment Overview

2.2 PCI Express Mini Card Connector Pin Description

Table 5: PCI Express Mini Card Connector Pin Description

Mini PCIe Interface	SIM7906E Pin Name	Pin number	I/O	Description	Comment
Power interface					
3.3Vaux	VCC	2,24,39,41,52	I	3.3V Power supply for module	Recommended 3.3V
GND	GND	4,9,15,18,21,26,27,29,34,35,37,40,43,50		Ground	-
Reset					
PERST#	PERST_N	22	I	Reset input (Active low)	If unused, keep open.
USB 2.0 Interface					
USB_D+	USB_DP	38	I/O	USB 2.0 high speed port for data transfer, voice call, debug and FW download, etc.	If unused, keep open.
USB_D-	USB_DN	36			
USIM interface					
UIM_POWER	USIM_VDD	8	O	Power output for USIM card, its output Voltage depends on USIM card type automatically. Its output current is up to 50mA.	-
UIM_DATA	USIM_DATA	10	I/O	USIM Card data I/O, which has been pulled up via a 20KR resistor to USIM_VDD internally. Do not pull it up or down externally.	-
UIM_CLOCK	USIM_CLK	12	O	USIM clock	USIM_CLK raise time and fall time should be less 50ns.
UIM_RESET	USIM_RST	14	O	USIM Reset	-
UIM_VPP	USIM_DET	16	I	USIM card detect	Default closed this function
UART interface					
REFCLK-	PCle_CLK_M /UART_CTS	11	I	SIM7906E-PCIE: PCle_CLK_M other version: Clear to Send	If unused, keep open

REFCLK+	PCIe_CLK_P /UART_RTS	13	O	SIM7906E-PCIE: PCIe_CLK_P other version: Request to send	
Reserved	UART_RXD	17	I	all version: Receive Data	
Reserved	UART_TXD	19	O	all version: Transmit Data	
LED_WLAN#	LED_WLAN#/UART_RI	44	O	SIM7906E-PCIE: LED_WLAN# other version: Ring Indicator	
LED_WPAN#	LED_WPAN#/UART_DTR	46	I	SIM7906E-PCIE: LED_WPAN# other version: DTE get ready	
I2C interface					
SMB_CLK	SCL	30	O	I2C clock output (default 1.8V interface, 2.2KΩ Pulled up internal)	If unused, keep open
SMB_DATA	SDA	32	I/O	I2C data input/output (default 1.8V interface, 2.2KΩ Pulled up internal)	
PCIe interface					
PERn0	PCIe_RX_M/NC	23	I	SIM7906E-PCIE: PCIe data receive negative other version: NC	
PERp0	PCIe_RX_P /NC	25	I	SIM7906E-PCIE: PCIe data receive positive other version: NC	If unused, keep open
PETn0	PCIe_TX_M /NC	31	O	SIM7906E-PCIE: PCIe transmit negative other version: NC	
PETp0	PCIe_TX_P /NC	33	O	SIM7906E-PCIE: PCIe transmit positive other version: NC	
PCM interface					
Reserved	PCM_CLK /NC	45	I/O	SIM7906E-PCIE/SIM7906E-PCIEU/ PCM data bit clock. other version: NC	If unused, keep open
Reserved	PCM_DOUT /NC	47	O	SIM7906E-PCIE/ SIM7906E-PCIEU: PCM data output	

Reserve d	PCM_DIN /NC	49	I	other version: NC SIM7906E-PCIED/SIM7906 E-PCIEU: PCM data input	
Reserve d	PCM_SYNC /NC	51	I/O	other version: NC SIM7906E-PCIED/ SIM7906E-PCIEU: PCM data frame sync signal. other version: NC	
Other interface					
WAKE#	PCle_WAKE_N/ MIC_P/ WAKE#/ MIC_N/	1	I/O	SIM7906E-PCIE: PCle_WAKE_N SIM7906E-PCIEAU: MIC input positive SIM7906E-PCIEU:WAKE#	
COEX1	PCle_RESET_N/ MIC_N/ NC	3	I	SIM7906E-PCIE: PCle_RESET_N SIM7906E-PCIEAU: MIC negative input SIM7906E-PCIEU: NC	If unused, keep open
COEX2	EAR_P/ NC	5	O	SIM7906E-PCIEAU: Receiver positive output other version: NC	
CLKREQ #	PCle_CLKREQ_ N/EAR_N/ NC	7	O	SIM7906E: PCle_CLKREQ_N SIM7906E-PCIEAU: Receiver negative output SIM7906E-PCIEU: NC	
W_DISA BLE#	W_DISABLE#	20	I	RF Control Input	If unused, keep open
LED_W WAN#	LED_WWAN#	42	O	Network Status Indication output	If unused,keep open
Other PIN	NC	6 ,28, 48	--	No connection	Keep open

2.3 Package Dimensions

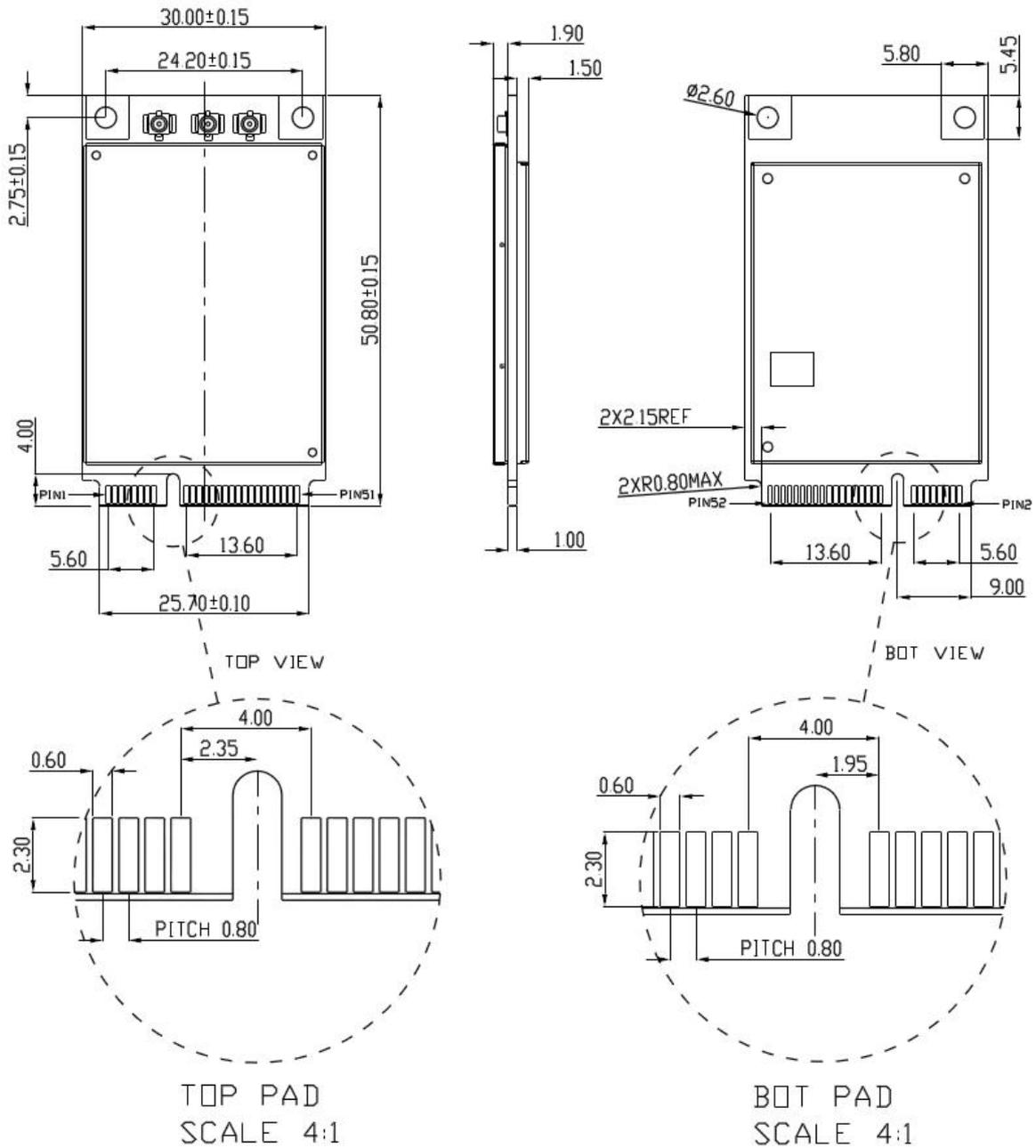

Figure 3: Dimensions of SIM7906E-PCIE (Unit: mm)

3 Interface Application

3.1 Power Supply

The recommended power supply voltage of SIM7906E-PCIE

Table 6: Recommended Power Supply Characteristics

Symbol	Parameter	Min	Type	Max	Unit
VCC	Power supply voltage	3.1	3.3	4.4	V
I _{VCC(peak)}	Supply current capability	-	-	2000	mA

3.2 PERST#

SIM7906E-PCIE can be reset by pulling the PERST# pin down to ground.

The PERST# pin has been pulled up with a 40KΩ resistor to 1.8V internally, so there is no need to pull it up externally. It is strongly recommended to an ESD protection diode close to the RESET pin.

Please refer to the following figure for the recommended reference circuit.

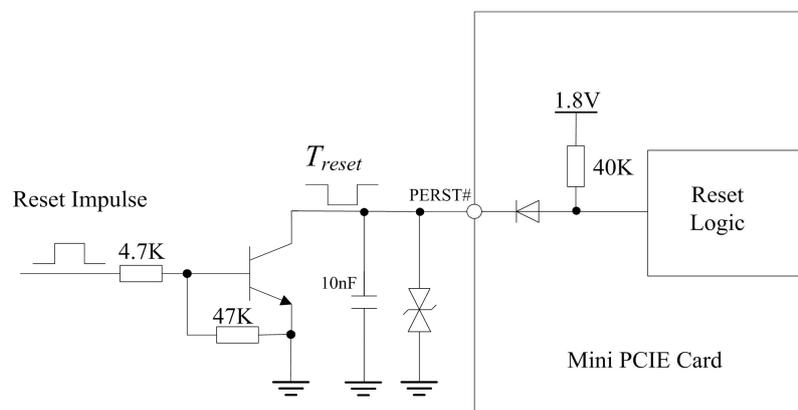

Figure 4: PERST# Reference Circuit

Table 7: PERST# Pin Electronic Characteristic

Symbol	Description	Min.	Typ.	Max.	Unit
T_{reset}	The active low level time impulse on PERST# pin to reset module	100	300	500	ms
V_{IH}	Input high level voltage	1.17	1.8	3.6	V
V_{IL}	Input low level voltage	-0.3	0	0.3	V

3.3 W_DISABLE#

The W_DISABLE# pin can be used to control SIM7906E-PCIE to enter or exit the Flight mode. In Flight mode, the RF circuit is closed to prevent interference with other device and minimize current consumption.

Table 8: W_DISABLE# Pin Status

W_DISABLE# status	Module operation
Input Low Level	Flight Mode: RF is closed.
Input High Level	Normal Mode: Working mode is determined by AT command. AT+CFUN=0: RF is closed AT+CFUN=4: RF is working

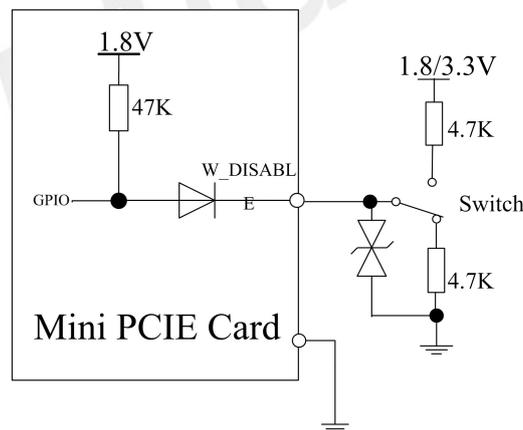

Figure 5: W_DISABLE# Reference Circuit

Table 9: W_DISABLE# Pin Electrical Characteristic

Symbol	Parameter	Min	Type	Max	Unit
V_{IH}	High-level input voltage	1.17	1.8	3.6	V

V_{IL}	Low-level input voltage	-0.3	0	0.3	V
----------	-------------------------	------	---	-----	---

3.4 LED_WWAN#

The LED_WWAN# pin can be used to drive a network status indication LED by default. Its status is listed in the following table.

Table 10: Network Status Indication LED Status

LED Status	Module Status
On	Searching Network/Call Connect
200ms On, 200ms Off	Data Link established/4G Registered network
800ms On, 800ms Off	3G Registered network
Off	Power off / Sleep mode(AT+CSCLK=1,DTR is pulled up)

Reference circuit is recommended in the following figure:

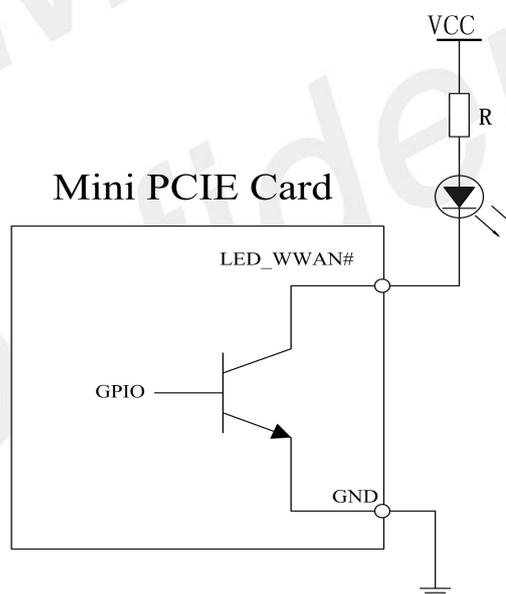

Figure 6: LED_WWAN# Reference Circuit

3.5 WAKE#

WAKE# interface, MIC_P and PCIe_WAKE_N use one hardware interface.

SIM7906E-PCIE: PCIE_WAKE_N

SIM7906E-PCIEU: WAKE#

SIM7906E-PCIEAU: MIC_P

The WAKE# pin can be used as an interrupt signal to host. Normally it will keep high logic level until certain condition such as receiving SMS, voice call (CSD, video) or URC reporting, then WAKE# will change to low logic level to inform the master (client PC). It will stay low until the master clears the interrupt event with AT command.

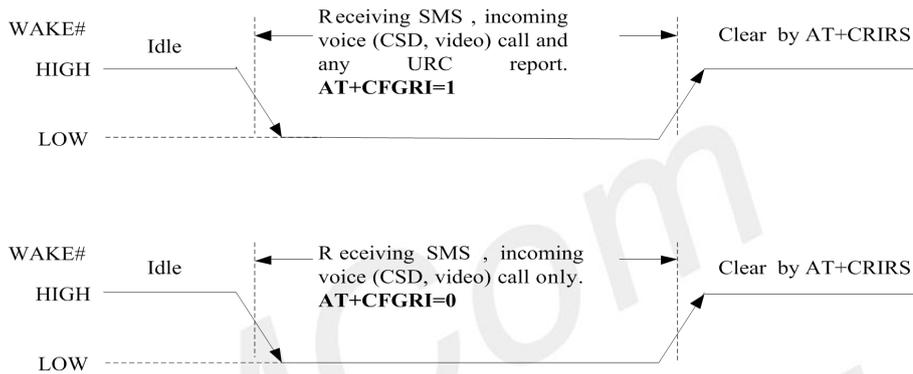

Figure 7: WAKE# behaviour

However, if the module is used as caller, the WAKE# will remain high. Please refer to the following figure.



Figure 8: WAKE# behaviour as a caller

WAKE# Reference circuit is recommended in the following figure:

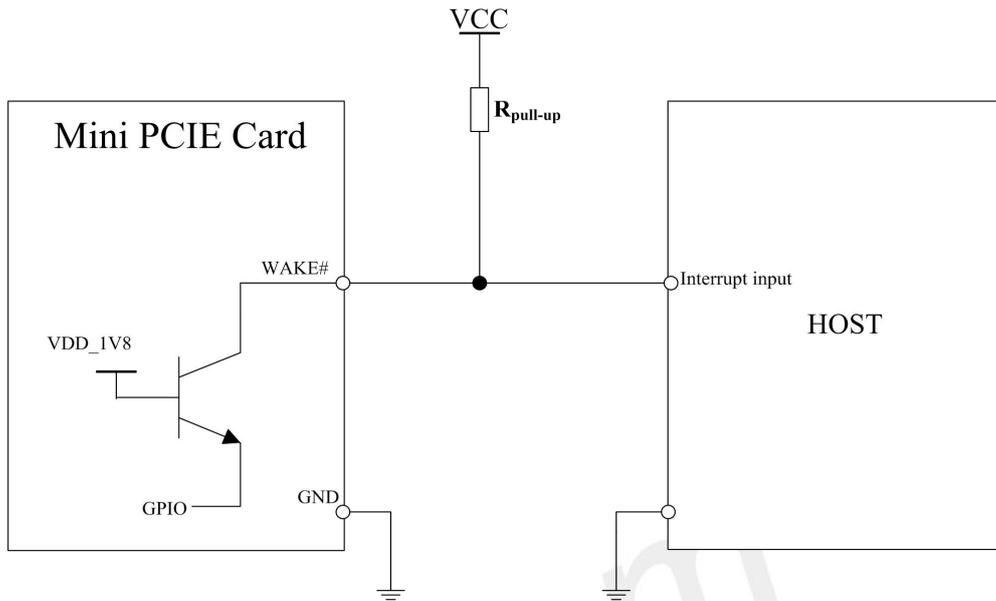

Figure 9: WAKE# Reference Circuit

NOTE

If PCIe or Analog audio is available, wake up function is invalid. Please consult our sales staff for more information.

3.6 USB 2.0

SIM7906E-PCIE is compliant with USB 2.0 specification. It supports full-speed and high-speed when acting as a peripheral device.

3.6.1 USB Application Guide

SIM7906E-PCIE can be used as a USB device. SIM7906E-PCIE supports the USB suspend and resume mechanism which can reduce power consumption. If there is no data transmission on the USB bus, SIM7906E-PCIE will enter suspend mode automatically, and will be resumed by some events such as voice call or receiving SMS, etc.

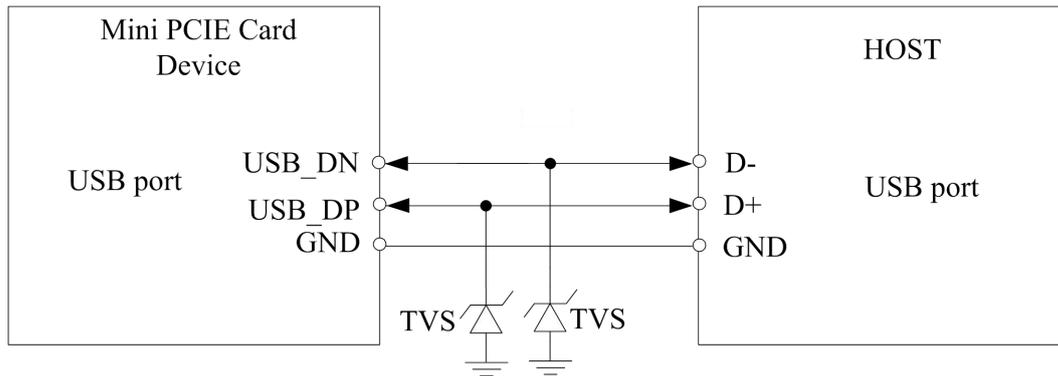

Figure 10: USB Reference Circuit

Because of the high bit rate on USB bus, please pay more attention to the influence of the junction capacitance of the ESD component on USB data lines. Typically, the capacitance should be less than 1pF. It is recommended to use an ESD protection component such as ESD9L5.0ST5G provided by On Semiconductor (www.onsemi.com).

NOTE

1. The USB_DN and USB_DP nets must be traced by 90Ohm \pm 10% differential impedance.
2. The SIM7906E-PCIE has two kinds of interface (UART and USB) to connect to host CPU. For example, on windows XP operating system, USB interface is mapped to 4 virtual ports: "SimTech HS-USB AT Port 9001", "SimTech HS-USB Audio port 9001", "SimTech HS-USB Diagnostics 9001", "SimTech HS-USB NMEA 9001".

3.7 USIM Interface

SIM7906E-PCIE support both Class B and Class C type SIM card . USIM interface is powered from an internal regulator in the module.

Table 11: USIM Electronic characteristic in 1.8V mode (USIM_VDD =1.8V)

Symbol	Parameter	Min.	Typ.	Max.	Unit
USIM_VDD	LDO power output voltage	1.75	1.8	1.95	V
V _{IH}	High-level input voltage	0.65·USIM_VDD	-	USIM_VDD +0.3	V
V _{IL}	Low-level input voltage	-0.3	0	0.35·USIM_VDD	V
V _{OH}	High-level output	USIM_VDD	-	USIM_VDD	V

	voltage		-0.45			
V_{OL}	Low-level voltage	output	0	0	0.45	V

Table 12: USIM Electronic characteristic 2.85V mode (USIM_VDD =2.85V)

Symbol	Parameter	Min.	Typ.	Max.	Unit
USIM_VDD	LDO power output voltage	2.75	2.85	3.05	V
V_{IH}	High-level input voltage	$0.65 \cdot USIM_VDD$	-	$USIM_VDD + 0.3$	V
V_{IL}	Low-level input voltage	-0.3	0	$0.35 \cdot USIM_VDD$	V
V_{OH}	High-level voltage	USIM_VDD -0.45	-	USIM_VDD	V
V_{OL}	Low-level voltage	0	0	0.45	V

3.7.1 USIM Application Guide

It is recommended to use an ESD protection component such as ST (www.st.com) ESDA6V1W5. Note that the SIM peripheral circuit should be close to the SIM card socket. For more details of AT commands about USIM, please refer to document [1].

The SIM_DET pin is used for detection of the SIM card hot plug. User can select the 8-pin SIM card holder to implement SIM card detection function.

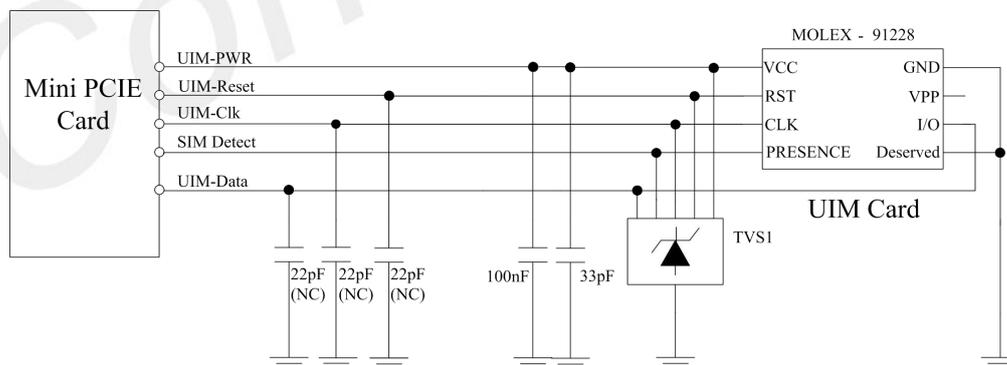

Figure 11: USIM interface reference circuit with detection function

For the normal open kind SIM socket, customer should set AT+UIMHOTSWAPLEVEL=0, and for the normal close kind SIM socket, customer should set AT+UIMHOTSWAPLEVEL=1.

If the SIM card detection function is not used, user can keep the SIM_DET pin open. The reference circuit of 6-pin SIM card holder is illustrated in the following figure.

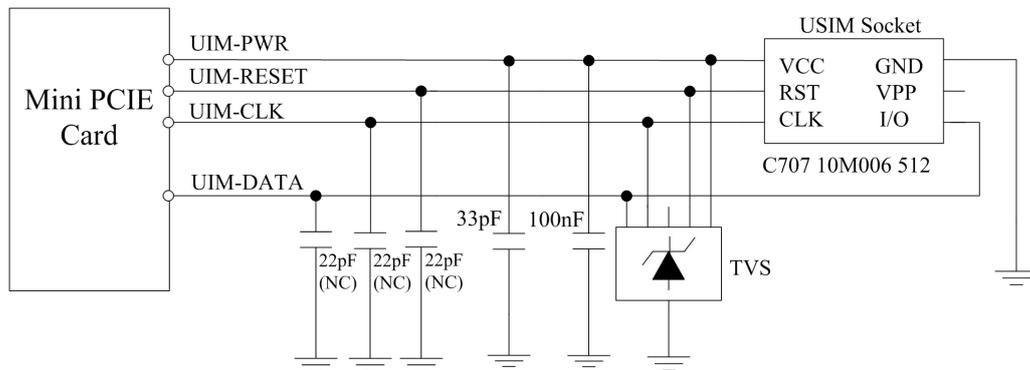

Figure 12: USIM interface reference circuit

NOTE

1. USIM_DATA has been pulled up with a 10KΩ resistor to USIM_VDD in module.
2. The rise time and fall time of USIM_CLK should be less 50ns.

3.8 UART Interface

SIM7906E-PCIEAU/ SIM7906E-PCIEU provides one UART (universal asynchronous serial transmission) port.

Only SIM7906E-PCIE Provide 2-wire UART interfaces.

The module is as the DCE (Data Communication Equipment) and the client PC is as the DTE (Data Terminal Equipment). AT commands are entered and serial communication is performed through UART interface.

3.8.1 UART Application Guide

The application circuit is in the following figures.

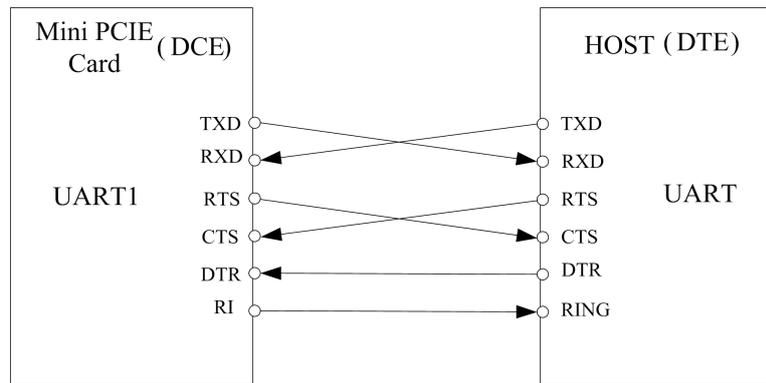

Figure 13: UART Full mode

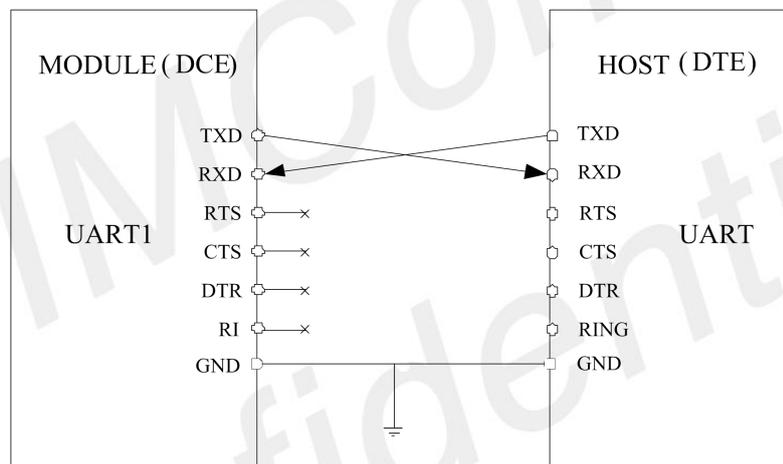

Figure 14: UART Null mode

Table 13: UART Electrical Characteristic

Symbol	Parameter	Min	Typ	Max	Unit
V _{IH}	High-level input voltage	1.17	1.8	2.1	V
V _{IL}	Low-level input voltage	-0.3	0	0.63	V
V _{OH}	High-level output voltage	1.35	1.8	1.8	V
V _{OL}	Low-level output voltage	0	0	0.45	V

The SIM7906E-PCIE UART is 1.8V interface. A level shifter should be used if user's application is equipped with a 3.3V UART interface. The level shifter TXB0108RGYR provided by Texas Instruments is recommended. The reference design of the TXB0108RGYR is in the following figures.

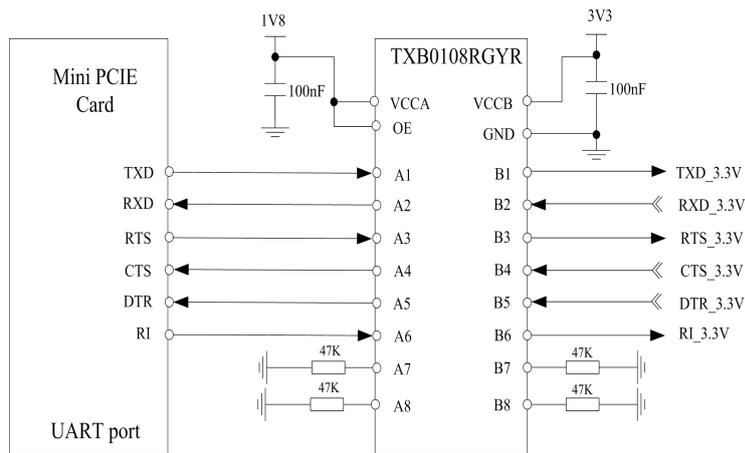

Figure 15: Reference circuit of level shift

To comply with RS-232-C protocol, the RS-232-C level shifter chip should be used to connect SIM7906E-PCIE to the RS-232-C interface. In this connection, the TTL level and RS-232-C level are converted mutually. SIMCom recommends that user uses the SP3238ECA chip with a full modem. For more information please refers to the RS-232-C chip datasheet.

NOTE

SIM7906E-PCIE supports the following baud rate: 300, 600, 1200, 2400, 4800, 9600, 19200, 38400, 57600, 115200, 230400, 460800, 921600, 3200000, 3686400, 4000000bps. Default baud rate is 115200bps.

3.8.2 RI Behavior

The RI pin can be used as an interrupt output signal to inform the host controller such as application CPU.

Normally RI will keep high level until certain conditions such as receiving SMS, or a URC report coming, and then it will change to low level. It will stay low until the host controller clears the interrupt event with “AT+CRIRS” AT command.

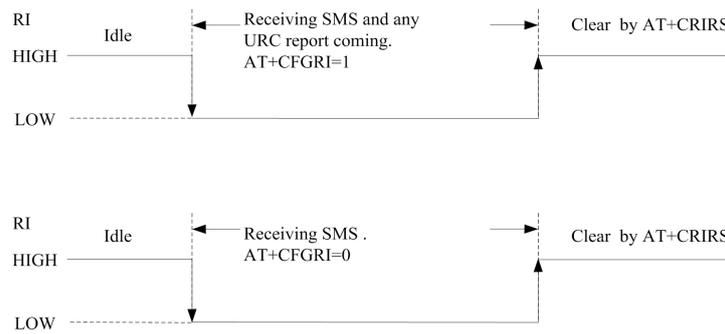

Figure 16 : RI behaviour (SMS and URC report)

Normally RI will be kept high level until a voice call, then it will output periodic rectangular wave with 5900ms low level and 100ms high level. It will output this kind of periodic rectangular wave until the call is answered or hung up.

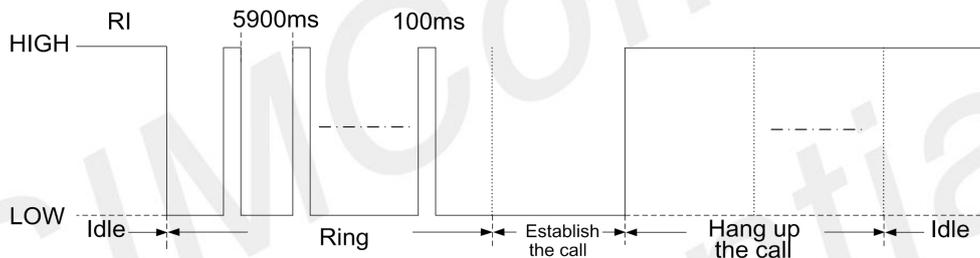

Figure 17: RI behaviour (voice call)

NOTE

For more details of AT commands about UART, please refer to document [1] and [22].

DTR pin can be used to wake SIM7906E-PCIE from sleep. When SIM7906E-PCIE enters sleep mode, pulling down DTR can wake SIM7906E-PCIE.

3.9 I2C Interface

SIM7906E-PCIE provides I2C interface compatible with I2C specification, version 2.1, with clock rate up to 400 kbps. Its operation voltage is 1.8V.

NOTE

Since the I2C is connected to the audio codec chip on board, the users should choose the I2C device whose address is not the same with the audio codec. If the audio codec chip is not mounted on board, users could ignore this.

3.9.1 I2C Application Guide

The following figure shows the I2C bus reference design.

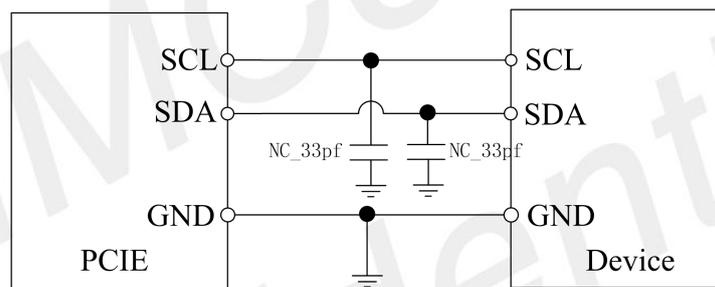

Figure 18: 1.8V interface I2C reference circuit

NOTE

SIM7906E-PCIE is pulled up to 1.8V via 2.2K resistors in module default. Therefore, the application circuit does not need external resistance.

If you need 3.3V interface, Please connect our sales for more information.

For more details about I2C AT commands please refer to document [1].

Table 14: I2C Electrical Characteristic

Symbol	Parameter	Min	Typ	Max	Unit
V _{IH}	High-level input voltage	1.17	1.8	2.1	V
V _{IL}	Low-level input voltage	-0.3	0	0.63	V
V _{OH}	High-level output voltage	1.35	1.8	1.8	V
V _{OL}	Low-level output voltage	0	0	0.45	V

3.10 PCIe interface

SIM7906E-PCIE support one PCIe Gen2.0 (PCIe Gen 1.0 compliance) interface, PCIe function cannot use with full function UART.

PCIe reference circuit:

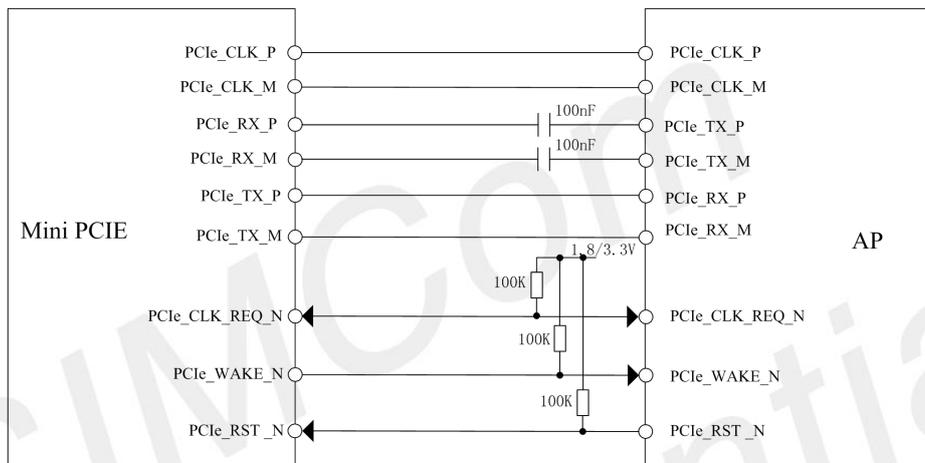

Figure 19: 1.8V interface I2C reference circuit

NOTE

- 1、 Only SIM7906E-PCIED support PCIe interface. If user needs this function, please consult our sales staff for more information.
- 2、 PCIe function is under development. If user needs this function, please consult our sales staff for more information.

3.11 PCM and Analog Audio Interface

3.11.1 PCM Interface

SIM7906E-PCIEX provides hardware PCM interface for external codec. (Default PCM interface)

SIM7906E-PCIEX PCM interface can be used in short sync master/slave mode, and only supports 16 bits linear format.

NOTE

1. The PCM interface cannot be used if audio codec chip is mounted on PCIE board.
2. PCM voice mode is under development. For more details please consult our FEA team.

Table 15: PCM Specification

Characteristics	Specification
Line Interface Format	Linear(Fixed)
Data length	16bits(Fixed)
PCM Clock/Sync Source	Master Mode(default)
PCM Clock Rate	2048/4096 KHz (Fixed)
PCM Sync Format	Short sync(Fixed)
Data Ordering	MSB

NOTE

Note: PCM interface can be control by AT command. For more details please refer to document [1]

Table 16: PCM DC Characteristics

Symbol	Parameter	Min	Type	Max	Unit
V _{IH}	High-level input voltage	1.17	1.8	2.1	V
V _{IL}	Low-level input voltage	-0.3	0	0.63	V
V _{OH}	High-level output voltage	1.35	1.8	1.8	V
V _{OL}	Low-level output voltage	0	0	0.45	V

3.11.2 PCM timing

SIM7906E-PCIEX supports 2.048 MHz PCM data in 2G/3G network and 4.096MHz PCM data in 4G network, sync timing for 16 bits linear format codec.

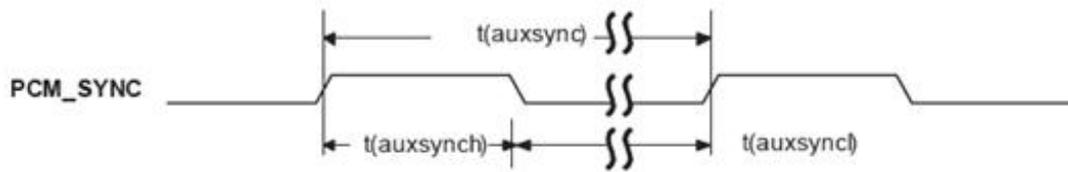

Figure 20: PCM_SYNC timing

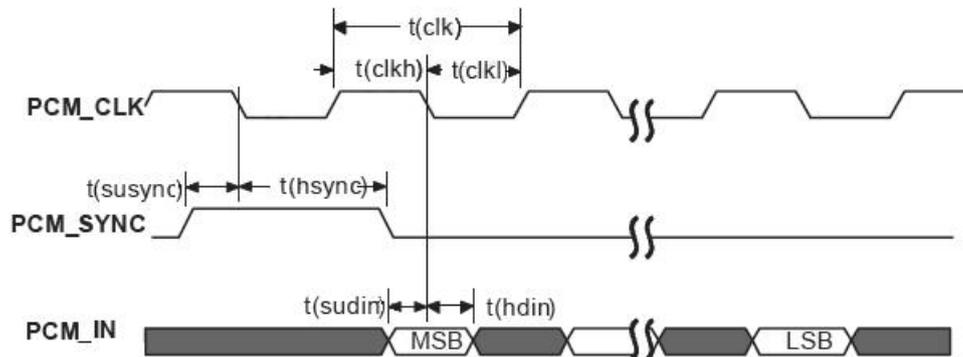

Figure 21: EXT CODEC to MODULE timing

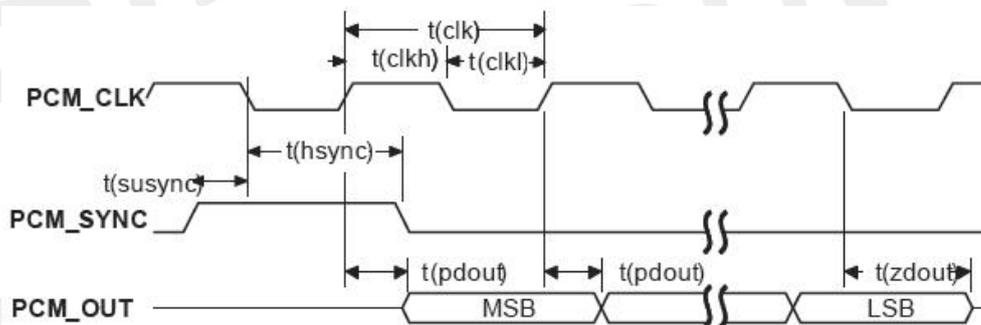

Figure 22: MODULE to EXT CODEC timing

Table 17: PCM Timing parameters (2G/3G mode)

Parameter	Description	Min	Typ	Max	Unit
T(sync)	PCM_SYNC cycle time	–	125	–	μs
T(synch)	PCM_SYNC high level time	–	488	–	ns
T(syncnl)	PCM_SYNC low level time	–	124.5	–	μs
T(clk)	PCM_CLK cycle time	–	488	–	ns
T(clkh)	PCM_CLK high level time	–	244	–	ns
T(clkl)	PCM_CLK low level time	–	244	–	ns
T(susync)	PCM_SYNC setup time high before falling	–	122	–	ns

	edge of PCM_CLK				
T(hsync)	PCM_SYNC hold time after falling edge of PCM_CLK	–	366	–	ns
T(sudin)	PCM_IN setup time before falling edge of PCM_CLK	60	–	–	ns
T(hdin)	PCM_IN hold time after falling edge of PCM_CLK	60	–	–	ns
T(pdout)	Delay from PCM_CLK rising to PCM_OUT valid	–	–	60	ns
T(zdout)	Delay from PCM_CLK falling to PCM_OUT HIGH-Z	–	–	60	ns

Table 18: PCM Timing parameters (4G mode)

Parameter	Description	Min	Typ	Max	Unit
T(sync)	PCM_SYNC cycle time	–	62.5	–	μs
T(synch)	PCM_SYNC high level time	–	244	–	ns
T(synccl)	PCM_SYNC low level time	–	62.256	–	μs
T(clk)	PCM_CLK cycle time	–	244	–	ns
T(clkh)	PCM_CLK high level time	–	122	–	ns
T(clkl)	PCM_CLK low level time	–	122	–	ns
T(susync)	PCM_SYNC setup time high before falling edge of PCM_CLK	–	122	–	ns
T(hsync)	PCM_SYNC hold time after falling edge of PCM_CLK	–	122	–	ns
T(sudin)	PCM_IN setup time before falling edge of PCM_CLK	60	–	–	ns
T(hdin)	PCM_IN hold time after falling edge of PCM_CLK	60	–	–	ns
T(pdout)	Delay from PCM_CLK rising to PCM_OUT valid	–	–	122	ns
T(zdout)	Delay from PCM_CLK falling to PCM_OUT HIGH-Z	–	–	122	ns

3.11.3 PCM Application Guide

The following figure shows the reference design of Audio codec chip NAU8810 with SIM7906E-PCIEAX.

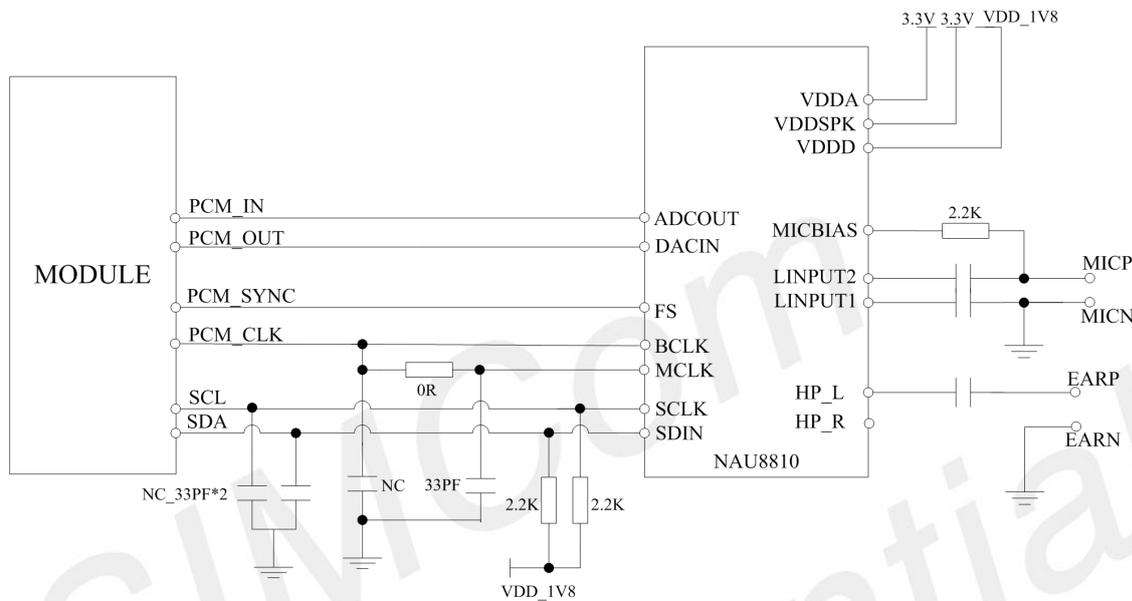

Figure 23: Audio Codec Reference Circuit

3.11.4 Analog Audio Interface

When audio codec chip is mounted on the PCIE board, SIM7906E-PCIEAX provides one analog signal output and one analog input. MICP/N is used as microphone input; EARP/N is used as audio output. Regarding audio parameters configuration, please refer to the ATC manual.

Table 19: MIC input characteristics

Parameter	Min	Typ	Max	Unit
Mic biasing voltage		2.97		V
Working Current			3	mA
External Microphone Load Resistance	1.2	2.2		K Ω

Table 20: Audio output characteristics

Parameter	Min	Typ	Max	Unit
-----------	-----	-----	-----	------

Load resistance	-	32	-	Ω
Output power	-	40	-	mW

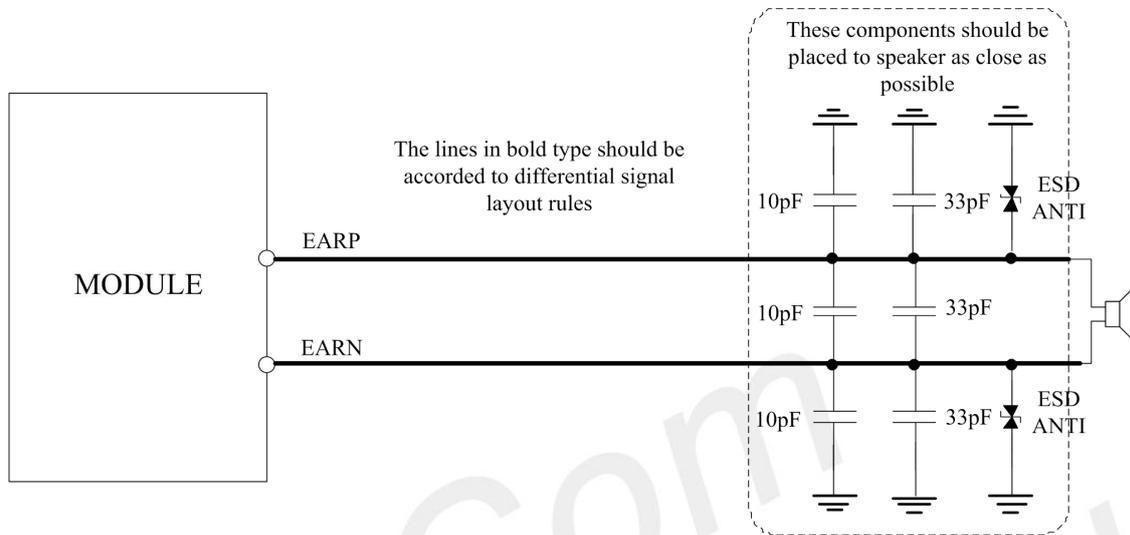

Figure 24: Receiver interface configuration

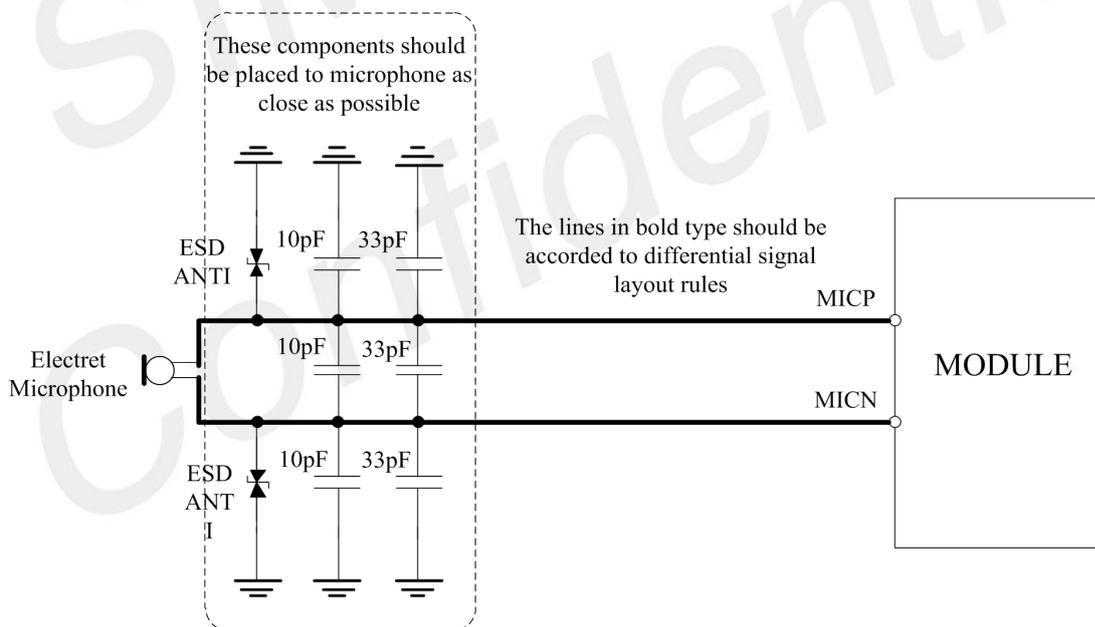

Figure 25: Microphone interface configuration

NOTE

Note: SIM7906E-PCIEAX has integrated MIC bias circuit. There is no need to pull the MICP and MICN up to the external power, just connect it to microphone. MICP and MICN must be differential router lines.

Main audio parameters can be changed to satisfy users' requirement. User can adjust them through AT command according to their own electronic and mechanical design. For more details please refers to audio application document.

SIMCom
Confidential

4 Antenna Interface

SIM7906E-PCIE provides a main antenna interface, a diversity antenna interface and a GNSS antenna interface. The antenna ports have an RF impedance of 50Ω.

4.1 WCDMA/LTE Operating Frequency

The following table shows WCDMA/LTE Operating frequencies

Table 21: SIM7906E-PCIE WCDMA/LTE Operating frequencies

Band	Uplink (UL)	Downlink (DL)	Duplex Mode
WCDMA B1	1920 ~1980 MHz	2110 ~2170 MHz	FDD
WCDMA B3	1710 ~1785 MHz	1805 ~1880 MHz	FDD
WCDMA B5	824 ~849 MHz	869 ~894MHz	FDD
WCDMA B8	880 ~915 MHz	925 ~960 MHz	FDD
LTE B1	1920 ~1980 MHz	2110 ~2170 MHz	FDD
LTE B3	1710 ~1785 MHz	1805 ~1880 MHz	FDD
LTE B5	824 ~849 MHz	869 ~894MHz	FDD
LTE B7	2500~2570MHz	2620~2690MHz	FDD
LTE B8	880 ~915 MHz	925 ~960 MHz	FDD
LTE B20	832~862MHz	791~ 821MHz	FDD
LTE B28	703~748MHz	758~803MHz	FDD
LTE B32	N/A	1452~1492MHz	FDD
LTE B38	2570 ~2620 MHz	2570 ~2620 MHz	TDD
LTE B39	1880 ~1920 MHz	1880 ~1920 MHz	TDD
LTE B40	2300 ~2400 MHz	2300 ~2400 MHz	TDD
LTE B41	2555 ~2655 MHz	2555 ~2655 MHz	TDD

NOTE

LTE-FDD B32 supports Rx only and is only for secondary component carrier.

4.2 GNSS Operating Frequency

The following table shows GNSS Operating frequencies

Table 22: GNSS Operating frequencies

Type	Frequency
GPS/Galileo/QZSS	1575.42±1.023MHz
GLONASS	1597.5~1605.8MHz
BeiDou/Compass	1561.098±2.046MHz

4.3 Antenna Installation

4.3.1 Antenna Requirements

The following table shows the requirements on main antenna, Diversity antenna and GNSS antenna.

Table 23: Recommended WCDMA/LTE antenna Characteristics

Item	Requirements
Direction	Omni directional
Gain	> -3dBi (Avg)
Input impedance	50 Ω
Efficiency	> 30 %
VSWR	< 2
Cable insertion Loss <1GHz	<1dB
Cable insertion Loss 1GHz~2.2GHz	<1.5dB
Cable insertion Loss 2.3GHz~2.7GHz	<2dB

Table 24: Recommended GNSS antenna Characteristics

Item	Requirements
Frequency Range	1559~1609MHZ
Direction	RHCP or liner, RHCP is the first choice
VSWR	< 2
Passive antenna gain	> 0 dBi

Active antenna NF	< 1.5
Active antenna gain	> 0 dBi
Active antenna Embedded LNA gain	< 17 dB

NOTE

It is recommended to use a passive GNSS antenna when LTE B13 or B14 is supported, as the use of active antenna may generate harmonics which will affect the GNSS performance.

4.3.2 Recommended RF Connector for Antenna Installation

When choosing antennas, user should pay attentions to the connector on antenna which should match with the connector on the module.

The RF connector in the module side is an ultra small surface mount coaxial connector (Part Number: U.FL-R-SMT, vended by HRS). It has high performance with wide frequency range, surface mountable and reflows solderable. Following are parameters (Figure 26). Certainly user can visit <http://www.hirose-connectors.com/> for more information.

Shows the RF connector dimension in the following figure:

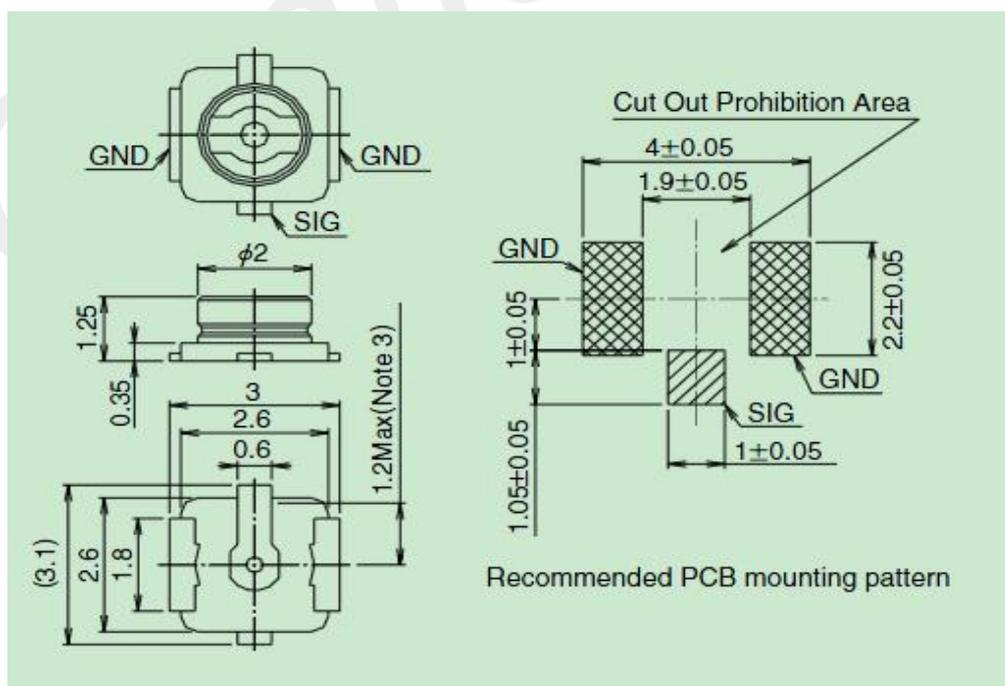

Figure 26: RF connector

The major specifications of the RF connector as below:

Table 25: the major specifications of the RF connector

Item				Specification
Nominal Frequency Range				DC to 6 GHz
Nominal Impedance				50Ω
Temperature Rating				-40°C to + 90°C
Initial Contact Resistance (without conductor resistance)				Center contact 20.0mΩmax. Outer contact 10.0mΩmax.
Voltage	Standing	Wave	Ratio	Meet the requirements of
(V.S.W.R.)				1.3max. (DC~3GHz) 1.4max. (3GHz~6GHz)

To get good RF performance in user's design, SIMCom suggests user to use the matching RF adapter cable which is also supplied by HRS (Part Number: U.FL-LP (V) -040).

SIMCom Confidential

5 Electrical Specification

5.1 Absolute Maximum Ratings

The absolute maximum ratings are described by the following table. Module may be damaged beyond these ratings.

Table 26: Absolute maximum ratings

Parameter	Min	Type	Max	Unit
VCC	-0.3	-	4.7	V
Voltage at digital pins (GPIO,I2C,UART, I2S)	-0.3		2.1	V
Voltage at digital pins (UIM)	-0.3		3.05	V
Voltage at RESET#	-0.3		2.1	V

5.2 Recommended Operating Conditions

Please refer to the follow table for recommended operating conditions.

Table 27: Operating Conditions

Symbol	Parameter	Min	Type	Max	Unit
VCC	Power supply voltage	3.1	3.3	4.4	V
V _{IO}	Voltage at digital pins (1.8V digital I/O)	0	1.8	1.95	V

The operating temperature of Module is listed in the following table.

Table 28: Operating temperature

Parameter	Min.	Typ.	Max.	Unit
Normal operation temperature(3GPP compliant)	-30	25	70	°C
Extended operation temperature*	-40	25	85	°C

Storage temperature -40 25 90 °C

NOTE

Module is able to make and receive voice calls, data calls, SMS and make UMTX/LTE traffic in -40°C ~ +85°C. The performance will be reduced slightly from the 3GPP specifications if the temperature is outside the normal operating temperature range and still within the extreme operating temperature range.

5.3 Operating Mode

5.3.1 Operating Mode

The table below summarizes the various operating modes of SIM7906E-PCIE.

Table 29: Operating Mode

Mode		Function
Normal operation	UMTS/LTE Sleep	AT command "AT+CSCLK=1" can be used to set the module to a sleep mode. In this case, the current consumption of module will be reduced to a very low level and the module can still receive paging message and SMS.
	UMTS/LTE Idle	Software is active. Module is registered to the network, and the Module is ready to communicate.
	UMTS/LTE Talk	Connection between two subscribers is in progress. In this case, the power consumption depends on network settings such as DTX off/on, FR/EFR/HR, hopping sequences, and antenna.
	UMTS/LTE Standby	Module is ready for data transmission, but no data is currently sent or received. In this case, power consumption depends on network settings.
	UMTS/LTE Data transmission	There is data transmission in progress. In this case, power consumption is related to network settings (e.g. power control level); uplink/downlink data rates, etc.
Minimum functionality mode		AT command "AT+CFUN=0" can be used to set the Module to a minimum functionality mode without removing the power supply. In this mode, the RF part of the Module will not work and the USIM card will not be accessible, but the serial port and USB port are still accessible. The power consumption in this mode is lower than

	normal mode.
Flight mode	AT command “AT+CFUN=4” or pulling down the W_disable1# pin can be used to set the Module to flight mode without removing the power supply. In this mode, the RF part of the Module will not work, but the serial port and USB port are still accessible. The power consumption in this mode is lower than normal mode.
Power off	The Module is no power off in this PCIE design. The only way to power off is cut the PCIE' power.

5.3.2 Sleep mode

In sleep mode, the current consumption of module will be reduced to the minimal level, and module can still receive paging message and SMS.

Several hardware and software conditions must be satisfied together in order to let SIM7906E-PCIE enter into sleep mode:

1. UART condition

AT command AT+CSCLK can be used to sleep/wakeup mode. (refer to Document [22] for more details.)

AT+CSCLK=0 can set PCIE always work.

AT+CSCLK=1 can set PCIE sleep when DTR pull high and other task is off.

2. USB condition

PCIE sleep method: User AP send AT+CSCLK=1 via USB, and the AP goes to sleep, and then PCIE enter sleep mode.

PCIE Wake method: AP pulled the DTR to high and send AT+CSCLK=0 via USB, then PCIE enter wake mode.

3. Software condition

NOTE

Before designing, pay attention to how to realize sleeping/waking function.

5.3.3 Minimum functionality mode

Minimum functionality mode ceases a majority function of module, thus minimizing the power consumption. This mode is set by the AT command which provides a choice of the functionality levels.

- AT+CFUN=0: Minimum functionality
- AT+CFUN=1: Full functionality (Default)
- AT+CFUN=4: Disable RF function of the module (Flight mode)

If Module has been set to minimum functionality mode, the RF function and UIM card function will be closed. In this case, the serial port and USB are still accessible, but RF function and UIM card will be unavailable.

If Module has been set to flight mode, the RF function will be closed. In this case, the serial port and USB are still accessible, but RF function will be unavailable.

When Module is in minimum functionality or flight mode, it can return to full functionality by the AT command "AT+CFUN=1".

5.4 Current Consumption

The current consumption is listed in the table below.

Table 30: Current Consumption (VCC =3.3V)

GNSS	
GNSS supply current (AT+CFUN=0,with USB connection)	@ -140dBm, Tracking Typical: TBD
UMTS sleep/idle mode	
WCDMA supply current (GNSS off, without USB connection)	Sleep mode @DRX=9 Typical: TBD Idle mode @DRX=9 Typical: TBD
LTE sleep/idle mode	
LTE FDD supply current (GNSS off, without USB connection)	Sleep mode Typical: TBD Idle mode Typical: TBD
LTE TDD supply current (GNSS off, without USB connection)	Sleep mode Typical: TBD Idle mode Typical: TBD
UMTS Talk	
WCDMA B1	@Power 21.5dBm Typical: TBD
WCDMA B3	@Power 21.5dBm Typical: TBD
WCDMA B5	@Power 21.5dBm Typical: TBD
WCDMA B8	@Power 21.5dBm Typical: TBD
HSDPA data	
WCDMA B1	@Power 23dBm Typical: TBD
WCDMA B3	@Power 23dBm Typical: TBD
WCDMA B5	@Power 23dBm Typical: TBD

WCDMA B8	@Power 23dBm Typical: TBD		
LTE data			
LTE-FDD B1	@5MHz	22.1dBm	Typical: TBD
	@10MHz	23.0dBm	Typical: TBD
	@20MHz	23.0dBm	Typical: TBD
LTE-FDD B3	@1.4MHz	22.0dBm	Typical: TBD
	@5MHz	22.5dBm	Typical: TBD
	@10MHz	22.5dBm	Typical: TBD
LTE-FDD B5	@20MHz	23.0dBm	Typical: TBD
	@1.4MHz	22.2dBm	Typical: TBD
	@5MHz	23.3dBm	Typical: TBD
LTE-FDD B7	@10MHz	22.3dBm	Typical: TBD
	@5MHz	22.0dBm	Typical: TBD
	@10MHz	23.1dBm	Typical: TBD
LTE-FDD B8	@20MHz	23.0dBm	Typical: TBD
	@1.4MHz	21.8dBm	Typical: TBD
	@5MHz	23.1dBm	Typical: TBD
LTE-FDD B20	@10MHz	22.1dBm	Typical: TBD
	@5MHz	22.1dBm	Typical: TBD
	@10MHz	21.8dBm	Typical: TBD
LTE-FDD B28	@20MHz	22.3dBm	Typical: TBD
	@3MHz	22.4dBm	Typical: TBD
	@5MHz	21.8dBm	Typical: TBD
LTE-FDD B28	@10MHz	21.8dBm	Typical: TBD
	@20MHz	22.4dBm	Typical: TBD
	@5MHz	21.9dBm	Typical: TBD
LTE-TDD B38	@10MHz	23.3dBm	Typical: TBD
	@20MHz	22.0dBm	Typical: TBD
	@5MHz	21.7dBm	Typical: TBD
LTE-TDD B40	@10MHz	23.0dBm	Typical: TBD
	@20MHz	22.1dBm	Typical: TBD
	@5MHz	21.6dBm	Typical: TBD
LTE-TDD B41	@10MHz	23.1dBm	Typical: TBD
	@20MHz	22.2dBm	Typical: TBD
	@5MHz	21.6dBm	Typical: TBD

NOTE

In the table above the current consumption value is the typical one of the module tested in the laboratory. In the mass production stage, there may be some difference.

5.5 RF Output Power

The following table shows the RF output power of SIM7906E-PCIE module.

Table 31: Conducted Output Power

Frequency	Max	Min
-----------	-----	-----

WCDMA Bands	24dBm + 1/-3dB	< -50dBm
LTE-FDD Bands	23dBm + 2/-2dB	< -40dBm
LTE-TDD Bands	23dBm + 2/-2dB	< -40dBm

5.6 Conducted Receive Sensitivity

The following tables show conducted RF receiving sensitivity of SIM7906E-PCIE module.

Table 32: SIM7906E-PCIE Conducted RF Receiving Sensitivity

Frequency	Primary (Typ.)	Diversity (Typ.)	SIMO1(Typ.)	SIMO2(Worst Case)
WCDMA B1	-110.0dBm	-111.0dBm	-111.8dBm	-106.7dBm
WCDMA B3	-108.0dBm	-111.0dBm	-112.0dBm	-103.7dBm
WCDMA B5	-111.0dBm	-111.0dBm	-113.dBm	-104.7dBm
WCDMA B8	-110.0dBm	-111.0dBm	-111.6dBm	-103.7dBm
LTE-FDD B1(10M)	-98.3dBm	-98.7dBm	-101.1Bm	-96.3dBm
LTE-FDD B3(10M)	-97.3dBm	-98.2dBm	-100.8dBm	-93.3dBm
LTE-FDD B5(10M)	-99.2dBm	-100.9dBm	-102.9dBm	-94.3dBm
LTE-FDD B7(10M)	-97.1dBm	-98.0dBm	-100.3dBm	-94.3dBm
LTE-FDD B8(10M)	-99.1dBm	-99.4dBm	-101.2dBm	-93.3dBm
LTE-FDD B20(10M)	-98.7dBm	-100.9dBm	-103.0dBm	-93.3dBm
LTE-FDD B28(10M)	-98.4dBm	-100.2dBm	-101.9dBm	-94.8dBm
LTE-FDD B38(10M)	-98.9dBm	-98.7dBm	-101.9dBm	-96.3dBm
LTE-FDD B39(10M)	-98.2dBm	-97.5dBm	-101.5dBm	-96.3dBm
LTE-FDD B40(10M)	-98.2dBm	-98.1dBm	-101.5dBm	-96.3dBm
LTE-FDD B41(10M)	-98.6dBm	-98.0dBm	-101.4dBm	-94.3dBm

NOTE

The data in above table are gotten at static condition.

- 1)SIMO is a smart antenna technology that uses a single antenna at the transmitter side and multiple (two for SIM7906E-PCIE) antennas at the receiver side, which can improve Rx performance.
- 2)Per 3GPP specification.

5.7 ESD

Module is sensitive to ESD in the process of storage, transporting, and assembling. When Module is mounted on the users' mother board, the ESD components should be placed beside the connectors which human body may touch, such as USIM card holder, SD card holder, audio jacks, switches, USB interface, etc. The following table shows the Module ESD measurement performance without any external ESD component.

Table 33: The ESD performance measurement table (Temperature: 25°C, Humidity: 45%)

Part	Contact discharge	Air discharge
VBAT,GND	TBD	TBD
Antenna port	TBD	TBD
USB	TBD	TBD
RESET_N	TBD	TBD
UIM Card	TBD	TBD
Other PADs	TBD	TBD

6 Top and Bottom View of Module



Figure 27: Top and Bottom View

NOTE

The above is the design effect diagram of the module for reference. The actual appearance is subject to the actual product.

7 Appendix

7.1 Coding Schemes and Maximum Net Data Rates over Air Interface

Table 34: Coding Schemes and Maximum Net Data Rates over Air Interface

HSDPA device category	Max data rate (peak)	Modulation type
Category 1	1.2Mbps	16QAM,QPSK
Category 2	1.2Mbps	16QAM,QPSK
Category 3	1.8Mbps	16QAM,QPSK
Category 4	1.8Mbps	16QAM,QPSK
Category 5	3.6Mbps	16QAM,QPSK
Category 6	3.6Mbps	16QAM,QPSK
Category 7	7.2Mbps	16QAM,QPSK
Category 8	7.2Mbps	16QAM,QPSK
Category 9	10.2Mbps	16QAM,QPSK
Category 10	14.4Mbps	16QAM,QPSK
Category 11	0.9Mbps	QPSK
Category 12	1.8Mbps	QPSK
Category 13	17.6Mbps	64QAM
Category 14	21.1Mbps	64QAM
Category 15	23.4Mbps	16QAM
Category 16	28Mbps	16QAM
Category 17	23.4Mbps	64QAM
Category 18	28Mbps	64QAM
Category 19	35.5Mbps	64QAM
Category 20	42Mbps	64QAM
Category 21	23.4Mbps	16QAM
Category 22	28Mbps	16QAM
Category 23	35.5Mbps	64QAM
Category 24	42.2Mbps	64QAM
HSUPA device category	Max data rate (peak)	Modulation type
Category 1	0.96Mbps	QPSK
Category 2	1.92Mbps	QPSK
Category 3	1.92Mbps	QPSK

Category 4	3.84Mbps	QPSK
Category 5	3.84Mbps	QPSK
Category 6	5.76Mbps	QPSK
LTE-FDD device category (Downlink)	Max data rate (peak)	Modulation type
Category 1	10Mbps	QPSK/16QAM/64QAM
Category 2	50Mbps	QPSK/16QAM/64QAM
Category 3	100Mbps	QPSK/16QAM/64QAM
Category 4	150Mbps	QPSK/16QAM/64QAM
Category 5	300Mbps	QPSK/16QAM/64QAM
Category 6	300Mbps	QPSK/16QAM/64QAM
LTE-FDD device category (Uplink)	Max data rate (peak)	Modulation type
Category 1	5Mbps	QPSK/16QAM
Category 2	25Mbps	QPSK/16QAM
Category 3	50Mbps	QPSK/16QAM
Category 4	50Mbps	QPSK/16QAM
Category 5	75Mbps	QPSK/16QAM/64QAM
Category 6	50Mbps	QPSK/16QAM

SIM7906E-PCIE
Confidential

7.2 Related Documents

Table 35: Related Documents

SN	Title	Description
[1]	SIM7906_SIM7912 Series_ AT Command Manual_V1.01.00	SIM79XX_ATC_V1.xx
[2]	ITU-T Draft new recommendation V.25ter	Serial asynchronous automatic dialing and control
[10]	3GPP TS 51.010-1	Digital cellular telecommunications system (Release 5); Mobile Station (MS) conformance specification
[11]	3GPP TS 34.124	Electromagnetic Compatibility (EMC) for mobile terminals and ancillary equipment.
[12]	3GPP TS 34.121	Electromagnetic Compatibility (EMC) for mobile terminals and ancillary equipment.
[13]	3GPP TS 34.123-1	Technical Specification Group Radio Access Network; Terminal conformance specification; Radio transmission and reception (FDD)
[14]	3GPP TS 34.123-3	User Equipment (UE) conformance specification; Part 3: Abstract Test Suites.
[15]	EN 301 908-02 V2.2.1	Electromagnetic compatibility and Radio spectrum Matters (ERM); Base Stations (BS) and User Equipment (UE) for IMT-2000. Third Generation cellular networks; Part 2: Harmonized EN for IMT-2000, CDMA Direct Spread (UTRA FDD) (UE) covering essential requirements of article 3.2 of the R&TTE Directive
[16]	EN 301 489-24 V1.2.1	Electromagnetic compatibility and Radio Spectrum Matters (ERM); Electromagnetic Compatibility (EMC) standard for radio equipment and services; Part 24: Specific conditions for IMT-2000 CDMA Direct Spread (UTRA) for Mobile and portable (UE) radio and ancillary equipment
[17]	IEC/EN60950-1(2001)	Safety of information technology equipment (2000)
[18]	3GPP TS 51.010-1	Digital cellular telecommunications system (Release 5); Mobile Station (MS) conformance specification
[19]	GCF-CC V3.23.1	Global Certification Forum - Certification Criteria
[20]	2002/95/EC	Directive of the European Parliament and of the Council of 27 January 2003 on the restriction of the use of certain hazardous substances in electrical and electronic

		equipment (RoHS)
[21]	Module secondary-SMT-UGD-V1.xx	Module secondary SMT Guidelines
[22]	SIM7100_UART_Application_Note_V0.xx	This document describes how to use UART interface of SIMCom SIM7100 modules.
[23]	SIM7X00 Series_USB AUDIO_Application Note_V1 01	USB AUDIO Application Note
[24]	SIM7100_GPS_Application_Note_V0.01	SIM7100 GPS Application Note
[26]	ANTENNA DESIGN GUIDELINES FOR DIVERSITY RECEIVER SYSTEM	ANTENNA DESIGN GUIDELINES FOR DIVERSITY RECEIVER SYSTEM

SIMCom
Confidential

7.3 Terms and Abbreviations

Table 36: Terms and Abbreviations

Abbreviation	Description
ADC	Analog-to-Digital Converter
ARP	Antenna Reference Point
BER	Bit Error Rate
BTS	Base Transceiver Station
CS	Coding Scheme
CSD	Circuit Switched Data
CTS	Clear to Send
DAC	Digital-to-Analog Converter
DRX	Discontinuous Reception
DSP	Digital Signal Processor
DTE	Data Terminal Equipment (typically computer, terminal, printer)
DTR	Data Terminal Ready
DTX	Discontinuous Transmission
EFR	Enhanced Full Rate
EGSM	Enhanced GSM
EMC	Electromagnetic Compatibility
ESD	Electrostatic Discharge
ETS	European Telecommunication Standard
EVDO	Evolution Data Only
FCC	Federal Communications Commission (U.S.)
FD	SIM fix dialing phonebook
FDMA	Frequency Division Multiple Access
FR	Full Rate
GMSK	Gaussian Minimum Shift Keying
GPRS	General Packet Radio Service
GSM	Global Standard for Mobile Communications
HR	Half Rate
HSPA	High Speed Packet Access
I2C	Inter-Integrated Circuit
IMEI	International Mobile Equipment Identity
LTE	Long Term Evolution
MO	Mobile Originated
MS	Mobile Station (GSM engine), also referred to as TE

MT	Mobile Terminated
PAP	Password Authentication Protocol
PBCCH	Packet Switched Broadcast Control Channel
PCB	Printed Circuit Board
PCS	Personal Communication System, also referred to as GSM 1900
RF	Radio Frequency
RMS	Root Mean Square (value)
RTC	Real Time Clock
SIM	Subscriber Identification Module
SMS	Short Message Service
SPI	serial peripheral interface
SMPS	Switched-mode power supply
TDMA	Time Division Multiple Access
TE	Terminal Equipment, also referred to as DTE
TX	Transmit Direction
UART	Universal Asynchronous Receiver & Transmitter
VSWR	Voltage Standing Wave Ratio
SM	SIM phonebook
NC	Not connect
EDGE	Enhanced data rates for GSM evolution
HSDPA	High Speed Downlink Packet Access
HSUPA	High Speed Uplink Packet Access
ZIF	Zero intermediate frequency
WCDMA	Wideband Code Division Multiple Access
VCTCXO	Voltage control temperature-compensated crystal oscillator
USIM	Universal subscriber identity module
UMTS	Universal mobile telecommunications system
UART	Universal asynchronous receiver transmitter

7.4 Safety Caution

Table 37: Safety caution

Marks	Requirements
	<p>When in a hospital or other health care facility, observe the restrictions about the use of mobiles. Switch the cellular terminal or mobile off, medical equipment may be sensitive to not operate normally for RF energy interference.</p>
	<p>Switch off the cellular terminal or mobile before boarding an aircraft. Make sure it is switched off. The operation of wireless appliances in an aircraft is forbidden to prevent interference with communication systems. Forget to think much of these instructions may lead to the flight safety or offend against local legal action, or both.</p>
	<p>Do not operate the cellular terminal or mobile in the presence of flammable gases or fumes. Switch off the cellular terminal when you are near petrol stations, fuel depots, chemical plants or where blasting operations are in progress. Operation of any electrical equipment in potentially explosive atmospheres can constitute a safety hazard.</p>
	<p>Your cellular terminal or mobile receives and transmits radio frequency energy while switched on. RF interference can occur if it is used close to TV sets, radios, computers or other electric equipment.</p>
	<p>Road safety comes first! Do not use a hand-held cellular terminal or mobile when driving a vehicle, unless it is securely mounted in a holder for hands free operation. Before making a call with a hand-held terminal or mobile, park the vehicle.</p>
	<p>GSM cellular terminals or mobiles operate over radio frequency signals and cellular networks and cannot be guaranteed to connect in all conditions, for example no mobile fee or a invalid SIM card. While you are in this condition and need emergent help, please remember using emergency calls. In order to make or receive calls, the cellular terminal or mobile must be switched on and in a service area with adequate cellular signal strength.</p> <p>Some networks do not allow for emergency call if certain network services or phone features are in use (e.g. lock functions, fixed dialing etc.). You may have to deactivate those features before you can make an emergency call.</p> <p>Also, some networks require that a valid SIM card be properly inserted in the cellular terminal or mobile.</p>