

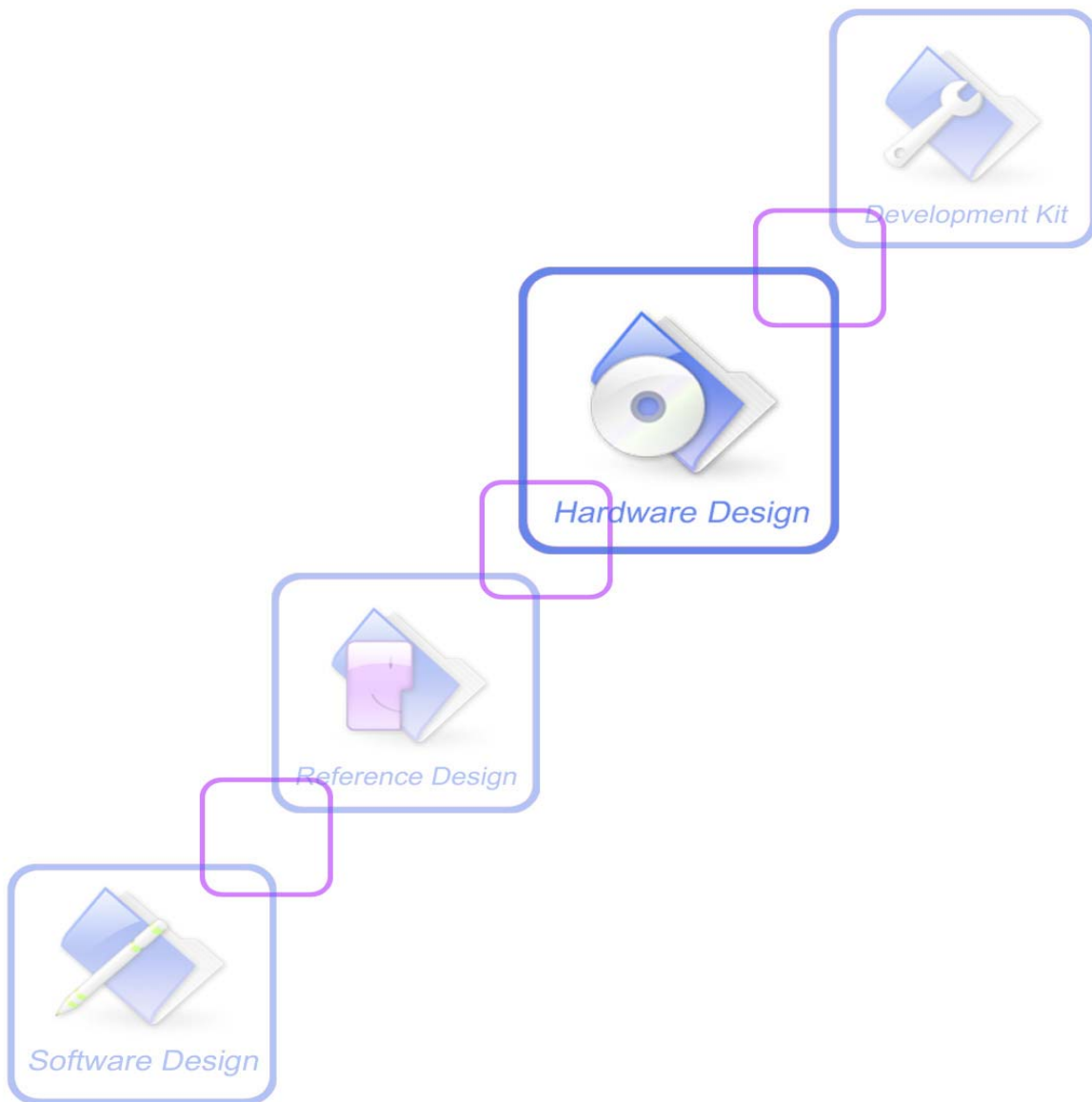

A company of SIM Tech

SIM68M_Hardware Design_V1.04



Document Title	SIM68M Hardware Design
Version	1.04
Date	2015-06-25
Status	Release
Document Control ID	SIM68M_Hardware Design_V1.04

General Notes

SIMCom offers this information as a service to its customers, to support application and engineering efforts that use the products designed by SIMCom. The information provided is based upon requirements specifically provided to SIMCom by the customers. SIMCom has not undertaken any independent search for additional relevant information, including any information that may be in the customer's possession. Furthermore, system validation of this product designed by SIMCom within a larger electronic system remains the responsibility of the customer or the customer's system integrator. All specifications supplied herein are subject to change.

Copyright

This document contains proprietary technical information which is the property of SIMCom Limited, copying of this document and giving it to others and the using or communication of the contents thereof, are forbidden without express authority. Offenders are liable to the payment of damages. All rights reserved in the event of grant of a patent or the registration of a utility model or design. All specification supplied herein are subject to change without notice at any time.

Copyright © Shanghai SIMCom Wireless Solutions Ltd. 2015

Contents

Contents	3
Version History	7
1 Introduction	8
2 SIM68M Overview	8
2.1 SIM68M Functional Diagram	9
2.2 GNSS Performance.....	9
2.3 General features.....	11
3 Package Information	12
3.1 Pin out Diagram.....	12
3.2 Pin Description	12
3.3 Package Dimensions.....	14
3.4 SIM68M Recommended PCB Decal.....	15
4 Application Interface	16
4.1 Power Management	16
4.1.1 Power Input	16
4.1.2 Starting SIM68M	16
4.1.3 Verification of SIM68M Start	16
4.1.4 Power Saving Modes.....	16
4.1.5 Operating Mode	17
4.1.5.1 Full on Mode.....	17
4.1.5.2 Sleep Mode	17
4.1.5.3 Backup Mode	17
4.1.5.4 Periodic Mode.....	18
4.1.6 VCC_RF.....	18
4.1.7 ANTON.....	18
4.2 UART Interface.....	18
4.3 NRESET Input.....	19
4.4 TIMEMARK Output	19
4.5 A-GPS and DGPS.....	20
4.5.1 EPO.....	20
4.5.2 EASY MODE.....	20
4.5.3 DGPS	21
4.6 GNSS Antenna	21
4.6.1 Antenna Interface.....	21
4.6.2 Antenna Choice and RF Design Consideration.....	21
4.6.2.1 Passive Antenna	22
4.6.2.2 Active Antennas.....	23
5 Electrical, Reliability and Radio Characteristics	25
5.1 Absolute Maximum Ratings	25
5.2 Recommended Operating Conditions.....	25
5.3 Electro-Static Discharge	26

6	Manufacturing	27
6.1	Top and Bottom View of SIM68M	27
6.2	Assembly and Soldering.....	27
6.3	Moisture sensitivity	28
6.4	ESD handling precautions	28
6.5	Shipment.....	29
7	Reference Design	29
	Appendix	30
	A. Related Documents.....	30
	B. Terms and Abbreviations	30

SIMCOM CONFIDENTIAL FILE

Table Index

TABLE 1: GNSS PERFORMANCE	9
TABLE 2: GENERAL FEATURES	11
TABLE 3: PIN DESCRIPTION	12
TABLE 4: POWER SUPPLY AND CLOCK STATE ACCORDING TO OPERATION MODE.....	17
TABLE 5: ANTON STATUS.....	18
TABLE 6: PSIMIPR NMEA PORT DATA RATE.....	19
TABLE 7: ANTENNA SPECIFICATIONS.....	22
TABLE 8: ABSOLUTE MAXIMUM RATINGS.....	25
TABLE 9: SIM68M OPERATING CONDITIONS.....	25
TABLE 10: SIM68M STANDARD IO FEATURES.....	25
TABLE 11: THE ESD CHARACTERISTICS (TEMPERATURE: 25°C, HUMIDITY: 45 %)	26
TABLE 12: MOISTURE CLASSIFICATION LEVEL AND FLOOR LIFE	28
TABLE 13: RELATED DOCUMENTS	30
TABLE 14: TERMS AND ABBREVIATIONS.....	30

SIMCOM CONFIDENTIAL FILE

Figure Index

FIGURE 1: SIM68M FUNCTIONAL DIAGRAM.....	9
FIGURE 2: SIM68M PIN OUT DIAGRAM (TOP VIEW)	12
FIGURE 3: SIM68M MECHANICAL DIMENSIONS (UNIT: MM)	14
FIGURE 4: RECOMMENDED PCB DECAL (TOP VIEW) (UNIT: MM).....	15
FIGURE 5: PERIODIC MODE.....	18
FIGURE 6: TIMEMARK APPLICATION CIRCUIT	20
FIGURE 7: SIM68M PASSIVE ANTENNA DESIGN	22
FIGURE 8: SIM68M PASSIVE ANTENNA DESIGN (WITH EXTERNAL LNA AND SAW)	23
FIGURE 9: SIM68M PASSIVE ANTENNA DESIGN FOR BEST PERFORMANCE AND INCREASECD IMMUNITY	23
FIGURE 10: SIM68M ACTIVE ANTENNA DESIGN.....	24
FIGURE 11: SIM68M ACTIVE ANTENNA DESIGN FOR LOW POWER CONSUMPTION	24

SIMCOM CONFIDENTIAL FILE

Version History

Date	Version	Description of change	Author
2014-01-06	V1.00	Origin	Shengwu.Sun Lili.Teng
2014-07-15	V1.01	Update Table 1	Chengbing.Wu
2015-01-19	V1.02	Update Table 1	Chengbing.Wu
2015-03-05	V1.03	Modify the document	Chengbing.Wu Lili.Teng
2015-06-25	V1.04	Update PIN18	Chengbing.Wu

SIMCOM CONFIDENTIAL FILE

1 Introduction

This document describes the hardware interface of the SIMCom module SIM68M which can be used as a stand alone or A-GPS (Assisted Global Positioning System) receiver. As a wide range of applications can be integrated in SIM68M, all functional components of SIM68M are described in great detail.

2 SIM68M Overview

SIM68M is a stand-alone or A-GPS receiver. With built-in LNA, SIM68M don't need for external LNA. SIM68M can track as low as -165dBm signal even without assistance network (up to 45dB C/N of SVs in open sky). SIM68M has excellent low power consumption characteristic. SIM68M supports various location and navigation applications, including autonomous GPS/GLONASS/QZSS/SBAS (WAAS, EGNOS, GAGAN, MSAS), DGPS and A-GPS.

Key Features

- Receiver 33tracking/99 acquisition-channel, up to 210 PRN channels
- Small footprint: 10 .1x 9.7 x 2.5mm, 18-pin LCC package
- 12 multi-tone active interference cancellers and jamming elimination⁽¹⁾
- Indoor and outdoor multi-path detection and compensation
- Max NMEA update rate up to 10 Hz⁽²⁾
- Advanced software features
 1. EASY self-generated orbit prediction for instant positioning fix
 2. AGPS Support for Fast TTFF(EPO/HotStill orbit prediction)
 3. AlwaysLocate advanced location awareness technology for power saving
 4. Supports logger function
 5. Supports active interference cancellation (AIC)
- Pulse-per-second (PPS) GPS time reference
 1. Adjustable duty cycle
 2. typical accuracy: $\pm 10\text{ns}$
 - i. Interface UART0/ UART1⁽⁴⁾
- Operating ^{tem}perature: -40 ~ +85°C
- Accuracy <2.5m CEP
- RoHS compliant

(1) AIC is default open after the software version of B03V20, and it can be controlled by PMTK command, see document [2] for details.

(2) Default is 1 Hz.

(3) RTCM function.

The module provides complete signal processing from antenna input to host port in either NMEA messages. The module requires 2.8V~4.3V power supply. The host port is configurable to UART. Host data and I/O signal levels are 2.85V CMOS compatible.

2.1 SIM68M Functional Diagram

The following figure shows a functional diagram of the SIM68M and illustrates the mainly functional parts:

- The GNSS chip
- SAW filter
- LNA
- The antenna interface
- The communication interface
- The control signals

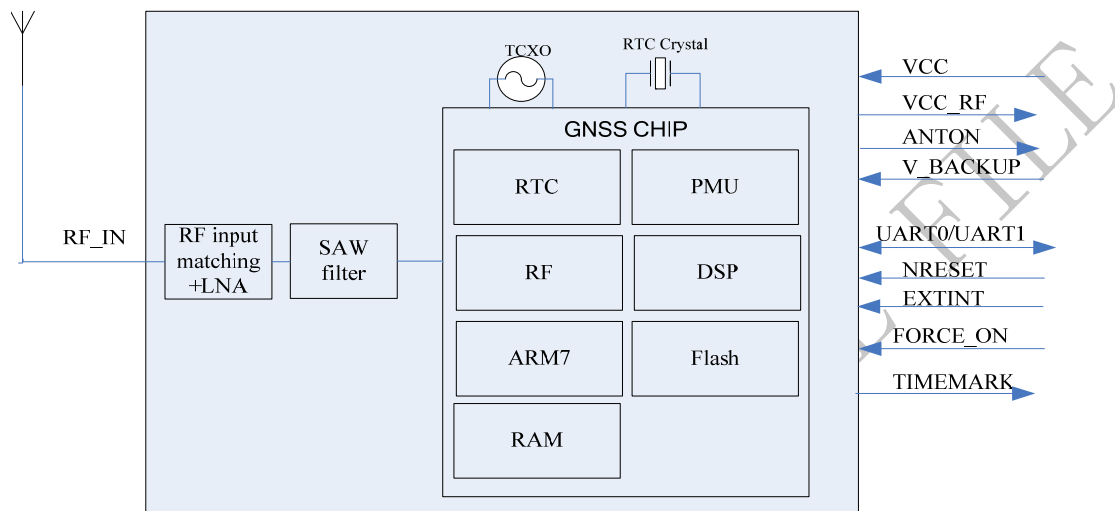

Figure 1: SIM68M functional diagram

2.2 GNSS Performance

Table 1: GNSS performance

Parameter	Description	Performance			
		Min	Type	Max	Unit
Horizontal Position Accuracy ⁽¹⁾	Autonomous		<2.5		m
Velocity Accuracy ⁽²⁾	Without Aid		0.1		m/s
	DGPS		0.05		m/s
Acceleration Accuracy	Without Aid		0.1		m/s ²
	DGPS		0.05		m/s ²
Timing Accuracy			10		ns
Dynamic Performance	Maximum Altitude			18000	m
	Maximum Velocity			515	m/s
	Maximum Acceleration			4	G
GPS Time To First Fix ⁽³⁾	Hot start		<1		s
	Warm start		32.3		s
	Cold start		32.3		s

GLONASS Time To First Fix ⁽³⁾	Hot start		<1		s
	Warm start		29.6		s
	Cold start		30.7		s
GPS+GLONASS Time To First Fix ⁽³⁾	Hot start		<1		s
	Warm start		22.8		s
	Cold start		25		s
A-GPS TTFF(EASY mode)	Hot start		<1		s
	Warm start		1.2		s
	Cold start		14.9		s
A-GPS TTFF(EPO mode)	Hot start		<1		s
	Warm start		1.4		s
	Cold start		13.3		s
GPS Sensitivity ⁽⁷⁾	Autonomous acquisition(cold start)		-148		dBm
	Re-acquisition		-160		dBm
	Tracking		-165		dBm
GLONASS Sensitivity ⁽⁷⁾	Autonomous acquisition(cold start)		-147		dBm
	Re-acquisition		-153		dBm
	Tracking		-158		dBm
GPS+GLONASS Sensitivity ⁽⁷⁾	Autonomous acquisition(cold start)		-148		dBm
	Re-acquisition		-160		dBm
	Tracking		-166		dBm
Receiver	Channels		132		
	Update rate		1	10	Hz
	Tracking L1, CA Code				
	Protocol support NMEA,PMTK				
GPS Power consumption ⁽⁴⁾	Acquisition		26		mA
	Continuous tracking		22		mA
	Sleep current		350		uA
	Backup current		8		uA
GLONASS Power consumption ⁽⁵⁾	Acquisition		25		mA
	Continuous tracking		21		mA
	Sleep current		350		uA
	Backup current		8		uA
GPS+GLONASS Power consumption ⁽⁶⁾	Acquisition		27		mA
	Continuous tracking		22		mA
	Sleep current		350		uA
	Backup current		8		uA

(1) 50% 24hr static, -130dBm

- (2) 50% at 30m/s
- (3) -130 dBm, GPS&GLONASS mode
- (4) Single Power supply 3.3V under GPS+GLONASS signal@-130dBm
- (5) Single Power supply 3.3V under GPS signal@-130dBm
- (6) Single Power supply 3.3V under GLONASS signal@-130dBm
- (7) Single Power supply 3.3V under GPS+GLONASS signal

2.3 General features

Table 2: General features

Parameters		Value
Supply voltage VCC		+2.8V~4.3V
Supply voltage ripple VCC		54 mV(RMS) max @ f = 0~3MHz 15 mV(RMS) max @ f > 3 MHz
Power consumption(acquisition)		27mA type. @ VCC=3.3 V
Power consumption(sleep)		350uA type. @ VCC=3.3 V
Storage temperature		-40°C~+85°C
Operating temperature		-40°C~+85°C (note 1)
I/O signal levels	V _{IL}	-0.3V~0.8V
	V _{IH}	2.0V~3.3V
	V _{OL}	-0.3V~0.4V
	V _{OH}	2.4V~3.1V
I/O output sink/source capability		+/- 3mA max
I/O input leakage		+/- 10 uA max
Host port		UART0
Serial port protocol (UART)		NMEA; 8 bits, no parity, 1 stop bit; 115200 baud (configurable)
TIMEMARK output (1PPS)		1 pulse per second, synchronized at rising edge, pulse length 100ms

Note 1: Operation in the temperature range -40°C~ -30°C is allowed but Time-to-First-Fix performance and tracking sensitivity may be degraded.

3 Package Information

3.1 Pin out Diagram

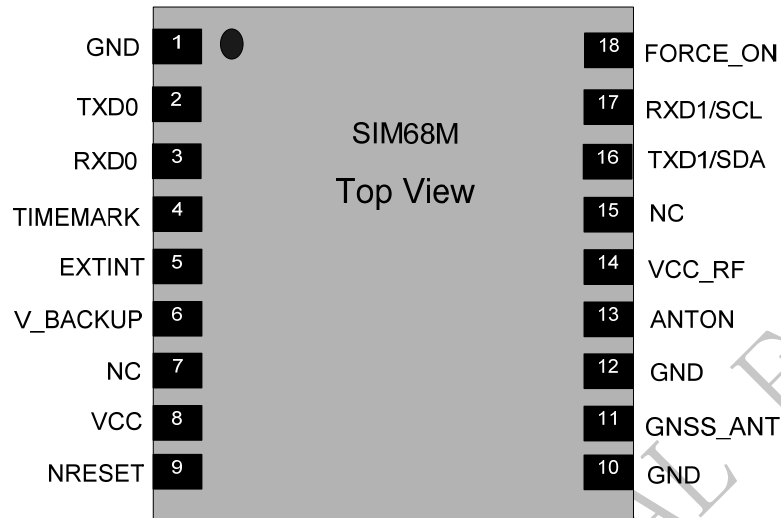

Figure 2: SIM68M pin out diagram (Top view)

3.2 Pin Description

Table 3: Pin description

Pin name	Pin number	I/O	Description	Comment
Power supply				
VCC	8	I	Main power input, which will be used to power the baseband and RF section internally. The Vcc ripple must be controlled under 54mV pp (Typical: 3.3V)	Provide clean and stable power source to this pin. Add a 4.7uF capacitor to this pin for decoupling.
ANTON	13	O	2.8V power output supply for active antenna or external LNA control pin for power save	If unused, keep open.
VCC_RF	14	O	Power supply for active antenna or external LNA	If unused, keep open
V_BACKUP	6	I/O	The backup battery input power supply for RTC 2.0V~4.3V, Typical 3.0V	If unused, keep open.
GND	1,10,12		Ground	GND

Host port interface				
TXD0	2	O	Serial data output of NMEA	
RXD0	3	I	Serial data input for firmware update	
TXD1/SDA	16	I/O	Serial output as RTCM	I2C requires a special version, please contact SIMCom
RXD1/SCL	17	I	Serial input as RTCM	
GPIOs				
TIMEMARK	4	O	1PPS Time Mark Output 2.85V CMOS Level ,timing pulse related to receiver time	If unused, keep open.
NRESET	9	I	Reset input, active low,default pull-up	If unused, keep open.
EXTINT	5	I	This interrupt source could act as wake up event during power saving mode.	If unused, keep open .
FORCE_ON	18	I	Logic high will Force module to be waked up from backup mode	Keep this pin open or pulled low before Entering into backup mode. If unused, keep open
RF interface				
GNSS_ANT	11	I	GNSS antenna port	Impedence must be controlled to 50Ω.
Other interface				
NC	7,15,		Not Connected	

SIMCOM CONFIDENTIAL

3.3 Package Dimensions

Following figure shows the Mechanical dimensions of SIM68M (top view, side view and bottom view).

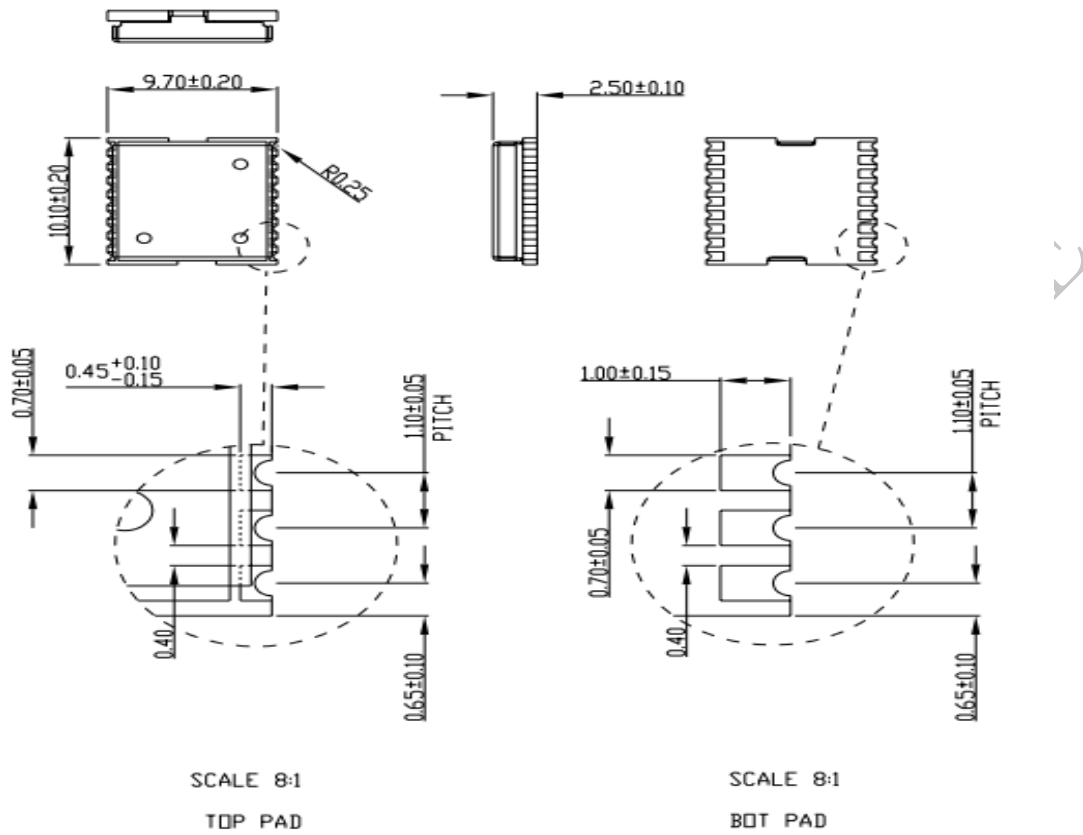

Figure 3: SIM68M mechanical dimensions (Unit: mm)

3.4 SIM68M Recommended PCB Decal

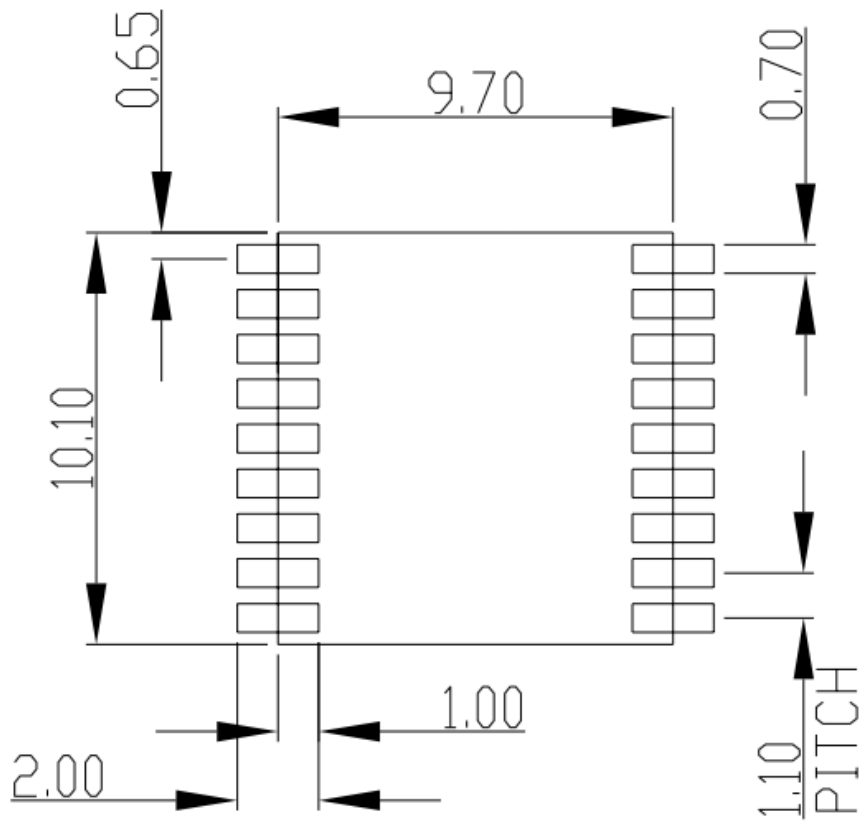

Figure 4: Recommended PCB decal (top view) (Unit: mm)

4 Application Interface

4.1 Power Management

4.1.1 Power Input

The power supply range of SIM68M is from 2.8V to 4.3V. The power supply should be able to provide sufficient current up to 100mA.

The power supply range of V_BACKUP is from 2.0V to 4.3V, typical 3.0V, suggesting customer keep the V_BACKUP supply active all the time, module will perform a quick start every time it is power-on.

Note: IF VBACKUP power was not reserved, the GPS module will perform a lengthy cold start every time it is powered - on because previous satellite information is not retained and needs to be re-transmitted

4.1.2 Starting SIM68M

When power is first applied, SIM68M goes into operation mode.

4.1.3 Verification of SIM68M Start

System activity indication depends upon the chosen serial interface: When it is activated, SIM68M will output messages at the selected UART speed and message types.

4.1.4 Power Saving Modes

SIM68M supports operating modes for reduced average power consumption like standby mode, backup mode, periodic mode, and AlwaysLocate™ mode.

- **Sleep mode:** In this mode the receiver stays at full on power state. When this mode that can be wake up by the host sends the command through the communication interface. It also describe called Standby mode,

Note: using the PMTK161 command

*"\$PMTK161,0*28" Stop mode;*

*"\$PMTK161,1*29" into Sleep mode; but also to stop the NMEA output; Serial any character, the StandbyPin pin can rise along the wake, wake up after the longer dormancy.*

'0' = Stop mode, stop NMEA output, the receiver stays at ultra low power state

'1' = Sleep mode, stop NMEA output, the receiver stays at full on power state

- **Backup mode:** In this mode the SIM68M must be supplied by the backup and it can help to count down the time for backup mode. Software on host side to send the command through the communication interface.

*Note: backup mode, the first "\$PMTK225,0*2B" again "\$PMTK225,4*2F" into a permanent backup mode, cannot be serial, StandbyPin pin wake.*

- **Periodic mode:** In this mode the SIM68M enters tracking and sleep or Backup mode according to the interval configured.

Note: Also called Period Standby mode, note: using the PMTK225 command

*"\$PMTK225,0*2B"*

*"\$PMTK223,1,2518000060000*38"*

"\$PMTK225,23000120001800072000*15"

Run for 3 seconds, 12 seconds of sleep, so the cycle; be serial any string after awakening was no longer dormancy,

StandbyPin can continue into periodic sleep state after awakening

- AlwaysLocate™ mode: AlwaysLocate™ is an intelligent controller of SIM68M periodic mode. Depending on the environment and motion conditions, SIM68M can adaptive adjust the on/off time to achieve balance of positioning accuracy and power consumption.

Note: AlwaysLocate™ Standby

"\$PMTK225,0 " "\$PMTK225,8 "

AlwaysLocate™ Backup"

"\$PMTK225,0 " "\$PMTK225,9"

8': AlwaysLocate™ standby mode

9': AlwaysLocate™ backup mode

Note: the modes mentioned above are operated by PMTK commands, users can refer to document [1] for more information.

4.1.5 Operating Mode

Table 4: Power supply and clock state according to operation mode

Mode	VCC	V_BACKUP	Internal LDO	Main clock	RTC clock
Full on	on	on	on	on	on
Sleep	on	on	on	off	on
Backup	on	on	off	off	on

4.1.5.1 Full on Mode

The module will enter full on mode after first power up with factory configuration settings. Power consumption will vary depending on the amount of satellite acquisitions and number of satellites in track.

4.1.5.2 Sleep Mode

Sleep mode means a low quiescent (350uA type.) power state, non-volatile RTC, and backup RAM block is powered on. Other internal blocks like digital baseband and RF are internally powered off. The power supply input VCC shall be kept active all the time, even during sleep mode.

Entering into sleep mode is sent PMTK command through the communication interface by host side.

Waking up from sleep mode is sent any byte through the communication interface by host side.

4.1.5.3 Backup Mode

This connects to the backup power of the module. Power source (such as battery or cap) connected to V_BACKUP pin will help the chipset in keeping its internal RTC running when the VCC power source is turned off. The voltage should be kept between 2.0~4.3V, Typical 3.0V.

The V_BACKUP power should be kept active all the time, the module will perform a quick start every time it is power-on.

4.1.5.4 Periodic Mode

In this mode the SIM68M enters tracking and sleep or Backup mode according to the interval configured by users in the commands.

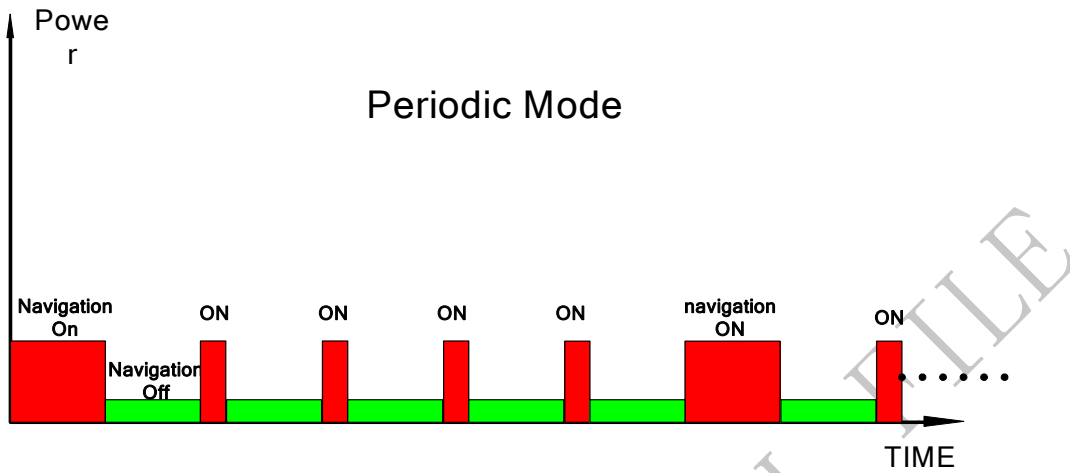

Figure 5: Periodic Mode

4.1.6 VCC_RF

Power supply for active antenna or external LNA, the power domain is VCC

4.1.7 ANTON

2.8V power output for active antenna or external LNA control pin for power save. See the following table for details.

Table 5: ANTON Status

Mode	ANTON
Full on	2.8V power output
Sleep	no power output
Backup	no power output

4.2 UART Interface

SIM68M includes two UART (UART0 and UART1) interface for serial communication. The UART0 is as NMEA output and PMTK command input. The receiver (RXD0) and transmitter (TXD0) side of every port contains a 16-byte FIFO and has 256 bytes URAM. UART can provide the developers signal or message outputs. The baud rates are selectable and ranging from 4.8 to 921.6kbps through PMTK commands, see the following table for details. UART1 is as RTCM input.

Note: the UART1 can also used to be as I2C port for NMEA communication, this function requires a special version, please contact SIMCom.

Table 6: PSIMIPR NMEA port data rate

PSIMIPR NMEA port data rate	
Example: \$PSIMIPR,W,115200*1C	
Test Command PSIMIPR,T	Response PSIMIPR,T,(0,4800,9600,14400,19200,38400,57600,115200) Parameters See Write Command
Write Command PSIMIPR,W,<baud rate>	Response If success, return : PSIMIPR,W,Ok If error, return : PSIMIPR,W,Error Parameters <baud rate> support default baud rate(0) or 4800,9600,14400,19200,38400,57600,115200
Read Command PSIMIPR,R	Response TA returns the current debug information output control PSIMIPR,R,Ok, < baud rate> Parameters See Write Command

Note:

1. 0 refer to firmware default baud rate.
2. Need module reset or Cold/Warm/Hot/Full cold restart to take effect.

4.3 NRESET Input

The NRESET pin (active low) is used to reset the system, normally external control of NRESET is not necessary. The signal can be left floating, if not used.

When NRESET signal is used, it will force volatile RAM data loss. Note that Non-Volatile backup RAM content is not cleared and thus fast TTFB is possible. The input has internal pull up.

4.4 TIMEMARK Output

The TIMEMARK pin outputs one pulse-per-second (1PPS) pulse signal for precise timing purposes. The TIMEMARK signal can be provided through designated output pin for many external applications. This pulse is not only limited to be active every second but also allowed to set the required duration, frequency, and active high/low by programming user-defined settings.

The following figure is the typical application of the TIMEMARK function.

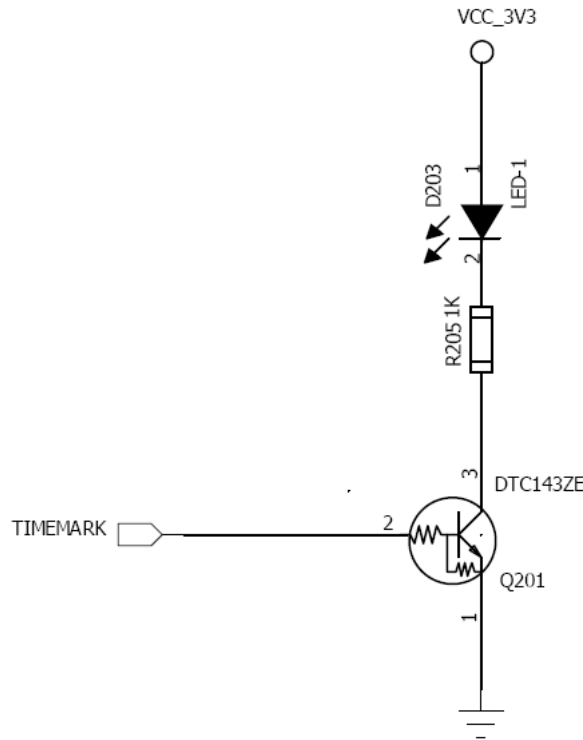

Figure 6: TIMEMARK application circuit

4.5 A-GPS and DGPS

A-GPS is the meaning of Assisted GPS, which is a system that can improve the startup performance and time-to-first-fix (TTFF) of a GPS satellite-based positioning under certain conditions. SIM68M module supports EPO file, EASY MODE.

4.5.1 EPO

The SIM68M supports the EPO (Extended Prediction Orbit) data service. The EPO data service is supporting 7/14/30-day orbit predictions to customers. It needs occasional download from EPO server. Supply of aiding information like ephemeris, almanac, rough last position and time and satellite status and an optional time synchronization signal will reduce time to first fix significantly and improve the acquisition sensitivity.

The user should update the EPO files from the EPO server daily through the internet. Then the EPO data should send to the SIM68M by the HOST side. SIM68M has the short cold TTFF and warm TTFF, when the A-GPS is used.

Note: For more information about EPO, please contact SIMCom sales. Users can refer to document [2] for more information

4.5.2 EASY MODE

EASY is the abbreviation of Embedded Assist System, it works as embedded firmware which accelerates TTFF by predicting satellite navigation messages from received ephemeris.

No additional computing interval for EASY task. EASY is efficiently scheduled and computed in free time of every second after GPS navigation solution.

EASY function is conceptually designed to automatically engage for predicting after first receiving the broadcast ephemeris. After a while (generally tens of seconds), 3-day extensions will be completely generated then all EASY functions will be maintained at a sleep condition. EASY assistance is going to be engaged when the GPS requests in new TTFF condition or re-generates again with another new received ephemeris. Meanwhile, TTFF will be benefited by EASY assistance.

Note: EASY function is default open and can be closed by PMTK command.

4.5.3 DGPS

SBAS is the abbreviation of Satellite Based Augmentation System. The SBAS concept is based on the transmission of differential corrections and integrity messages for navigation satellites that are within sight of a network of reference stations deployed across an entire continent. SBAS messages are broadcast via geostationary satellites able to cover vast areas.

Several countries have implemented their own satellite-based augmentation system. Europe has the European Geostationary Navigation Overlay Service (EGNOS) which covers Western Europe and beyond. The USA has its Wide Area Augmentation System (WAAS). Japan is covered by its Multi-functional Satellite Augmentation System (MSAS). India has launched its own SBAS program named GPS and GEO Augmented Navigation (GAGAN) to cover the Indian subcontinent.

SIM68M module supports SBAS and RTCM, but only one mode can be applied at one time, and SBAS is the default feature, customers who want to apply RTCM in the design can contact SIMCom sales for supporting

4.6 GNSS Antenna

The antenna is a critical item for successful GNSS reception in a weak signal environment. Proper choice of the antenna will ensure that satellites at all elevations can be seen, and therefore, accurate fix measurements are obtained.

User can choose an appropriate antenna for better performance, like active antenna or passive antenna.

4.6.1 Antenna Interface

The SIM68M receives L1 band signals from GPS and L1 band signals from GLOSNASS satellites at a nominal frequency of 1574~1616MHz. The RF signal is connected to the GNSS_ANT pin. And the trace from the GNSS_ANT pin to antenna should be 50Ω controlled.

To suit the physical design of individual applications the RF interface pad can lead to two alternatives:

- Recommended approach: solderable RF coaxial cable assembly antenna connector, such as HRS' U.FL-R-SMT(10) connector or I-PEX's 20279-001E-01 RF connector.
- SMA connector.

4.6.2 Antenna Choice and RF Design Consideration

To obtain excellent GNSS reception performance, a good antenna will always be required. Proper choice and placement of the antenna will ensure that satellites at all elevations can be seen, and therefore, accurate fix

measurements are obtained.

Compare the active antenna and passive antenna as follow:

Table 7: Antenna Specifications

Parameter	Specification	
Passive Antenna Recommendations	Frequency range	1574—1616MHz
	Polarization	RHCP & Linear
	Gain	> 0dBi
Active Antenna Recommendations	Frequency range	1574—1616MHz
	Polarization	RHCP & Linear
	Noise Figure	< 1.5dB
	Gain	>10dBi

4.6.2.1 Passive Antenna

Passive antenna contains only the radiating element, e.g. the ceramic patch, the helix structure, and chip antenna. Sometimes it also contains a passive matching network to match the electrical connection to 50Ω impedance.

The most common antenna type for GNSS applications is the patch antenna. Patch antennas are flat, generally have a ceramic and metal body and are mounted on a metal base plate.

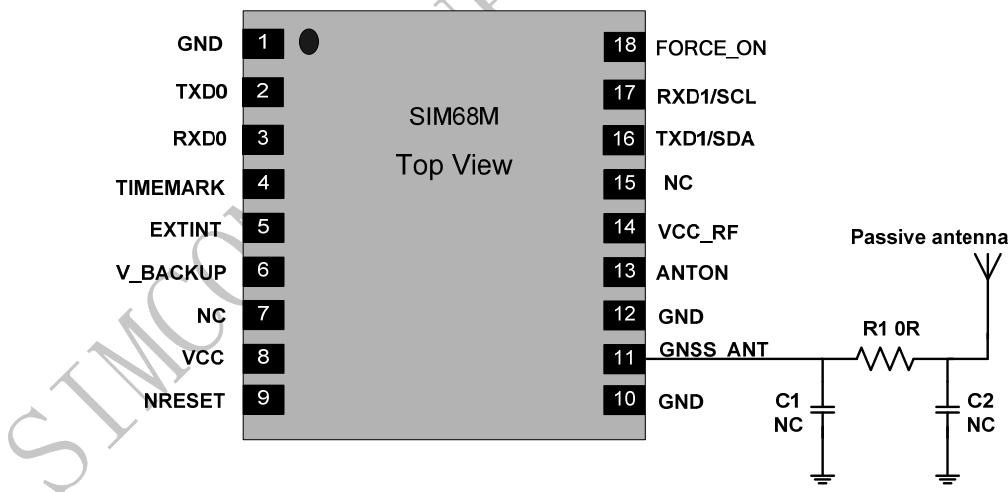

Figure 7: SIM68M passive antenna design

If the passive antenna is far away from SIM68M, and the path loss is over 3dB, customers can use an external LNA to get a better performance. Please see Figure 8.

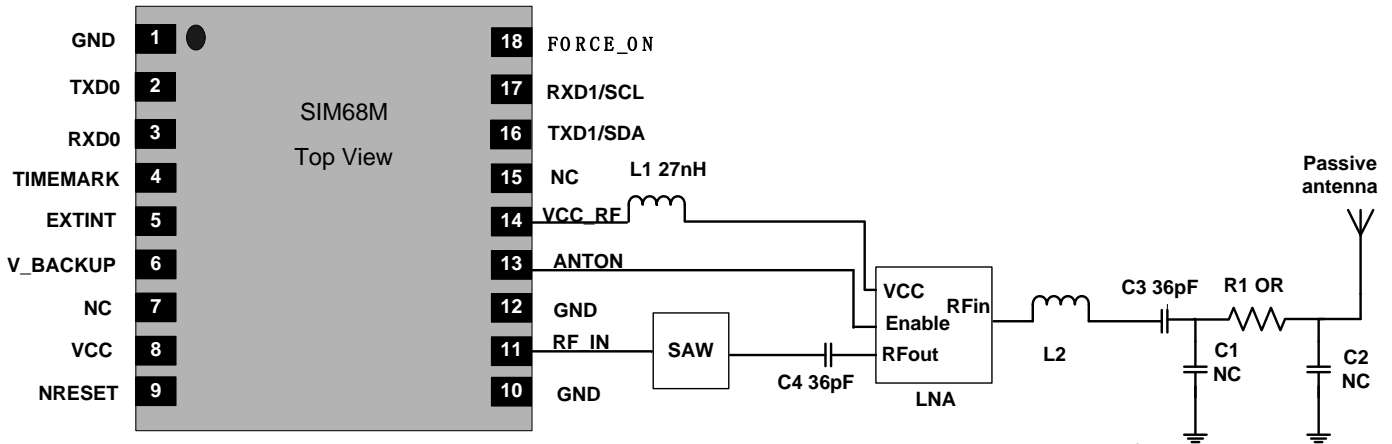

Figure 8: SIM68M passive antenna design (with external LNA and SAW)

User can also use a SAW filter ahead of the external LNA to filtering noises, which could get a better performance in a complex environment. Please see Figure 9.

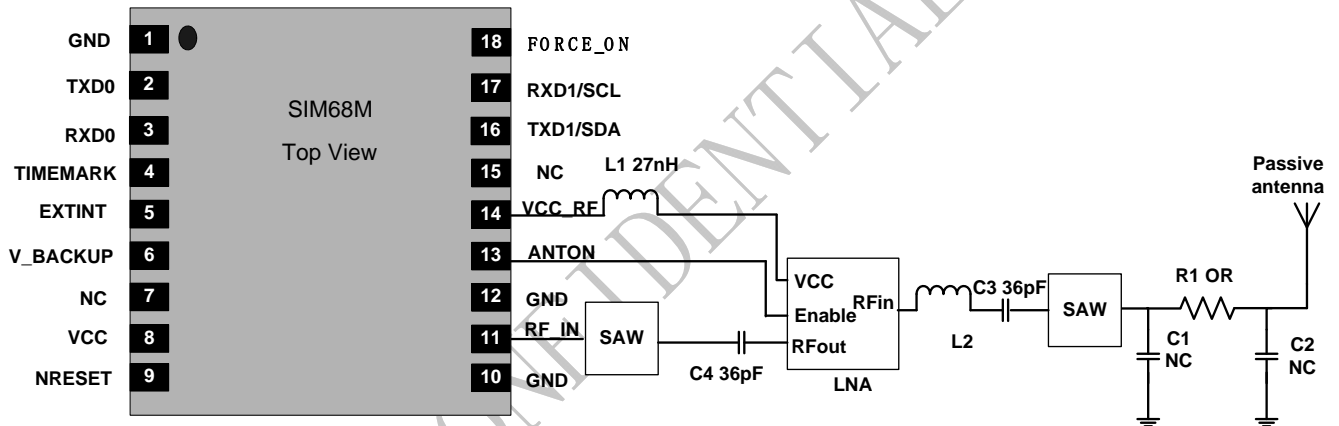

Figure 9: SIM68M passive antenna design for best performance and increase Cd immunity

4.6.2.2 Active Antennas

Active antennas have an integrated Low-Noise Amplifier (LNA). Active antennas need a power supply that will contribute to GNSS system power consumption.

Usually, the supply voltage is fed to the antenna through the coaxial RF cable shown as Figure 10. The output voltage of PIN 14 is 2.8V. If the supply voltage of active antenna is 2.8V, PIN 14 VCC_RF can be connected to RF_IN as figure 9 shows. If the active antenna is not 2.8V, other power should be connected to RF_IN.

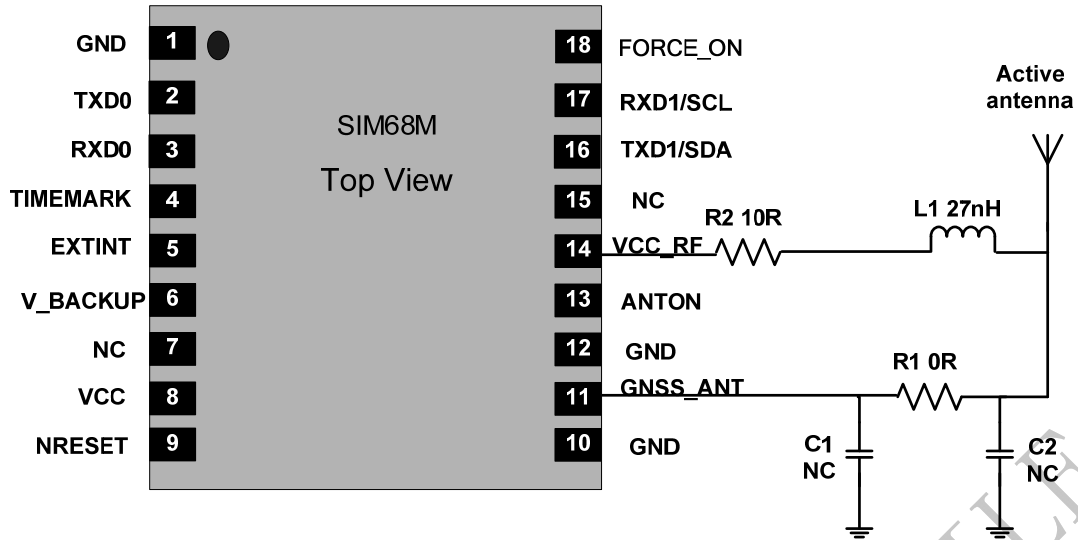

Figure 10: SIM68M Active antenna design

User can use PIN13 ANTION to disable the power supply for external active antenna, which could decrease the power consumption when SIM68M in sleep mode. Please see Figure 11.

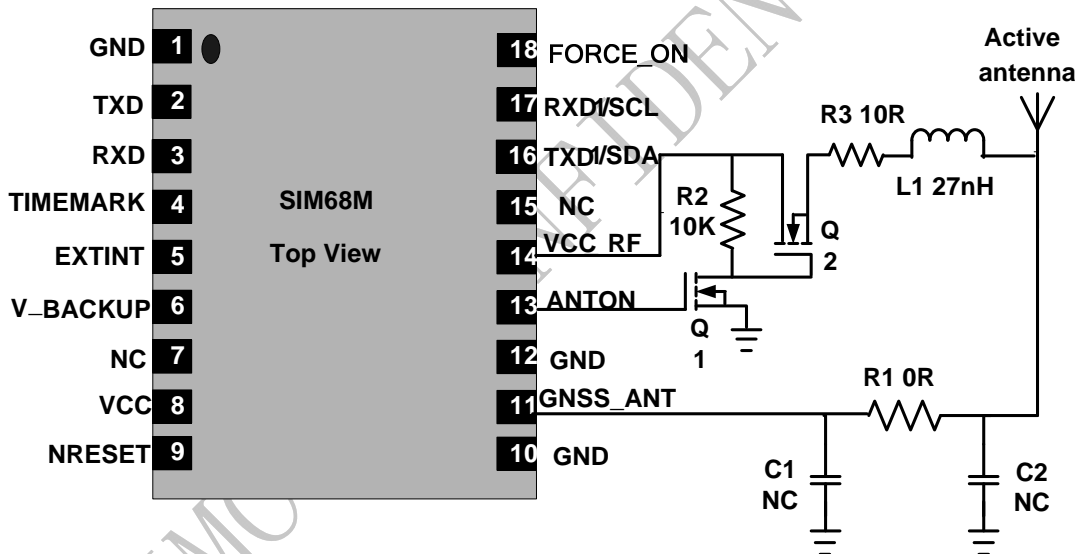

Figure 11: SIM68M active antenna design for low power consumption

If the customer’s design is for automotive applications, then an active antenna can be used and located on C of the car in order to guarantee the best signal quality.

GNSS antenna choice should base on the designing product and other conditions. For detailed Antenna designing consideration, please refer to related antenna vendor’s design recommendation. The antenna vendor will offer further technical support and tune their antenna characteristic to achieve successful GNSS reception performance depending on the customer’s design.

5 Electrical, Reliability and Radio Characteristics

5.1 Absolute Maximum Ratings

The absolute maximum ratings stated in Table 8 are stress ratings under non-operating conditions. Stresses beyond any of these limits will cause permanent damage to SIM68M.

Table 8: Absolute maximum ratings

Parameter	Min	Max	Unit
VCC	-	4.3	V
VCC_RF		VCC	V
ANTON		+2.9	V
Input Power at GNSS_ANT	-	-12	dBm
V_BACKUP	-	4.3	V
I/O pin voltage	-	3.6	V
Storage temperature	-45	+125	°C
Operating Temperature	-40	+85	°C

5.2 Recommended Operating Conditions

Table 9: SIM68M operating conditions

Parameter	Symbol	Min	Typ	Max	Unit
Operating temperature range		-40	+25	+85	°C
Main supply voltage	VCC	2.8	3.3	4.3	V
Backup battery voltage	V_BACKUP	2.0	3	4.3	V

Table 10: SIM68M standard IO features

Parameter	Symbol	Min	Typ	Max	Unit
Low level output voltage Test conditions $I_{OL} = 2\text{mA}$ and 4.0mA	V_{OL}	-	0	0.40	V
High level output voltage Test conditions $I_{OL} = 2\text{mA}$ and 4.0mA	V_{OH}	2.4	2.8		V
Low level input voltage	V_{IL}	-0.3		0.8	V
High level input voltage	V_{IH}	2.0		3.6	V
Input Pull-up resistance	R_{PU}	40		190	K Ω
Input Pull-down resistance	R_{PD}	40		190	K Ω
Input capacitance	C_{IN}		5		pF
Load capacitance	C_{load}			8	pF
Tri-state leakage current	I_{OZ}	-10		10	uA

5.3 Electro-Static Discharge

The GPS engine is not protected against Electrostatic Discharge (ESD) in general. Therefore, it is subject to ESD handling precautions that typically apply to ESD sensitive components. Proper ESD handling and packaging procedures must be applied throughout the processing, handling and operation of any application using a SIM68M module. The ESD test results are shown in the following table.

Table 11: The ESD characteristics (Temperature: 25°C, Humidity: 45 %)

Pin	Contact discharge	Air discharge
VCC	±5KV	±10KV
GNSS_ANT	±5KV	±10KV
V_BACKUP	±5KV	±10KV
ANTON	±5KV	±10KV
VCC_RF	±5KV	±10KV
GND	±5KV	±10KV
RXD0, TXD0	±4KV	±8KV
NRESET	±4KV	±8KV
TIMEMARK	±4KV	±8KV

SIMCOM CONFIDENTIAL

6 Manufacturing

6.1 Top and Bottom View of SIM68M

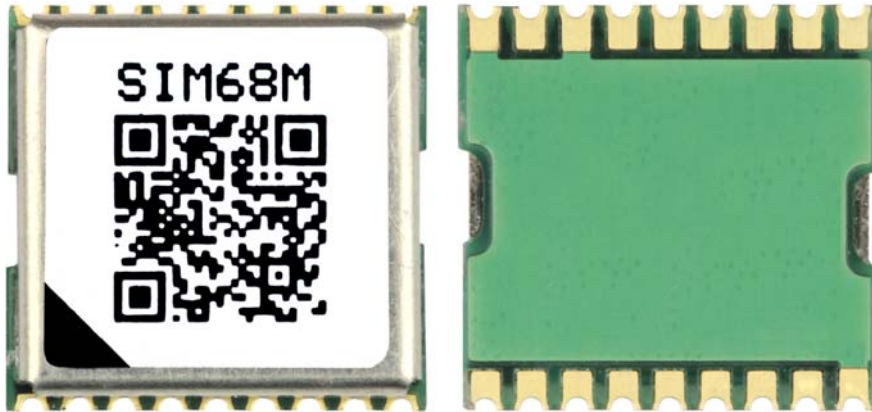

Figure 12: Top and bottom view of SIM68M

6.2 Assembly and Soldering

The SIM68M module is intended for SMT assembly and soldering in a Pb-free reflow process on the top side of the PCB. Suggested solder paste stencil height is 150um minimum to ensure sufficient solder volume. If required paste mask pad openings can be increased to ensure proper soldering and solder wetting over pads.

The following figure is the Ramp-Soak-Spike Reflow Profile of SIM68M:

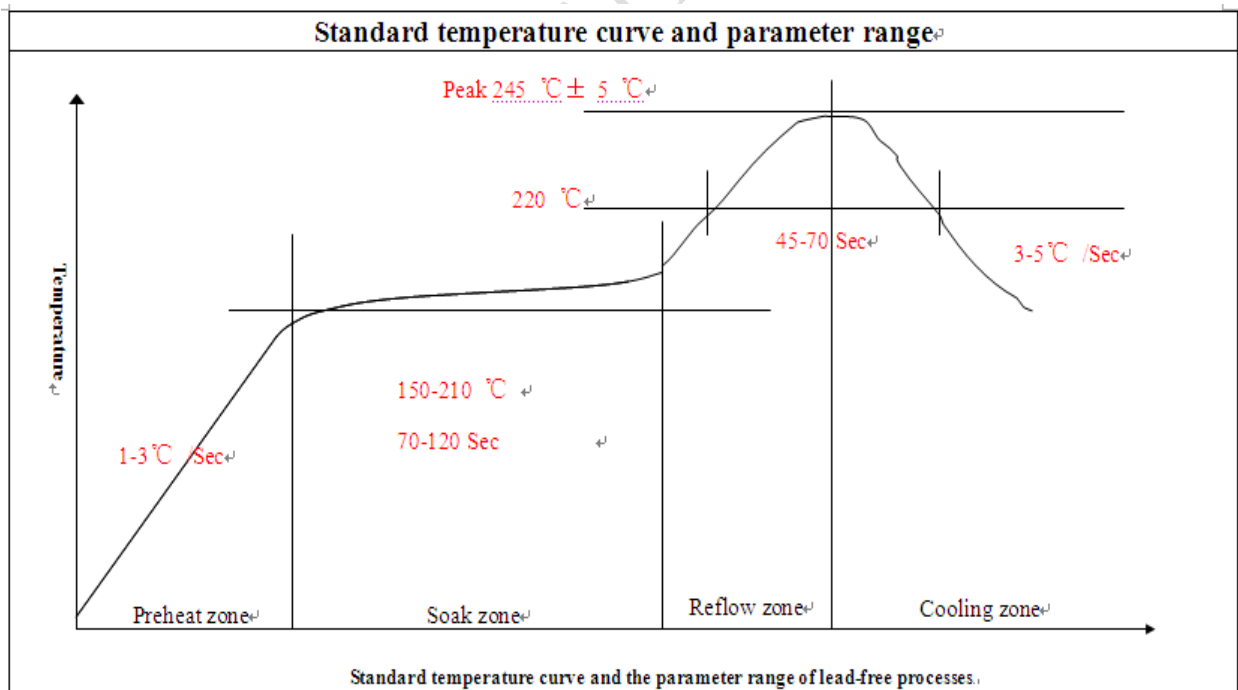

Figure 13: The Ramp-Soak-Spike reflow profile of SIM68M

SIM68M is Moisture Sensitive Devices (MSD), appropriate MSD handling instruction and precautions are summarized in Chapter 6.3.

ESD protection may destroy or damage them permanently.

Avoid ultrasonic exposure due to internal crystal and SAW components.

6.3 Moisture sensitivity

SIM68M module is moisture sensitive at MSL 3, dry packed according to IPC/JEDEC specification J-STD-020C. The calculated shelf life for dry packed SMD packages is a minimum of 6 months from the bag seal date, when stored in a non condensing atmospheric environment of <40°C/90% RH.

Table 12 lists floor life for different MSL levels in the IPC/JDEC specification:

Table 12: Moisture Classification Level and Floor Life

Level	Floor Life(out of bag)at factory ambient \cong +30°C/60%RH or as stated
1	Unlimited at \cong +30°C/85% RH
2	1 year
2a	4 weeks
3	168 hours
4	72 hours
5	48 hours
5a	24 hours
6	Mandatory bake before use. After bake, module must be reflowed within the time limit specified on the label.

Factory floor life is 1 week for MSL 3, SIM68M must be processed and soldered within the time. If this time is exceeded, the devices need to be pre-baked before the reflow solder process.

Both encapsulate and substrate materials absorb moisture. IPC/JEDEC specification J-STD-020 must be observed to prevent cracking and delamination associated with the "popcorn" effect during reflow soldering. The popcorn effect can be described as miniature explosions of evaporating moisture. Baking before processing is required in the following case:

- Floor life or environmental requirements after opening the seal have been exceeded, e.g. exposure to excessive seasonal humidity.

Refer to Section 4 of IPC/JEDEC J-STD-033 for recommended baking procedures.

Notes: Oxidation Risk: Baking SMD packages may cause oxidation and/or inter metallic growth of the terminations, which if excessive can result in solder ability problems during board assembly. The temperature and time for baking SMD packages are therefore limited by solder ability considerations. The cumulative bake time at a temperature greater than 90°C and up to 125°C shall not exceed 96 hours.

6.4 ESD handling precautions

SIM68M modules are Electrostatic Sensitive Devices (ESD). Observe precautions for handling!

Failure to observe these precautions can result in severe damage to the GPS receiver!



GPS receivers are Electrostatic Sensitive Devices (ESD) and require special precautions when handling. Particular

care must be exercised when handling patch antennas, due to the risk of electrostatic charges. In addition to standard ESD safety practices, the following measures should be taken into account whenever handling the receiver:

Unless there is a galvanic coupling between the local GND (i.e. the work Table) and the PCB GND, then the first point of contact when handling the PCB shall always be between the local GND and PCB GND.

Before mounting an antenna patch, connect ground of the device

When handling the RF pin, do not come into contact with any charged capacitors and be careful when contacting materials that can develop charges (e.g. patch antenna ~10pF, coax cable ~50-80pF/m, soldering iron, ...)

To prevent electrostatic discharge through the RF input, do not touch the mounted patch antenna.

When soldering RF connectors and patch antennas to the receiver's RF pin, the user must make sure to use an ESD safe soldering iron (tip).

6.5 Shipment

SIM68M is designed and packaged to be processed in an automatic assembly line, and it is now packaged tray and reel.

7 Reference Design

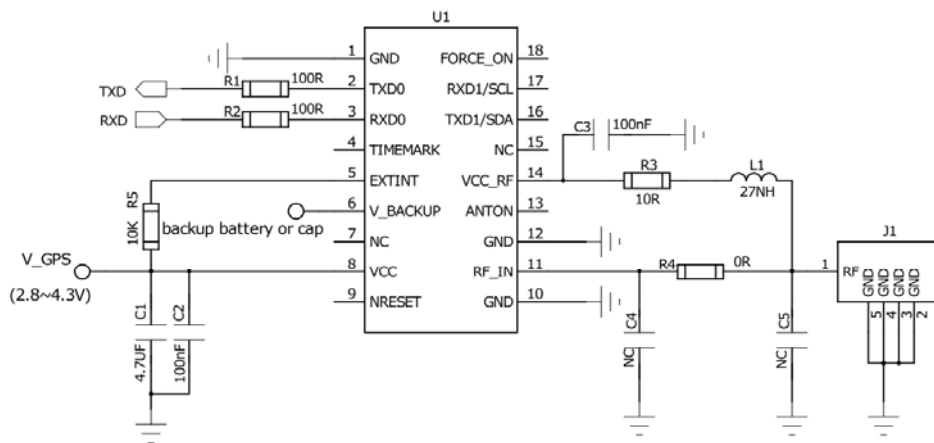

Figure 14: Application schematics

Appendix

A. Related Documents

Table 13: Related documents

SN	Document name	Remark
[1]	MT3333 Platform NMEA Message Specification	
[2]	EPO-II_Format_Protocol_Customer	EPO-II_Format and Protocol

B. Terms and Abbreviations

Table 14: Terms and abbreviations

Abbreviation	Description
A-GPS	Assisted Global Positioning System
CMOS	Complementary Metal Oxide Semiconductor
CEP	Circular Error Probable
DGPS	Difference Global Positioning System
EEPROM	Electrically Erasable Programmable Read Only Memory
EPO	Extended Prediction Orbit
ESD	Electrostatic Sensitive Devices
EASY	Embedded Assist System
EGNOS	European Geostationary Navigation Overlay Service
GPS	Global Positioning System
GAGAN	The GPS Aided Geo Augmented Navigation
I/O	Input/Output
IC	Integrated Circuit
Inorm	Normal Current
Imax	Maximum Load Current
kbps	Kilo bits per second
MSL	moisture sensitive level
MSAS	Multi-Functional Satellite Augmentation System
NMEA	National Marine Electronics Association
PRN	Pseudo Random Noise Code
QZSS	Quasi-Zenith Satellites System
SBAS	Satellite Based Augmentation Systems
WAAS	Wide Area Augmentation System

Contact us:**Shanghai SIMCom Wireless Solutions Ltd.**

Add: SIM Technology Building, No.633, Jinzhong Road, Changning District, Shanghai P.R. China
200335

Tel: +86 21 3235 3300

Fax: +86 21 3235 3301

URL: www.sim.com/wm

SIMCOM CONFIDENTIAL FILE