



SIM68D

Hardware Design

GNSS Module

SIMCom Wireless Solutions Limited.

Building B, SIM Technology Building, No.633, Jinzhong Road

Changning District, Shanghai P.R.China

Tel: 86-21-31575100

support@simcom.com

www.simcom.com

Document Title:	SIM68D Hardware Design
Version:	1.03
Data	2020-09-23
Status:	Released

GENERAL NOTES

SIMCOM OFFERS THIS INFORMATION AS A SERVICE TO ITS CUSTOMERS TO SUPPORT THE APPLICATION AND ENGINEERING EFFORTS THAT USE THE PRODUCTS DESIGNED BY SIMCOM. THE INFORMATION PROVIDED IS BASED ON THE REQUIREMENTS SPECIFICALLY FROM THE CUSTOMERS. SIMCOM HAS NOT UNDERTAKEN ANY INDEPENDENT SEARCH FOR ADDITIONAL RELEVANT INFORMATION, INCLUDING ANY INFORMATION THAT MAY BE IN THE CUSTOMER'S POSSESSION. FURTHERMORE, THE SYSTEM VALIDATION OF THE PRODUCT DESIGNED BY SIMCOM WITHIN A LARGER ELECTRONIC SYSTEM REMAINS THE RESPONSIBILITY OF THE CUSTOMER OR THE CUSTOMER'S SYSTEM INTEGRATOR. ALL SPECIFICATIONS SUPPLIED HEREIN ARE SUBJECT TO CHANGE WITHOUT NOTICE.

COPYRIGHT

THIS DOCUMENT CONTAINS THE PROPRIETARY TECHNICAL INFORMATION WHICH IS THE PROPERTY OF SIMCOM LIMITED, COPYING OF THIS DOCUMENT, GIVING IT TO OTHERS, THE USING OR COMMUNICATION OF THE CONTENTS THEREOF ARE FORBIDDEN WITHOUT THE OFFICIAL AUTHORITY BY SIMCOM. OFFENDERS ARE LIABLE TO THE PAYMENT OF THE DAMAGES. ALL RIGHTS ARE RESERVED IN THE EVENT OF GRANT OF A PATENT OR THE REGISTRATION OF A UTILITY MODEL OR DESIGN. ALL SPECIFICATIONS SUPPLIED HEREIN ARE SUBJECT TO CHANGE WITHOUT NOTICE.

SIMCom Wireless Solutions

Building B, SIM Technology Building, No.633 Jinzhong Road, Changning District, Shanghai P.R.China

Tel: +86 21 31575100

Email: simcom@simcom.com

For more information, please visit:

<https://www.simcom.com/download/list-863-en.html>

For technical support, or to report documentation errors, please visit:

<https://www.simcom.com/ask/> Or email to: support@simcom.com

Copyright © SIMCom Wireless Solutions Limited 2020

Version History

Date	Version	Description of change	Author
2020-06-17	V1.01	Origin	Zhang Shuai Wang Jia
2020-08-19	V1.02	Update test data	Zhang Shuai Ye Hai Bing
2020-09-23	V1.03	Update radio frequency description, reference document, SLEEP mode	Zhang Shuai Wang Jia

SIMCom
Confidential

Contents

1	Introduction.....	8
1.1	SIM68D Functional Diagram.....	9
1.1.1	GNSS Performance.....	10
1.1.2	General features.....	12
2	Package Information.....	13
2.1	Pin out Diagram.....	13
2.1.1	Pin Description.....	13
2.2	Package Dimensions.....	16
2.3	SIM68D Recommended PCB Decal.....	17
3	Application Interface.....	18
3.1	Power Management.....	18
3.1.1	Power Input.....	18
3.1.2	Starting SIM68D.....	18
3.1.3	Verification of SIM68D Start.....	18
3.1.4	Power Saving Modes.....	18
3.1.5	Operating Mode.....	19
3.2	VCC_RF.....	20
3.3	UART Interface.....	20
3.4	SPI Interface.....	21
3.5	I2C Interface.....	21
3.6	Timemark Output.....	21
3.7	A-GPS.....	22
3.7.1	EPO.....	22
3.7.2	EASY Mode.....	23
3.7.3	SBAS and RTCM.....	23
3.8	Antenna.....	24
3.8.1	Antenna Interface.....	24
3.8.2	Antenna Choice Consideration.....	25
3.8.2.1	4.8.2.1 Passive Antenna.....	25
3.8.2.2	4.8.2.2 Active Antenna.....	27
4	Electrical Characteristics.....	29
4.1	Absolute Maximum Ratings.....	29
4.2	Recommended Operating Conditions.....	29
4.3	Electro-Static Discharge.....	30
5	Manufacturing.....	31
5.1	Top and bottom View of SIM68D.....	31
5.2	Label information.....	32
5.3	Assembly and Soldering.....	32
5.4	Moisture sensitivity.....	33
5.5	ESD handling precautions.....	34
5.6	Shipment.....	35

6	Reference Design	36
7	Appendix	38
7.1	Related Documents.....	38
7.2	Terms and Abbreviations.....	38

SIMCom
Confidential

Table Index

TABLE 1: GNSS PERFORMANCE.....	10
TABLE 2: GENERAL FEATURES.....	12
TABLE 3: PIN DESCRIPTION.....	14
TABLE 4: POWER SUPPLY AND CLOCK STATE ACCORDING TO OPERATION MODE.....	19
TABLE 5: HOST PORT MULTIPLEXED FUNCTION PINS.....	20
TABLE 6 : SPI FUNCTION PINS.....	21
TABLE 7: GNSS OPERATING FREQUENCIES.....	25
TABLE 8: ANTENNA SPECIFICATIONS.....	25
TABLE 9: ABSOLUTE MAXIMUM RATINGS.....	29
TABLE 10: SIM68D OPERATING CONDITIONS.....	29
TABLE 11: SIM68D STANDARD IO FEATURES.....	29
TABLE 12: THE ESD CHARACTERISTICS (TEMPERATURE: 25°C, HUMIDITY: 45 %).....	30
TABLE 13: ILLUSTRATION OF MODULE INFORMATION.....	32
TABLE 14: MOISTURE CLASSIFICATION LEVEL AND FLOOR LIFE.....	33
TABLE 14: RELATED DOCUMENTS.....	38
TABLE 15: TERMS AND ABBREVIATIONS.....	38

Figure Index

FIGURE 1: SIM68D FUNCTIONAL DIAGRAM.....	9
FIGURE 2: SIM68D PIN OUT DIAGRAM (TOP VIEW).....	13
FIGURE 3: SIM68D MECHANICAL DIMENSIONS (UNIT: MM).....	16
FIGURE 4: RECOMMENDED PCB DECAL (TOP VIEW) (UNIT: MM).....	17
FIGURE 5: TIMEMARK APPLICATION CIRCUIT.....	22
FIGURE 6: SIM68D PASSIVE ANTENNA DESIGN.....	26
FIGURE 7: SIM68D PASSIVE ANTENNA DESIGN (WITH EXTERNAL LNA AND SAW).....	26
FIGURE 8: SIM68D PASSIVE ANTENNA DESIGN FOR BEST PERFORMANCE AND INCREASED IMMUNITY.....	27
FIGURE 9: SIM68D ACTIVE ANTENNA DESIGN.....	28
FIGURE 10: TOP AND BOTTOM VIEW OF SIM68D.....	31
FIGURE 11: LABEL OF SIM68D.....	32
FIGURE 12: THE RAMP-SOAK-SPIKE REFLOW PROFILE OF SIM68D.....	33
FIGURE 13: EXAMPLE APPLICATION SCHEMATIC.....	36

SIMCom
Confidential

1 Introduction

This document describes the hardware interface of the SIMCom module SIM68D, SIM68D is a GNSS All-in-one solution, which can be used as a Stand-alone or A-GPS (Assisted Global Positioning System), GLONASS and QZSS receiver. All functional components of SIM68D are described in great detail, and SIM68D supports L1+L5.

SIM68D is a GNSS All-in-one module with stand-alone GPS (A-GPS supported) /GLONASS/BEIDOU receiver, with built-in LNA, SIM68D can relax antenna requirement and don't need external LNA. SIM68D supports various location and navigation applications, including autonomous GPS, GLONASS, BEIDOU, SBAS ranging (WAAS, EGNOS, GAGAN and MSAS), QZSS, DGPS (RTCM), and A-GPS.

Key Features

The module provides complete signal processing from antenna input to host port in NMEA messages. The module requires 2.8V to 4.3V power supply, which gives customers plenty of choices for the application circuit. The host port is configurable to UART. Host data and I/O signal levels are 2.8V CMOS compatible.

- GPS/GLONASS/BEIDOU receiver, supports multi-GNSS include QZSS, DGPS (RTCM), SBAS ranging, supports WAAS/EGNOS/MSAS/GAGAN
- 33tracking/99 acquisition-channel GNSS receiver
- Small footprint: 16 x 12.2 x 2.4mm, 24-pin LCC package
- 12 multi-tone active interference cancellers and jamming elimination⁽¹⁾
- Indoor and outdoor multi-path detection and compensation
- Max fixed update rate up to 10 HZ⁽²⁾
- Advanced software features
 1. Alwayslocate advanced location awareness technology
 2. EPO/HotStill orbit prediction
 3. EASY self-generated orbit prediction
- Pulse-per-second (PPS) GPS time reference
 1. Adjustable duty cycle
 2. typical accuracy: $\pm 10\text{ns}$
- Interface
 1. UART
 2. SPI
 3. I2C
 4. UART1⁽³⁾
- Operating temperature: -40 ~ +85°C
- Accuracy **1.5m** CEP
- RoHS compliant

NOTE

- (1) AIC is default open and can be controlled by PMTK command, see *document [2]* for details.
- (2) Default is 1 HZ.
- (3) RTCM function.

1.1 SIM68D Functional Diagram

The following figure shows a functional diagram of the SIM68D and illustrates the mainly functional parts:

- The main chip
- SAW filter
- Low noise amplifier
- The antenna interface
- The communication interface
- The control signals

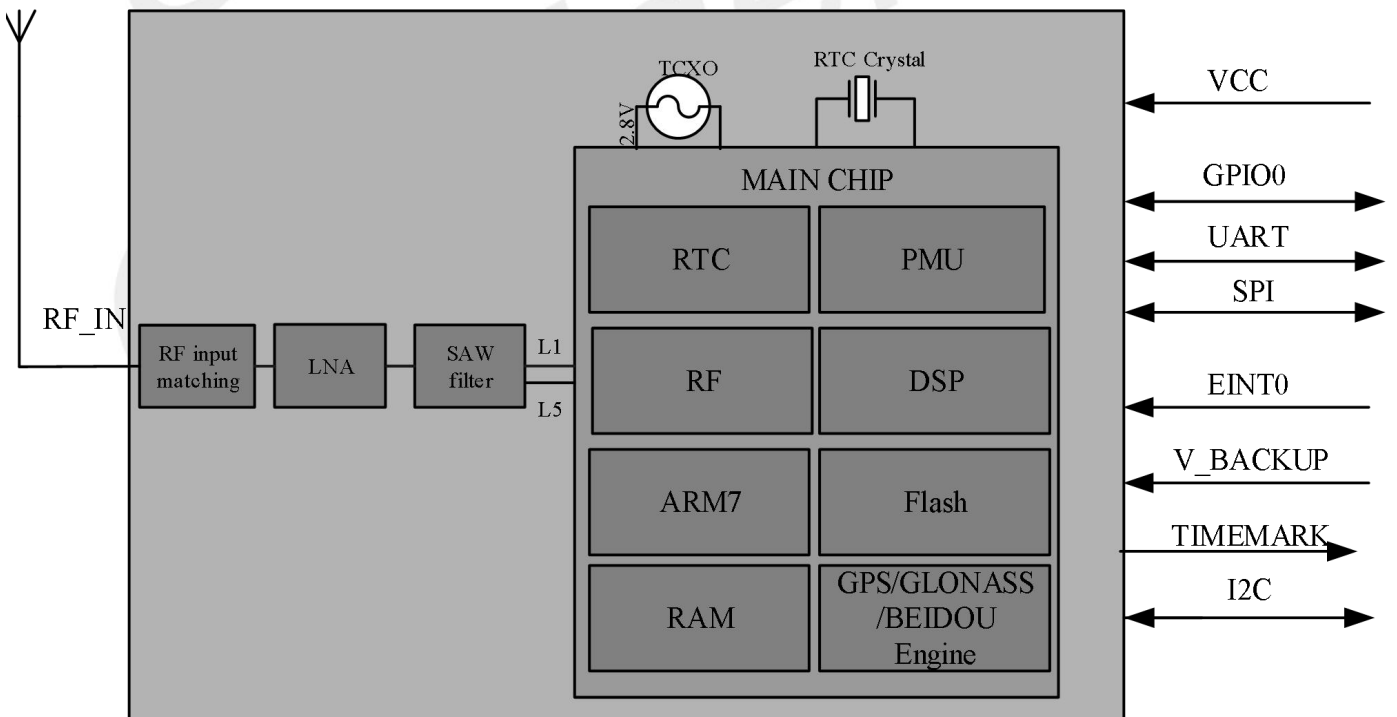

Figure 1: SIM68D functional diagram

1.1.1 GNSS Performance

Table 1: GNSS Performance

Parameter	Description	Performance			Unit
		Min	Type	Max	
Horizontal Position Accuracy ⁽¹⁾	Automatic position		<1.5		m
Velocity Accuracy ⁽²⁾	Without Aid		0.1		m/s
Acceleration Accuracy	DGPS		0.05		m/s
Timing Accuracy	Without Aid		TBD		m/s ²
	DGPS		TBD		m/s ²
			10		nS
Dynamic Performance	Maximum Altitude			18000	m
	Maximum Velocity			500	m/s
	Maximum Acceleration			4	G
TTFF with GPS (L1) and GLONASS ⁽³⁾	Hot start		0.62		S
	Warm start		24.28		S
	Cold start		27.02		S
TTFF with GPS (L1) only ⁽³⁾	Hot start		0.65		S
	Warm start		24.5		S
	Cold start		26.98		S
TTFF with GPS (L1+L5) only ⁽³⁾	Hot start		0.56		S
	Warm start		24.6		S
	Cold start		26.71		S
TTFF with GPS (L1+L5) and GALILEO ⁽³⁾	Hot start		0.60		S
	Warm start		24.84		S
	Cold start		30.74		S
A-GPS	Hot start		0.41		S
TTFF(EPO in flash mode)	Warm start		2.82		S
	Cold start		12.52		S
Sensitivity with GPS (L1) mode	Autonomous acquisition(cold start)		-148		dBm
	Re-acquisition		-160		dBm
	Tracking		-165		dBm

1.1.2 General features

Table 2: General features

Parameters	Value	
Supply voltage VCC	+2.8V~4.3V	
Supply voltage ripple VCC	54 mV(RMS) max @ f = 0~3MHz 15 mV(RMS) max @ f > 3 MHz	
Power consumption(acquisition)	31mA.@ VCC=3.3 V	
Power consumption(sleep)	340uA.@ VCC=3.3 V	
Storage temperature	-40°C~+85°C	
Operating temperature	-40°C~+85°C (note 1)	
2.8V I/O signal levels	V _{IL}	-0.3~0.7V
	V _{IH}	1.75~3.1V
	V _{OL}	-0.3~0.7V
	V _{OH}	1.75~3.1V
1.8V I/O signal levels	V _{IL}	-0.3~0.63V
	V _{IH}	1.17~2.1V
	V _{OL}	-0.3~0.63V
	V _{OH}	1.17~2.1V
I/O output sink/source capability	+/- 3mA max	
I/O input leakage	+/- 10 uA max	
Host port	UART	
Other port	I2C/SPI,UART1	
Serial port protocol (UART)	NMEA; 8 bits, no parity, 1 stop bit; 115200 baud (configurable)	
TM output (1PPS)	1 pulse per second, synchronized at rising edge, pulse length 300ms	

NOTE

Operation in the temperature range -40°C~ -30°C is allowed but Time-to-First-Fix performance and tracking sensitivity may be degraded.

2 Package Information

2.1 Pin out Diagram

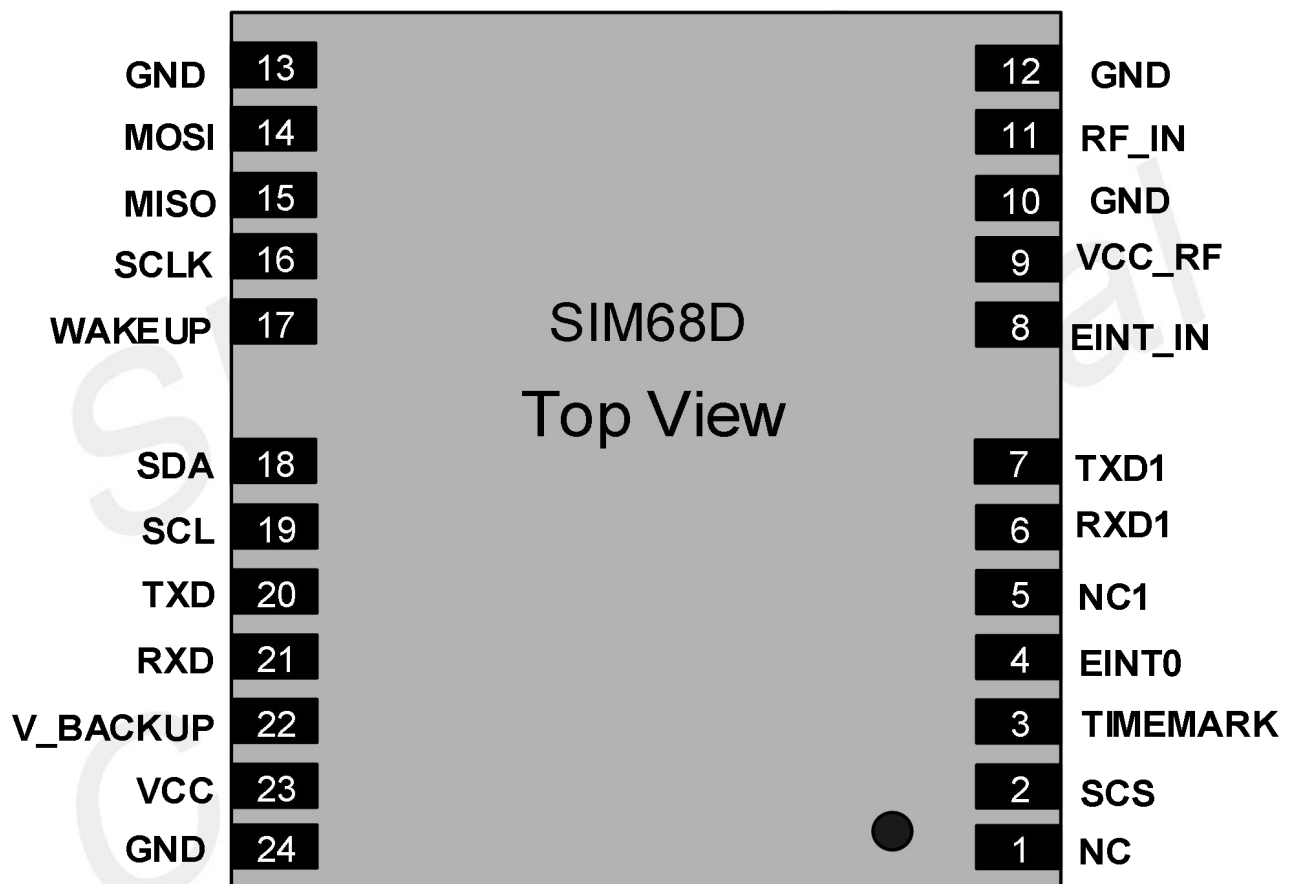

Figure 2: SIM68D pin out diagram (Top view)

2.1.1 Pin Description

Table 3: Pin description

Pin name	Pin number	I/O	Description	Comment
Power supply				
VCC	23	I	Main power input, which will be used to power the baseband and RF section internally.	Provide clean and stable power source to this pin. Add a 4.7uF capacitor to this pin for decoupling.
VCC_RF	9	O	2.8V output power supply for active antenna	If unused, keep open.
V_BACKUP	22	I/O	The backup battery input power supply for RTC	If unused, keep open.
GND	10,12,13,24		Ground	GND
Host port interface				
MISO	15	I	SPI MISO	
MOSI	14	O	SPI MOSI	1.8V power domain, If unused, keep open.
SCLK	16	O	SPI clock	
SCS	2	O	SPI slave select	
SDA	18	I/O	I2C data	1.8V power domain, If unused, keep open.
SCL	19	I/O	I2C Clock	
TXD	20	O	Serial output	2.8V power domain
RXD	21	I	Serial input	2.8V power domain
TXD1	7	O	RTCM function	2.8V power domain
RXD1	6	I		If unused, keep open.
GPIOs				
EINT0	4	I	This interrupt source could act as wake up event during power saving mode. Provide an interrupt on either high or low logic level or edge-sensitive interrupt	2.8V power domain, If unused, keep open.
TIMEMARK	3	O	Time Mark outputs timing pulse related to receiver time	2.8V power domain, If unused, keep open.
EINT_IN	8	I/O	The interrupt signal is also connected to System Power Management (SPM) as a wakeup source.	1.8V power domain, If unused, keep open.
WAKEUP	17	I/O	The interrupt signal is also connected to System Power Management (SPM) as a wakeup source.	1.8V power domain, If unused, keep open.
RF interface				
RF_IN	11	I	Radio antenna connection	Impedance must be controlled to 50Ω.
Other interface				

NC

1,5

Not Connected

Keep floating

SIMCom
Confidential

2.2 Package Dimensions

Following figure shows the Mechanical dimensions of SIM68D (top view, side view and bottom view).

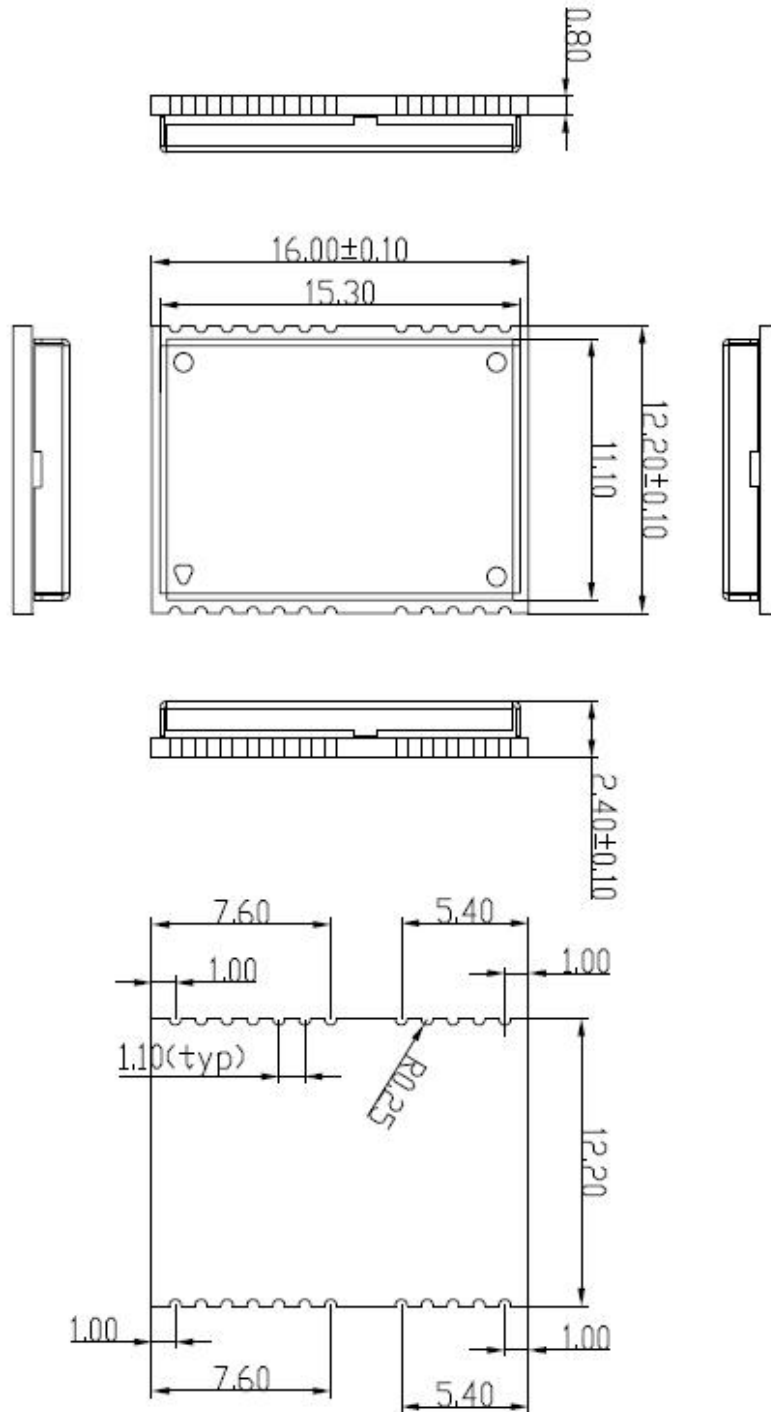

Figure 3: SIM68D mechanical dimensions (Unit: mm)

2.3 SIM68D Recommended PCB Decal

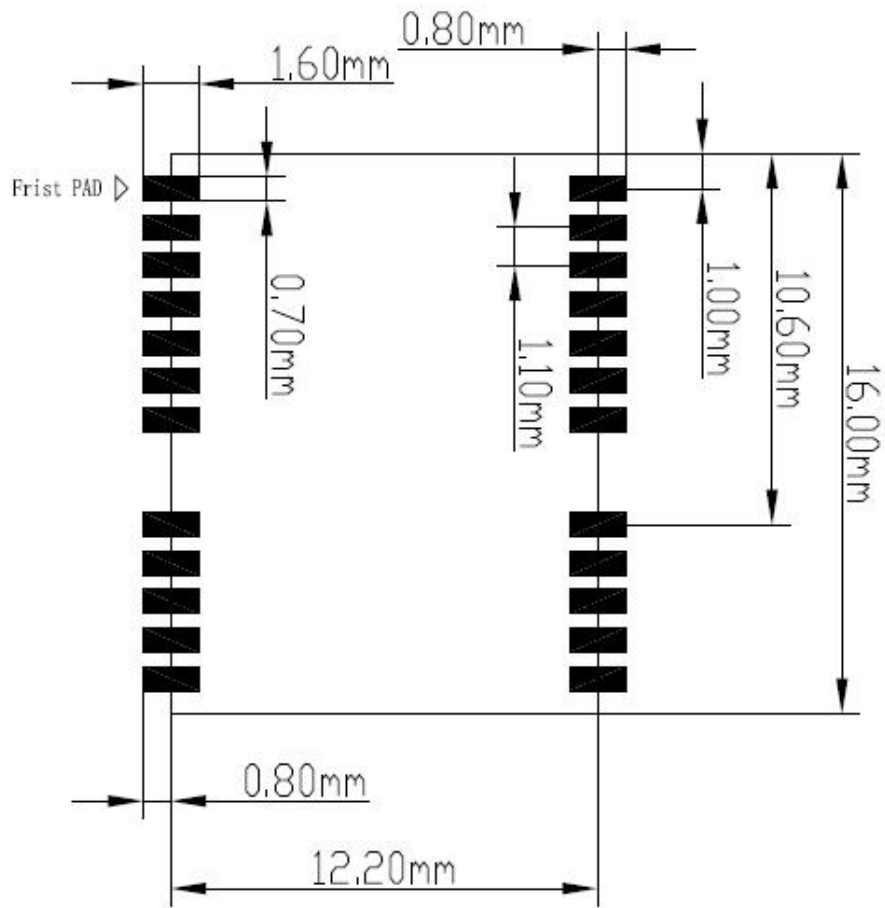

Figure 4: Recommended PCB decal (top view) (Unit: mm)

3 Application Interface

3.1 Power Management

3.1.1 Power Input

The power supply range of SIM68D is from 2.8V to 4.3V. The power supply should be able to provide sufficient current up to 100mA.

3.1.2 Starting SIM68D

For initial power up, the RTC must start oscillating to sequence the Finite State Machine. RTC start-up time may vary, when power is first applied, SIM68D goes into operation mode.

3.1.3 Verification of SIM68D Start

System activity indication depends upon the chosen serial interface:

When it is activated, SIM68D will output messages at the selected UART speed, and message types. The default baud rate is 115200bps.

NOTE

The baud rate information can be found on the label.

3.1.4 Power Saving Modes

SIM68D supports power saving modes for reducing average power consumption like sleep mode, backup mode, periodic mode, and AlwaysLocate™ mode.

- **Sleep mode:** In this mode the receiver stays at full on power state. This mode can be waken up by the host by sending the command through the communication interface or external interrupt.
- **Backup mode:** In this mode the SIM68D must be supplied by the backup battery and it can help to count down the time for backup mode. Software on host side to send the command through the communication interface to into the backup mode.
- **Periodic mode:** In this mode the SIM68D enters tracking and backup modes according to the interval configured by users in the commands.
- **AlwaysLocate™ mode:** AlwaysLocate™ is an intelligent controller of SIM68D periodic mode. Depending on the environment and motion conditions, SIM68D can adaptive adjust the on/off time to achieve balance of positioning accuracy and power consumption.

NOTE

The modes mentioned above are operated by PMTK commands, users can refer to “SIM68 Series_NMEA Message_User Guide” for more information.

SIM68D provides very low leakage battery backup memory, which contains all the necessary GNSS information for quick start up and a small amount of user configuration variables. It needs a 3V power supply for V_BACKUP pin, and the stable operation region ranges from very light load to about 3mA.

3.1.5 Operating Mode

Table 4: Power supply and clock state according to operation mode

Mode	VCC	V_BACKUP	Internal LDO	Main clock	RTC clock
Full on	on	on	on	on	on
Sleep	on	on	on	off	on
Backup	on	on	off	off	on

Full on Mode

The module will enter full on mode after first power up with factory configuration settings. Power consumption will vary depending on the amount of satellite acquisitions and number of satellites in track. This mode is also referenced as Full on, Full Power or Navigation mode.

Navigation is available and any configuration settings are valid as long as the VCC power supply is active. When the power supply is off, settings are reset to factory configuration and receiver performs a cold start on next power up.

Sleep Mode

Sleep mode means a low quiescent (340uA type.) power state, non-volatile RTC, and backup RAM block is powered on. Other internal blocks like digital baseband and RF are internally powered off. The power supply input VCC shall be kept active all the time, even during sleep mode.

Waking up from and entering into sleep mode is controlled by UART interface, Enter \$PAIR003*39\r\n to enter sleep mode, Enter \$PAIR002*38\r\n to enter sleep mode.

NOTE

You must enter \$PAIR002*38\r\n before starting sleep mode, otherwise it will affect the current consumption of sleep mode.

3.2 VCC_RF

VCC_RF is a 2.8V output for external antenna, for the detail usage of VCC_RF, customer can refer to document [3] for more information.

3.3 UART Interface

SIM68D includes two UART interfaces.

One UART interface for serial communication, and this UART support NMEA output and PMTK command input. UART can provide the developers signal or message outputs.

UART1 interface is the RTCM format data input used for RTCM function.

Table 5: Host port multiplexed function pins

Pin name	Pin number	UART function
TXD	20	data transmit
RXD	21	data receive

NOTE

The default baud rate is 9600 or 115200, if other baud rate required please contact SIMCom.

3.4 SPI Interface

The SPI interface is for connection of external serial flash to save configuration and A-GPS data. The SCS chip select signal is available to select external slaves. External SPI serial flash up to 128Mbits is supported.

Table 6 : SPI function pins

Pin name	Pin number	SPI function
MISO	15	Master input
MOSI	14	Master output
SCLK	16	Clock output
SCS	2	Chip select

3.5 I2C Interface

The SCL and SDA can be connected to an external I2C interface EEPROM up to 1 Mbits for reading and writing data into EEPROM. This can be used to store configurations permanently.

NOTE

The EEPROM and flash can't be supported synchronously

3.6 Timemark Output

The Timemark pin outputs pulse-per-second (1PPS) pulse signal for precise timing purposes after the position has been fixed. The Timemark signal can be provided through designated output pin for many external applications. This pulse is not only limited to be active every second but also allowed to set the required duration, frequency, and active high/low by programming user-defined settings.

The following figure is the typical application of the TIMEMARK function.

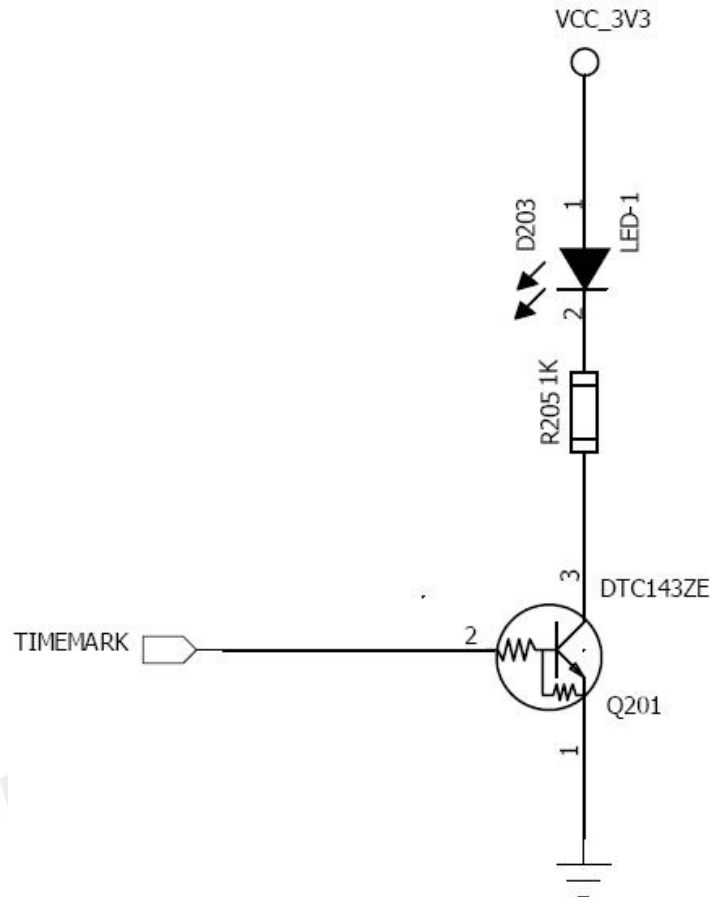

Figure 5: TIMEMARK application circuit

3.7A-GPS

A-GPS is the meaning of Assisted GPS, which is a system that can under certain conditions improve the startup performance, or time-to-first-fix (TTFF) of a GPS satellite-based positioning system. SIM68D module supports EPO file, EASY mode, SBAS and RTCM.

3.7.1 EPO

The SIM68D supports the EPO (Extended Prediction Orbit) data service. The EPO data service is supporting 7/14/30-day orbit predictions to customers. It needs occasional download from EPO server. Supply of aiding information like ephemeris, almanac, rough last position and time and satellite status and an optional time synchronization signal will reduce time to first fix significantly.

The user should update the EPO files from the EPO server in the period of validity of EPO file through the internet. Then the EPO data should send to the SIM68D by the HOST side. SIM68D has the shorter cold TTFF and warm TTFF, when the A-GPS is used.

NOTE

For more information about EPO, please contact SIMCom.

3.7.2 EASY Mode

EASY is the abbreviation of Embedded Assist System, it works as embedded software which accelerates TTFF by predicting satellite navigation messages from received ephemeris.

No additional computing interval for EASY task. EASY is efficiently scheduled and computed in free time of every second after GPS navigation solution.

Easy function is conceptually designed to automatically engage for predicting after first receiving the broadcast ephemeris. After a while (generally tens of seconds), 3-day extensions will be completely generated then all EASY functions will be maintained at a standby condition. EASY assistance is going to be engaged when the GPS requests in new TTFF condition or re-generates again with another new received ephemeris. Meanwhile, TTFF will be benefited by EASY assistance.

NOTE

EASY function is default open and can be closed by PMTK command.

3.7.3 SBAS and RTCM

SBAS is the abbreviation of Satellite Based Augmentation System. The SBAS concept is based on the transmission of differential corrections and integrity messages for navigation satellites that are within sight of a network of reference stations deployed across an entire continent. SBAS messages are broadcast via geostationary satellites able to cover vast areas.

Several countries have implemented their own satellite-based augmentation system. Europe has the European Geostationary Navigation Overlay Service (EGNOS) which covers Western Europe and beyond. The USA has its Wide Area Augmentation System (WAAS). Japan is covered by its Multi-functional Satellite Augmentation System (MSAS). India has launched its own SBAS program named GPS and GEO Augmented Navigation (GAGAN) to cover the Indian subcontinent.

SIM68D module supports SBAS and RTCM, but only one mode can be applied at one time, and SBAS is

the default feature, customers who want to apply RTCM in the design can contact SIMCom for supporting.

3.8 Antenna

The antenna is the most critical item for successful GPS/GLONASS/BEIDOU reception in a weak signal environment. Proper choice and placement of the antenna will ensure that satellites at all elevations can be seen, and therefore, accurate fix measurements are obtained.

It is recommended to use an active GPS/GLONASS/BEIDOU antenna. In a typical application, SIM68D with an active antenna can get a tracking sensitivity about 3dB better than SIM68D with a passive antenna.

3.8.1 Antenna Interface

The SIM68D receives L1 and L5 band signals from GPS/GLONASS/BEIDOU satellites, The RF signal is connected to the RF_IN pin. And the trace from RF_IN to antenna should be controlled to 50Ω impedance.

To suit the physical design of individual applications the RF interface pad can lead to two alternatives:

- Recommended approach: solderable RF coaxial cable assembly antenna connector, such as HRS' U.FL-R-SMT (10) connector or I-PEX's 20279-001E-01 RF connector.
- SMA connector.

3.8.2 Antenna Choice Consideration

To obtain excellent GNSS reception performance, a good antenna will always be required. Proper choice and placement of the antenna will ensure that satellites at all elevations can be seen, and therefore, accurate fix measurements are obtained.

The following table shows GNSS Operating frequencies

Table 7: GNSS Operating frequencies

Type	Frequency
GPS L1	1575.42±1.023MHz
GLONASS G1	1601.7±6.75MHz
Galileo E1	1575.42±1.023MHz
BeiDou B1I	1561.098±2.046MHz
GPS L5	1176.45±10.23MHz
BeiDou B2a	1176.45±10.23MHz
Galileo E5a	1176.45±10.23MHz

The suggested active antenna should be chosen as following:

Table 8: Antenna Specifications

	Specification	Passive and active antenna
Active Antenna Recommendations	Frequency range L1	1560~1609MHz
	Frequency range L5	1166~1187MHz
	Polarization	RHCP
	Gain	>20dB (max 50 dB)
	Noise Figure	<1.5 dB

3.8.2.14.8.2.1 Passive Antenna

Passive antenna contains only the radiating element, e.g. the ceramic patch, the helix structure, and chip antennas. Sometimes it also contains a passive matching network to match the electrical connection to 50 Ohms impedance.

The most common antenna type for GPS/GLONASS/BEIDOU application is the patch antenna. Patch antennas are flat, generally have a ceramic and metal body and are mounted on a metal base plate.

Figure 6 shows a minimal setup for a GPS/GLONASS/BEIDOU receiver with SIM68D module.

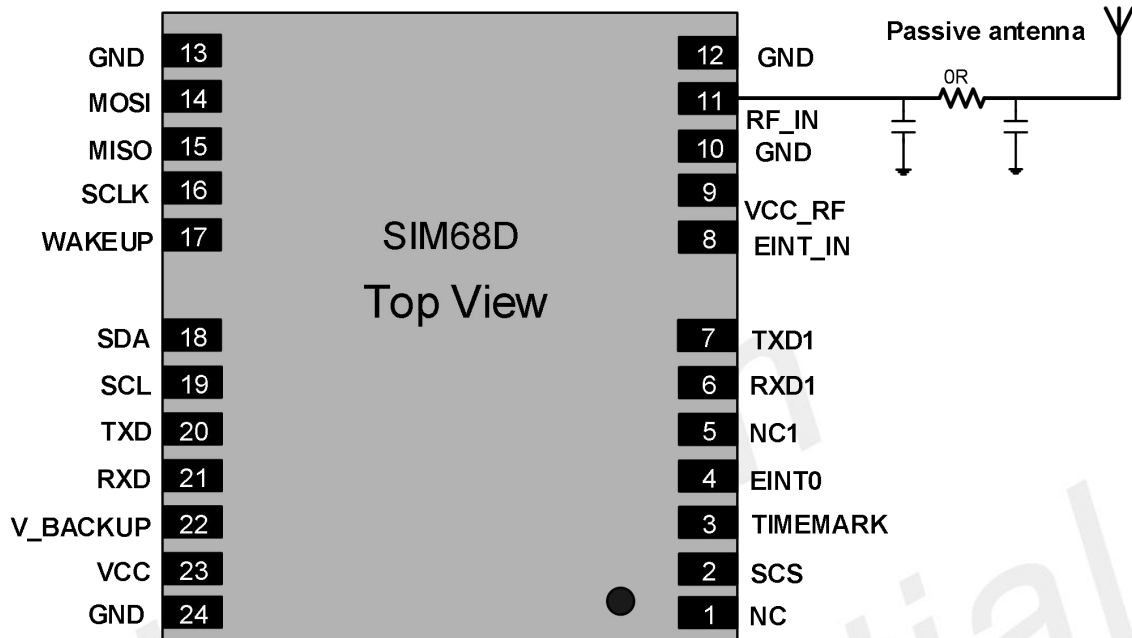

Figure 6: SIM68D passive antenna design

For better performance with passive antenna designs user can use an external LNA to increase the sensitivity up 3~4 dB. Please see Figure 7.

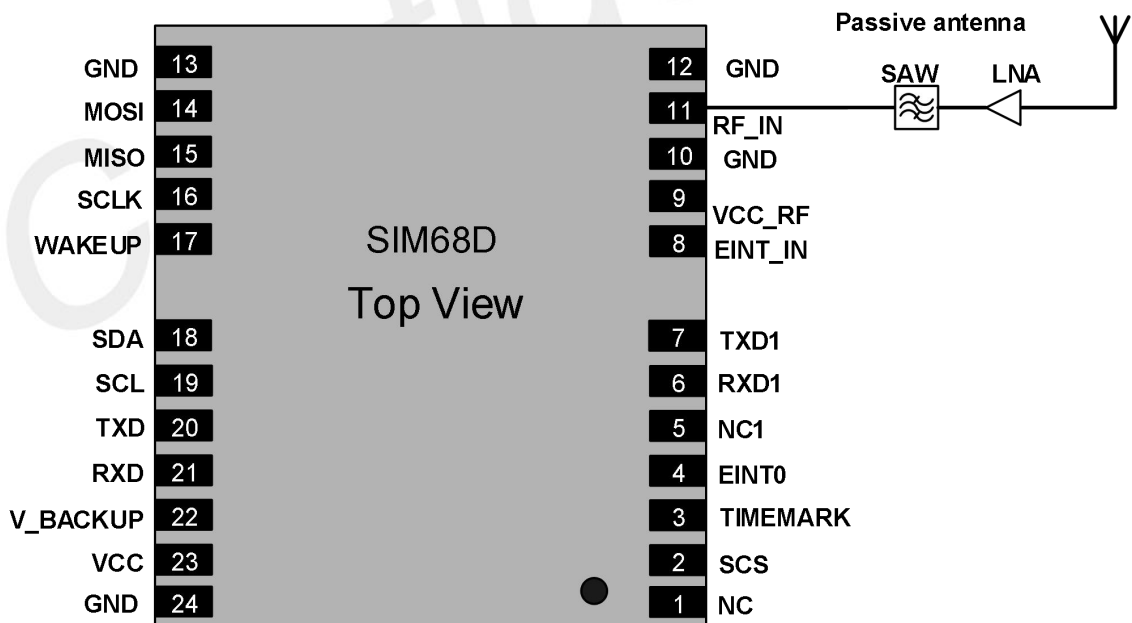

Figure 7: SIM68D passive antenna design (with external LNA and SAW)

For best performance, user can add an external saw based on Figure7 design to avoid interference, please see Figure 8.

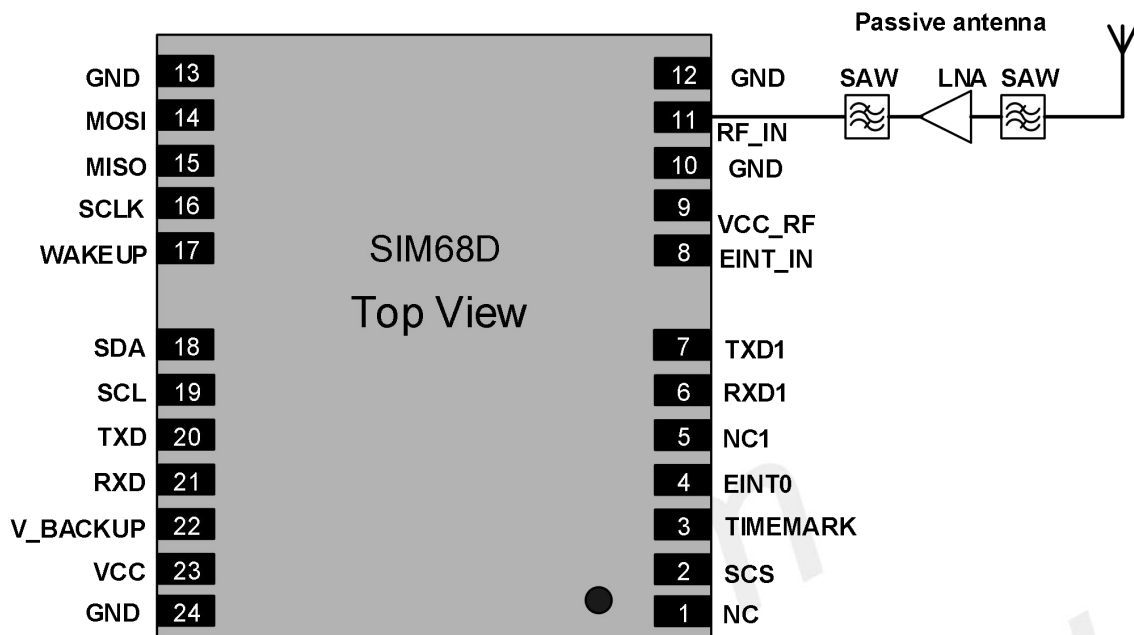

Figure 8: SIM68D passive antenna design for best performance and increased immunity

3.8.2.24.8.2.2 Active Antenna

Active antenna has an integrated Low-Noise Amplifier (LNA). Active antenna needs a power supply that will contribute to GNSS system power consumption.

Usually, the supply voltage is fed to the antenna through the coaxial RF cable shown as Figure 9. The output voltage of PIN 9 is 2.8V. If the supply voltage of active antenna is 2.8V, PIN 9 VCC_RF can be connected to RF_IN as figure 9 shows. If the active antenna is not 2.8V, other power should be connected to RF_IN.

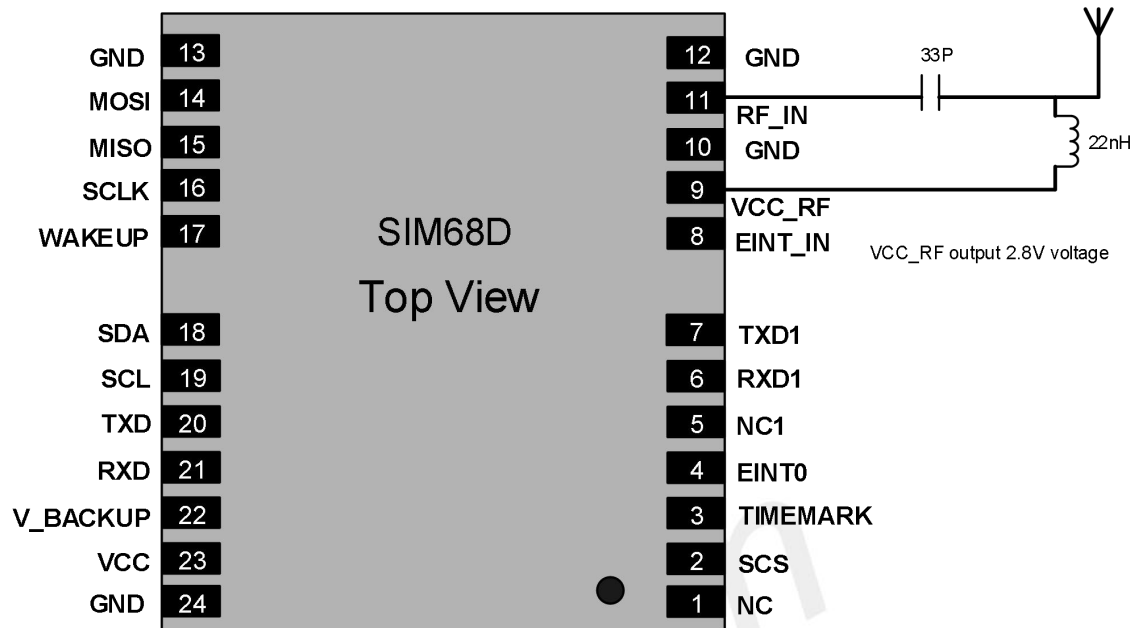

Figure 9: SIM68D active antenna design

If the customer's design is for automotive applications, then an active antenna can be used and located on top of the car in order to guarantee the best signal quality.

GNSS antenna choice should base on the designing product and other conditions. For detailed Antenna designing consideration, please refer to related antenna vendor's design recommendation. The antenna vendor will offer further technical support and tune their antenna characteristic to achieve successful GNSS reception performance depending on the customer's design.

4 Electrical Characteristics

4.1 Absolute Maximum Ratings

The absolute maximum ratings stated in Table 8 are stress ratings under non-operating conditions. Stresses beyond any of these limits will cause permanent damage to SIM68D.

Table 9: Absolute maximum ratings

Parameter	Min	Max	Unit
VCC	-	4.3	V
RF_IN	-	3.6	V
V_BACKUP	-	4.6	V
I/O pin voltage	-	2.8	V
Storage temperature	-50	+125	°C
Operating Temperature	-40	+85	°C

NOTE

The absolute maximum rating of RF_IN please reference to the active antenna datasheet

4.2 Recommended Operating Conditions

Table 10: SIM68D operating conditions

Parameter	Symbol	Min	Typ	Max	Unit
Operating temperature range		-40	+25	+85	°C
Main supply voltage	VCC	2.8	3.3	4.3	V
Active antenna supply voltage output	VCC_RF	2.7	2.8	2.9	V
	I _{max}			10	mA
Backup battery voltage	V_BACKUP	2.3		4.6	V

Table 11: SIM68D standard IO features

Parameter	Symbol	Min	Typ	Max	Unit
Low level output voltage Test conditions IOL = 2mA and 4.0mA@2.8V	V _{ol}	-0.3		0.7	V
High level output voltage Test conditions IOL = 2mA and 4.0mA@2.8V	V _{oh}	1.75		3.1	V
Low level input voltage@2.8V	V _{il}	-0.3		0.7	V
High level input voltage@2.8V	V _{ih}	1.75		3.1	V
Low level output voltage Test conditions IOL = 2mA and 4.0mA@1.8V	V _{ol}	-0.3		0.63	V
High level output voltage Test conditions IOL = 2mA and 4.0mA@1.8V	V _{oh}	1.17		2.1	V
Low level input voltage@1.8V	V _{il}	-0.3		0.63	V
High level input voltage@1.8V	V _{ih}	1.17		2.1	V
Input Pull-up resistance	RPU	40		190	K Ω
Input Pull-down resistance	RPD	40		190	K Ω
Input capacitance	C _{in}		5		pF
Load capacitance	C _{load}			8	pF
Tri-state leakage current	IOZ	-10		10	μ A

4.3 Electro-Static Discharge

The GPS engine is not protected against Electrostatic Discharge (ESD) in general. Therefore, it is subject to ESD handling precautions that typically apply to ESD sensitive components. Proper ESD handling and packaging procedures must be applied throughout the processing, handling and operation of any application using a SIM68D module.

Table 12: The ESD characteristics (Temperature: 25°C, Humidity: 45 %)

Pin	Contact discharge (KV)	Air discharge (KV)
VCC	TBD	TBD
GND	TBD	TBD
VCC_RF	TBD	TBD
RF_IN	TBD	TBD

5 Manufacturing

5.1 Top and bottom View of SIM68D



Figure 10: Top and bottom view of SIM68D

NOTE

The above is the design effect diagram of the module for reference. The actual appearance is subject to the actual product.

5.2 Label information

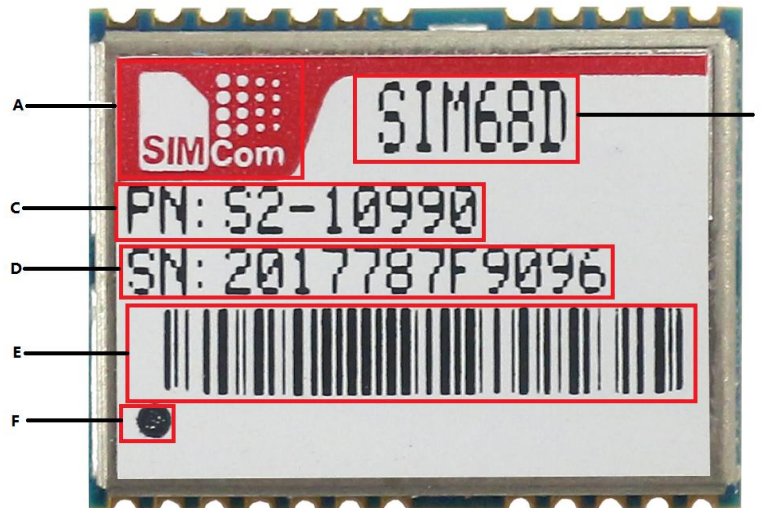

Figure 11: Label of SIM68D

Table 13: illustration of module information

Item	Description
A	Logo of SIMCom
B	Module name
C	Module part number Hardware number included; ex.S2-10990 is hardware number
D	Module serial number The first number stands for factory code; The second number stands for year code; The third to eighth numbers is the SN number in hexadecimal numeric; The last two numbers stands for MNEA sentence baud rate, “11” stands for 115200, “96” stands for 9600;
E	Module bar code Stands for the first 6 numbers of SN number
F	PIN 1 Mark

5.3 Assembly and Soldering

The SIM68D module is intended for SMT assembly and soldering in a Pb-free reflow process on the top

side of the PCB. Suggested solder paste stencil height is 150um minimum to ensure sufficient solder volume. If required paste mask pad openings can be increased to ensure proper soldering and solder wetting over pads.

The following figure is the Ramp-Soak-Spike Reflow Profile of SIM68D:

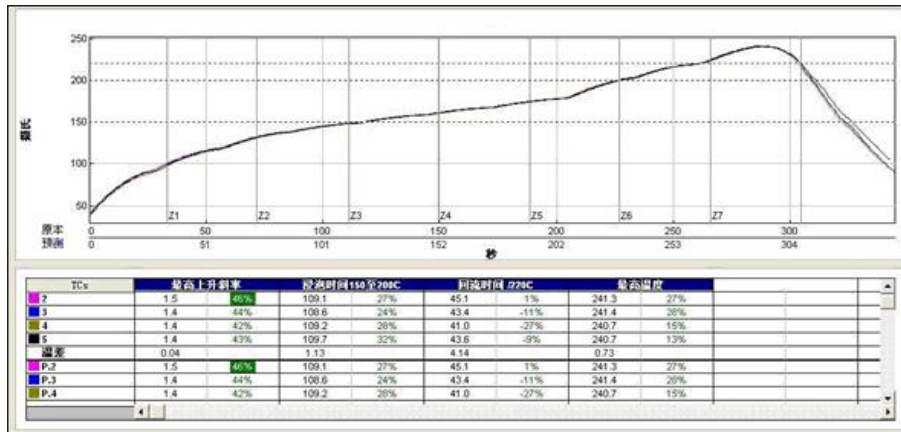

Figure 12: The Ramp-Soak-Spike reflow profile of SIM68D

SIM68D is Moisture Sensitive Devices (MSD), appropriate MSD handling instruction and precautions are summarized in Chapter 6.3.

SIM68D modules are also Electrostatic Sensitive Devices (ESD), handling SIM68D modules without proper ESD protection may destroy or damage them permanently.

Avoid ultrasonic exposure due to internal crystal and SAW components.

5.4 Moisture sensitivity

SIM68D module is moisture sensitive at MSL level 3, dry packed according to IPC/JEDEC specification J-STD-020C. The calculated shelf life for dry packed SMD packages is a minimum of 12 months from the bag seal date, when stored in a non condensing atmospheric environment of <40°C/90% RH.

Table 13 lists floor life for different MSL levels in the IPC/JDEC specification:

Table 14: Moisture Classification Level and Floor Life

Level	Floor Life(out of bag)at factory ambient $\leq +30^{\circ}\text{C}/60\%\text{RH}$ or as stated
1	Unlimited at $\leq +30^{\circ}\text{C}/85\%\text{RH}$
2	1 year
2a	4 weeks
3	168 hours
4	72 hours
5	48 hours
5a	24 hours

6

Mandatory bake before use. After bake, module must be reflowed within the time limit specified on the label.

Factory floor life is 1 week for MSL 3, SIM68D must be processed and soldered within the time. If this time is exceeded, or the humidity indicator card in the sealed package indicates that they have been exposed to moisture, the devices need to be pre-baked before the reflow solder process.

Both encapsulate and substrate materials absorb moisture. IPC/JEDEC specification J-STD-020 must be observed to prevent cracking and delamination associated with the "popcorn" effect during reflow soldering. The popcorn effect can be described as miniature explosions of evaporating moisture. Baking before processing is required in the following cases:

- Humidity indicator card: At least one circular indicator is no longer blue
- Floor life or environmental requirements after opening the seal have been exceeded, e.g. exposure to excessive seasonal humidity.

Refer to Section 4 of IPC/JEDEC J-STD-033 for recommended baking procedures.

NOTE

Oxidation Risk: Baking SMD packages may cause oxidation and/or inter metallic growth of the terminations, which if excessive can result in solder ability problems during board assembly. The temperature and time for baking SMD packages are therefore limited by solder ability considerations. The cumulative bake time at a temperature greater than 90°C and up to 125°C shall not exceed 96 hours.

5.5 ESD handling precautions

SIM68D modules are Electrostatic Sensitive Devices (ESD). Observe precautions for handling!



Failure to observe these precautions can result in severe damage to the GPS receiver!

GPS receivers are Electrostatic Sensitive Devices (ESD) and require special precautions when handling. Particular care must be exercised when handling patch antennas, due to the risk of electrostatic charges. In addition to standard ESD safety practices, the following measures should be taken into account whenever handling the receiver:

Unless there is a galvanic coupling between the local GND (i.e. the work Table) and the PCB GND, then the first point of contact when handling the PCB shall always be between the local GND and PCB GND. Before mounting an antenna patch, connect ground of the device

When handling the RF pin, do not come into contact with any charged capacitors and be careful when contacting materials that can develop charges (e.g. patch antenna ~10pF, coax cable ~50-80pF/m, soldering iron, ...)

To prevent electrostatic discharge through the RF input, do not touch the mounted patch antenna.

When soldering RF connectors and patch antennas to the receiver's RF pin, the user must make sure to use an ESD safe soldering iron (tip).

5.6 Shipment

SIM68D is designed and packaged to be processed in an automatic assembly line, and it is now packaged in SIM68D tray.

SIMCom
Confidential

6 Reference Design

Following figure is the typical application of SIM68D with active antenna which supplied by VCC_RF. If customer applies other kind of active antenna, keep PIN 9 floating and connect other voltage to the R8.

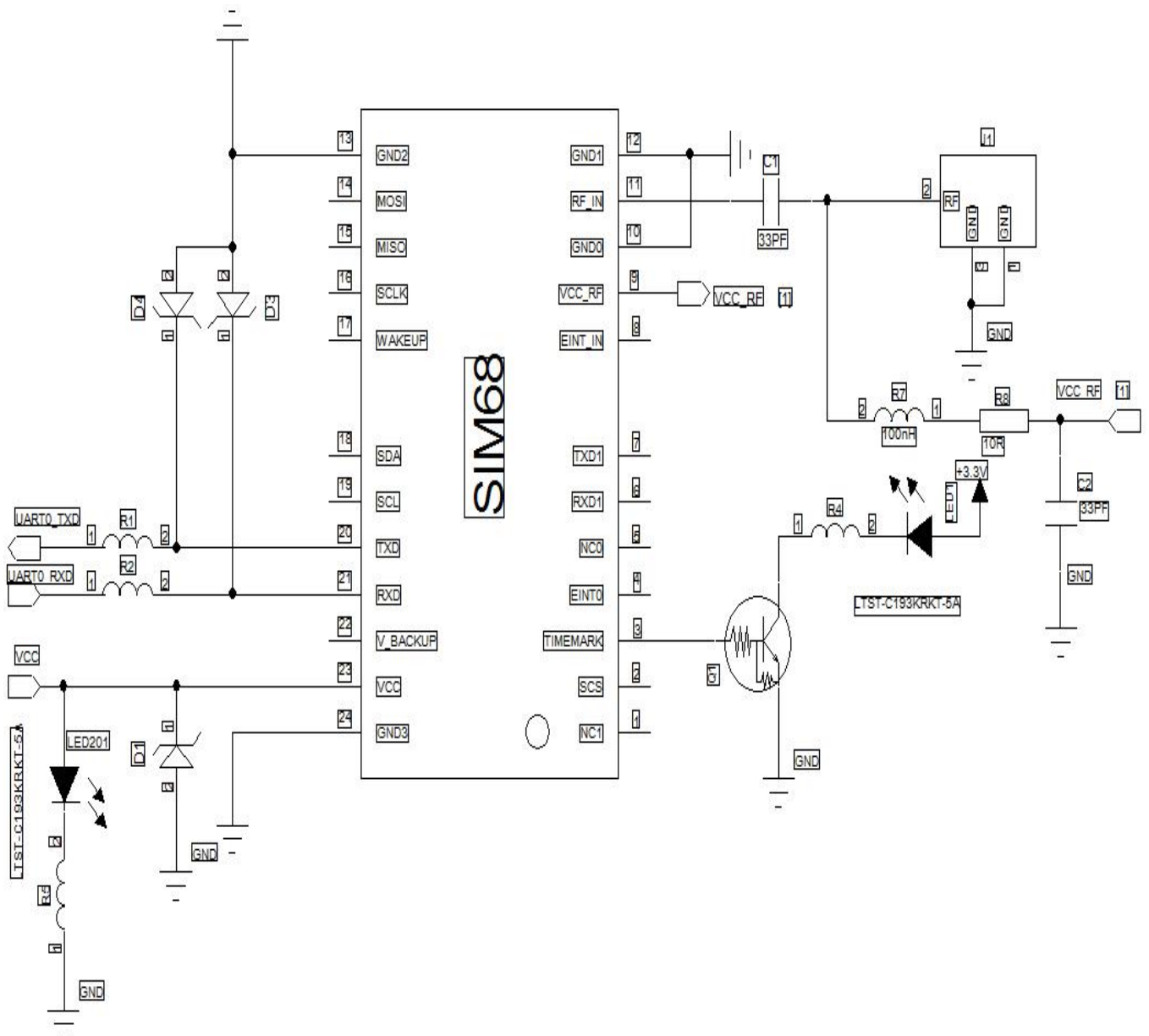

Figure 13: Example application schematic

I/Os of SIM6D are 2.8V and 1.8V CMOS voltage level; attentions should be paid if the voltage level of the host controller not compatible. V_BACKUP can use an un-rechargeable battery, if rechargeable battery used in the design, customer should design a charge circuit. Please contact SIMCom to get more support.

SIMCom
Confidential

7 Appendix

7.1 Related Documents

Table 14: Related documents

SN	Document name	Remark
[1]	SIM68D and SIM68I_EVB kit_User Guide	
[2]	SIM68 Series_NMEA Message_User Guide	
[3]	SIM68D REFERENCE DESIGN	

7.2 Terms and Abbreviations

Table 15: Terms and abbreviations

Abbreviation	Description
A-GPS	Assisted- Global Positioning System
CMOS	Complementary Metal Oxide Semiconductor
DGPS	Difference Global Positioning System
EASY	Embedded Assist System
EEPROM	Electrically Erasable Programmable Read Only Memory
EGNOS	Euro Geostationary Navigation Overlay Service
EPO	Extended Prediction Orbit
ESD	Electrostatic Sensitive Devices
FSM	Finite State Machine
GAGAN	The GPS Aided Geo Augmented Navigation
GPS	Global Positioning System
GNSS	Global Navigation Satellite System
I/O	Input/Output
IC	Integrated Circuit
Inorm	Normal Current
I _{max}	Maximum Load Current
kbps	Kilo bits per second
LNA	Low Noise Amplifier
MSAS	Multi-Functional Satellite Augmentation
MSL	moisture sensitive level

NMEA	National Marine Electronics Association
QZSS	Quasi-Zenith Satellites System
RTCM	Radio Technical Commission for Maritime Services
SBAS	Satellite Based Augmentation Systems
WAAS	Wide Area Augmentation System

SIMCom
Confidential