

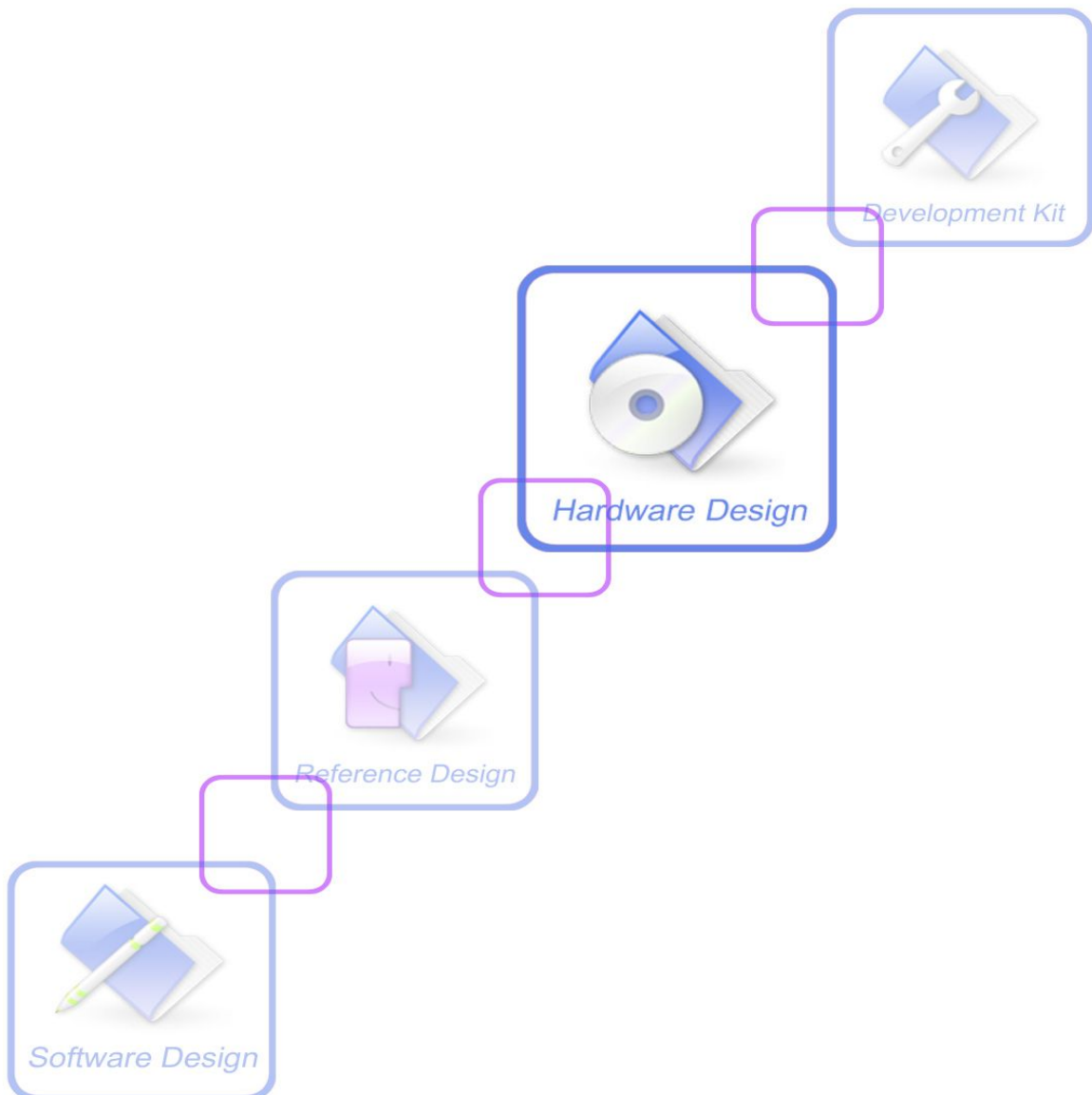

A company of SIM Tech

SIM5360-PCIEA_Hardware Design_V1.01



Document Title	SIM5360-PCIEA Hardware Design
Version	1.01
Date	2014-10-27
Status	Release
Document Control ID	SIM5360-PCIEA_Hardware_Design_V1.01

General Notes

SIMCom offers this information as a service to its customers, to support application and engineering efforts that use the products designed by SIMCom. The information provided is based upon requirements specifically provided to SIMCom by the customers. SIMCom has not undertaken any independent search for additional relevant information, including any information that may be in the customer's possession. Furthermore, system validation of this product designed by SIMCom within a larger electronic system remains the responsibility of the customer or the customer's system integrator. All specifications supplied herein are subject to change.

Copyright

This document contains proprietary technical information which is the property of SIMCom Limited, copying of this document and giving it to others and the using or communication of the contents thereof, are forbidden without express authority. Offenders are liable to the payment of damages. All rights reserved in the event of grant of a patent or the registration of a utility model or design. All specification supplied herein are subject to change without notice at any time.

Copyright © Shanghai SIMCom Wireless Solutions Ltd. 2014

Contents

Version History.....	6
1. Introduction.....	7
2. SIM5360-PCIEA Overview.....	8
2.1. SIM5360-PCIEA Key Features.....	9
2.2. Operating Mode.....	11
2.3. Functional Diagram.....	11
3. Package Information.....	13
3.1. Pin Out Diagram.....	13
3.2. PCI Express Mini Card Connector Pin Description.....	14
3.3. Package Dimensions.....	16
4. Application Interface.....	17
4.1. Power Supply.....	17
4.2. Power Saving Mode.....	17
4.2.1 Minimum Functionality Mode and Sleep Mode.....	17
4.2.2 Wake Up SIM5360-PCIEA from Sleep Mode.....	18
4.3. USB 2.0.....	18
4.3.1. USB Port Specification.....	18
4.3.2. Firmware Update.....	18
4.4. SIM Card Interface.....	18
4.5. PCM Interface.....	19
4.6. PERST#.....	20
4.7. W_DISABLE#.....	21
4.8. LED_WWAN#.....	21
4.9. WAKE#.....	22
4.10. UART Interface.....	23
4.11. Audio Interfaces.....	24
4.12. GNSS (GPS and GLONASS).....	26
4.13. RF Antenna Connector.....	26
5. Electrical, Reliability and Radio Characteristics.....	28
5.1. Absolute Maximum Ratings.....	28
5.2. Recommended Operating Conditions.....	28
5.3. SIM Card Interface Characteristics.....	28
5.4. USIM_VDD Characteristics.....	29
5.5. Current Consumption (VCC =3.3V+0.3V/-0.1V).....	29
5.6. Electro-Static Discharge.....	30
5.7. Radio Characteristics.....	31
5.7.1. Conducted Output Power.....	31
5.7.2. Conducted Receive Sensitivity.....	31
5.7.3. Supported Band.....	31
6. Appendix.....	33
I. SIM5360-PCIEA Top and Bottom View.....	33
II. Dimensions of SIM5360-PCIEA.....	34
III. Related Documents.....	36

IV.	Terms and Abbreviations.....	37
V.	Safety Caution.....	39

Table Index

TABLE 1:	SIM5360-PCIEA SERIES FREQUENCY BANDS.....	8
TABLE 2:	SIM5360-PCIEA KEY FEATURES.....	9
TABLE 3:	CODING SCHEMES AND MAXIMUM NET DATA RATES OVER AIR INTERFACE.....	10
TABLE 4:	OPERATING MODE.....	11
TABLE 5:	PCI EXPRESS MINI CARD CONNECTOR PIN DESCRIPTION.....	14
TABLE 6:	RECOMMENDED 3.3V POWER SUPPLY CHARACTERISTICS.....	17
TABLE 7:	THE CURRENT CONSUMPTION OF MINIMUM FUNCTIONALITY MODE (BS-PA-MFRMS=5).....	17
TABLE 8:	USB PORT SPECIFICATION.....	18
TABLE 9:	PCM SPECIFICATION.....	19
TABLE 10:	PCM DC CHARACTERISTICS.....	20
TABLE 11:	PERST# ELECTRICAL CHARACTERISTIC.....	20
TABLE 12:	FLIGHT MODE CONTROL FUNCTION.....	21
TABLE 13:	W_DISABLE# ELECTRICAL CHARACTERISTIC.....	21
TABLE 14:	NETWORK STATUS INDICATION PIN STATUS.....	21
TABLE 15:	UART ELECTRICAL CHARACTERISTIC.....	23
TABLE 16:	MIC INPUT CHARACTERISTICS.....	24
TABLE 17:	AUDIO OUTPUT CHARACTERISTICS.....	24
TABLE 18:	AUDIO PARAMETER.....	25
TABLE 19:	RECOMMENDED PASSIVE ANTENNA CHARACTERISTICS.....	26
TABLE 20:	RECOMMENDED ACTIVE ANTENNA CHARACTERISTICS.....	27
TABLE 21:	ABSOLUTE MAXIMUM RATINGS.....	28
TABLE 22:	OPERATING CONDITIONS.....	28
TABLE 23:	SIM CARD INTERFACE CHARACTERISTICS.....	28
TABLE 24:	USIM_VDD CHARACTERISTICS.....	29
TABLE 25:	CURRENT CONSUMPTION.....	29
TABLE 26:	ESD CHARACTERISTICS (TEMPERATURE: 25°C, HUMIDITY: 45 %).....	30
TABLE 27:	CONDUCTED OUTPUT POWER.....	31
TABLE 28:	CONDUCTED RECEIVE SENSITIVITY.....	31
TABLE 29:	SUPPORTED BAND.....	32
TABLE 30:	RELATED DOCUMENTS.....	36
TABLE 31:	TERMS AND ABBREVIATIONS.....	37
TABLE 32:	SAFETY CAUTION.....	39

Figure Index

FIGURE 1: SIM5360-PCIEA FUNCTIONAL DIAGRAM.....	12
FIGURE 2: SIM5360-PCIEA PIN OUT DIAGRAM.....	13
FIGURE 3: DIMENSIONS OF SIM5360-PCIEA(UNIT: MM))	16
FIGURE 4: SIM CARD HOLDER REFERENCE CIRCUIT.....	19
FIGURE 5: RESET TIMING.....	20
FIGURE 6: LED_WWAN# REFERENCE CIRCUIT.....	21
FIGURE 7: WAKE# BEHAVIOUR.....	22
FIGURE 8: WAKE# BEHAVIOR AS A CALLER.....	22
FIGURE 9: WAKE# REFERENCE CIRCUIT.....	22
FIGURE 10: UART1 FULL MODEM.....	23
FIGURE 11: NULL MODEM.....	23
FIGURE 12: REFERENCE CIRCUIT OF LEVEL SHIFT.....	24
FIGURE 13: RECEIVER INTERFACE CONFIGURATION.....	25
FIGURE 14: MICROPHONE INTERFACE CONFIGURATION.....	25
FIGURE 15: SIM5360-PCIEA TOP AND BOTTOM VIEW.....	33
FIGURE 16: DIMENSIONS OF SIM5360-PCIEA (UNIT: MM TOP VIEW).....	34
FIGURE 17: DIMENSIONS OF SIM5360-PCIEA (UNIT: MM BOTTOM AND SIDE VIEW).....	35

SIMCOM CONFIDENTIAL FILE

Version History

Date	Version	Description of change	Author
2014-10-27	1.01	Origin	Libing

SIMCOM CONFIDENTIAL FILE

1. Introduction

SIM5360-PCIEA module is PCI Express Mini Card. This document describes SIM5360-PCIEA hardware interface in great detail, which can help user to quickly understand SIM5360-PCIEA interface specifications, electrical and mechanical details.

SIMCOM CONFIDENTIAL FILE

2. SIM5360-PCIEA Overview

SIM5360-PCIEA series support quad-band GSM/GPRS/EDGE and dual-band UMTS/HSDPA/HSUPA/HSPA+, which work on frequencies GSM850,EGSM900,DCS1800,PCS1900,WCDMA2100/900 or WCDMA1900/WCDMA850 or WCDMA2100/ WCDMA850

The modules can be chosen based on the wireless network configuration. In this document, the entire radio band configuration of SIM5360-PCIEA series is described in the following table.

Table 1: SIM5360-PCIEA Series Frequency Bands

Standard	Frequency	SIM5360E-PCIEA	SIM5360A-PCIEA	SIM5360J-PCIEA
GSM	GSM 850MHz	✓	✓	✓
	EGSM 900MHz	✓	✓	✓
	DCS1800MHz	✓	✓	✓
	PCS1900MHz	✓	✓	✓
WCDMA	WCDMA 850MHz		✓	✓
	WCDMA 900MHz	✓		
	WCDMA 1900MHz		✓	
	WCDMA 2100MHz	✓		✓
HSPA	HSDPA	✓	✓	✓
	HSUPA	✓	✓	✓
DRX	Receiver Diversity	✓	✓	✓

SIM5360-PCIEA provides various hardware interfaces via Mini PCI Express card connector.

- **Power supply: : 3.3V+0.3/-0.1V**
- **USB Interface**
- **Audio Interface**
- **UART Interface**
- **SIM Interface**
- **PCM Interface**
- **W_DISABLE#**
- **WAKE#**
- **PERST#**
- **LED_WWAN#**

2.1. SIM5360-PCIEA Key Features

Table 2: SIM5360-PCIEA Key Features

Feature	Implementation
Power supply	Single supply voltage 3.3V+0.3V/-0.1V
Transmission data	<ul style="list-style-type: none"> ● Dual-mode UMTS/HSPA+/EDGE/GPRS operation ● GPRS Class B, multislot class 12 operation, Supports coding scheme: CS1-4 ● EDGE multislot class 12 operation, Supports coding schemes MSC1-9 ● UMTS R99 data rates-384 kbps DL/UL ● Category 6 HSDPA -14.4 Mbps HSUPA-5.76 Mbps ● CSD feature: 9.6, 14.4, 64 kbps UL/DL
SMS	<ul style="list-style-type: none"> ● MT, MO, CB, Text and PDU mode ● SMS storage: SIM card or ME(default) ● Support transmission of SMS alternatively over CSD or GPRS. User can choose preferred mode.
SIM interface	Support identity card: 1.8V, 3V.
USB	Support USB2.0 Slave mode
Audio features(optional)	Speech codec modes: <ul style="list-style-type: none"> ● Half Rate (ETS 06.20) ● Full Rate (ETS 06.10) ● Enhanced Full Rate (ETS 06.50 / 06.60 / 06.80) ● AMR (WCDMA)
Serial interface	<ul style="list-style-type: none"> ● Serial Port standard or null modem mode on Serial Port Interface ● Serial Port can be used to control module by sending AT command
Rx-diversity	Support UMTS Rx-diversity.
Phonebook management	Support phonebook types: SM, FD, LD, RC, ON, MC.
SIM application toolkit	Support SAT class 3, GSM 11.14 Release 98 Support USAT
Physical characteristics	Size: 50.95*32*4.95mm Weight:7 g
Firmware upgrade	Firmware upgrade over USB interface
PCM	Multiplex on GPIOs. Used for analog audio function with external codec. Support long frame sync and short frame sync. Support 8-bit A-law, μ -law and 16-bit linear data formats. Support master and slave mode, but must be the master in long frame sync.
Temperature range	<ul style="list-style-type: none"> ● Normal operation temperature: -30°C to +80°C ● Extended operation temperature: -40°C to +85°C ● Storage temperature -45°C to +90°C

Table 3: Coding schemes and maximum net data rates over air interface

Multislot definition(GRPS/EDGE)			
Slot class	DL slot number	UL slot number	Active slot number
1	1	1	2
2	2	1	3
3	2	2	3
4	3	1	4
5	2	2	4
6	3	2	4
7	3	3	4
8	4	1	5
9	3	2	5
10	4	2	5
11	4	3	5
12	4	4	5
GPRS coding scheme	Max data rata (4 slots)		Modulation type
CS 1 = 9.05 kb/s / time slot	36.2 kb/s		GMSK
CS 2 = 13.4 kb/s / time slot	53.6 kb/s		GMSK
CS 3 = 15.6 kb/s / time slot	62.4 kb/s		GMSK
CS 4 = 21.4 kb/s / time slot	85.6 kb/s		GMSK
EDGE coding scheme	Max data rata (4 slots)		Modulation type
MCS 1 = 8.8 kb/s/ time slot	35.2 kb/s		GMSK
MCS 2 = 11.2 kb/s/ time slot	44.8 kb/s		GMSK
MCS 3 = 14.8 kb/s/ time slot	59.2 kb/s		GMSK
MCS 4 = 17.6 kb/s/ time slot	70.4 kb/s		GMSK
MCS 5 = 22.4 kb/s/ time slot	89.6 kb/s		8PSK
MCS 6 = 29.6 kb/s/ time slot	118.4 kb/s		8PSK
MCS 7 = 44.8 kb/s/ time slot	179.2 kb/s		8PSK
MCS 8 = 54.4 kb/s/ time slot	217.6 kb/s		8PSK
MCS 9 = 59.2 kb/s/ time slot	236.8 kb/s		8PSK
HSDPA device category	Max data rate (peak)		Modulation type
Category 1	1.2Mbps		16QAM,QPSK
Category 2	1.2Mbp		16QAM,QPSK
Category 3	1.8Mbps		16QAM,QPSK
Category 4	1.8Mbps		16QAM,QPSK
Category 5	3.6Mbps		16QAM,QPSK
Category 6	3.6Mbps		16QAM,QPSK
Category 7	7.2Mbps		16QAM,QPSK
Category 8	7.2Mbps		16QAM,QPSK
Category 9	10.2Mbps		16QAM,QPSK
Category 10	14.4Mbps		16QAM,QPSK

HSUPA device category	Max data rate (peak)	Modulation type
Category 1	0.96Mbps	QPSK
Category 2	1.92Mbps	QPSK
Category 3	1.92Mbps	QPSK
Category 4	3.84Mbps	QPSK
Category 5	3.84Mbps	QPSK
Category 6	5.76Mbps	QPSK

2.2. Operating Mode

The table below summarizes the various operating modes of SIM5360-PCIEA.

Table 4: Operating Mode

Mode	Function
Normal operation	GSM/GPRS/EDGE/WCDMA/HSPA+ SLEEP Module will automatically go into sleep mode if the conditions of sleep mode are enabling and there is no on air and no hardware interrupt (such as GPIO interrupt or data on serial port). In this case, the current consumption of module will reduce to the minimal level. In sleep mode, the module can still receive paging message and SMS.
	GSM/WCDMA IDLE Software is active. Module registered to the GSM/WCDMA network, and the module is ready to communicate.
	GSM/WCDMA TALK Connection between two subscribers is in progress. In this case, the power consumption depends on network settings such as DTX off/on, FR/EFR/HR, hopping sequences, antenna.
	GPRS/EDGE/HSPA+ STANDBY Module is ready for GPRS/EDGE/HSPA+ data transfer, but no data is currently sent or received. In this case, power consumption depends on network settings and GPRS/EDGE/HSPA+ configuration.
	GPRS/EDGE/HSPA+ DATA TRANSFER There is GPRS/EDGE/HSPA+ data transfer in progress. In this case, power consumption is related with network settings (e.g. power control level); uplink/downlink data rates and GPRS configuration (e.g. used multi-slot settings).
Minimum functionality mode	AT command “AT+CFUN” can be used to set the module to a minimum functionality mode without removing the power supply. In this mode, the RF part of the module will not work or the SIM card will not be accessible, or both RF part and SIM card will be closed, and the serial port is still accessible. The power consumption in this mode is lower than normal mode.

2.3. Functional Diagram

The following figure is SIM5360-PCIEA functional diagram.

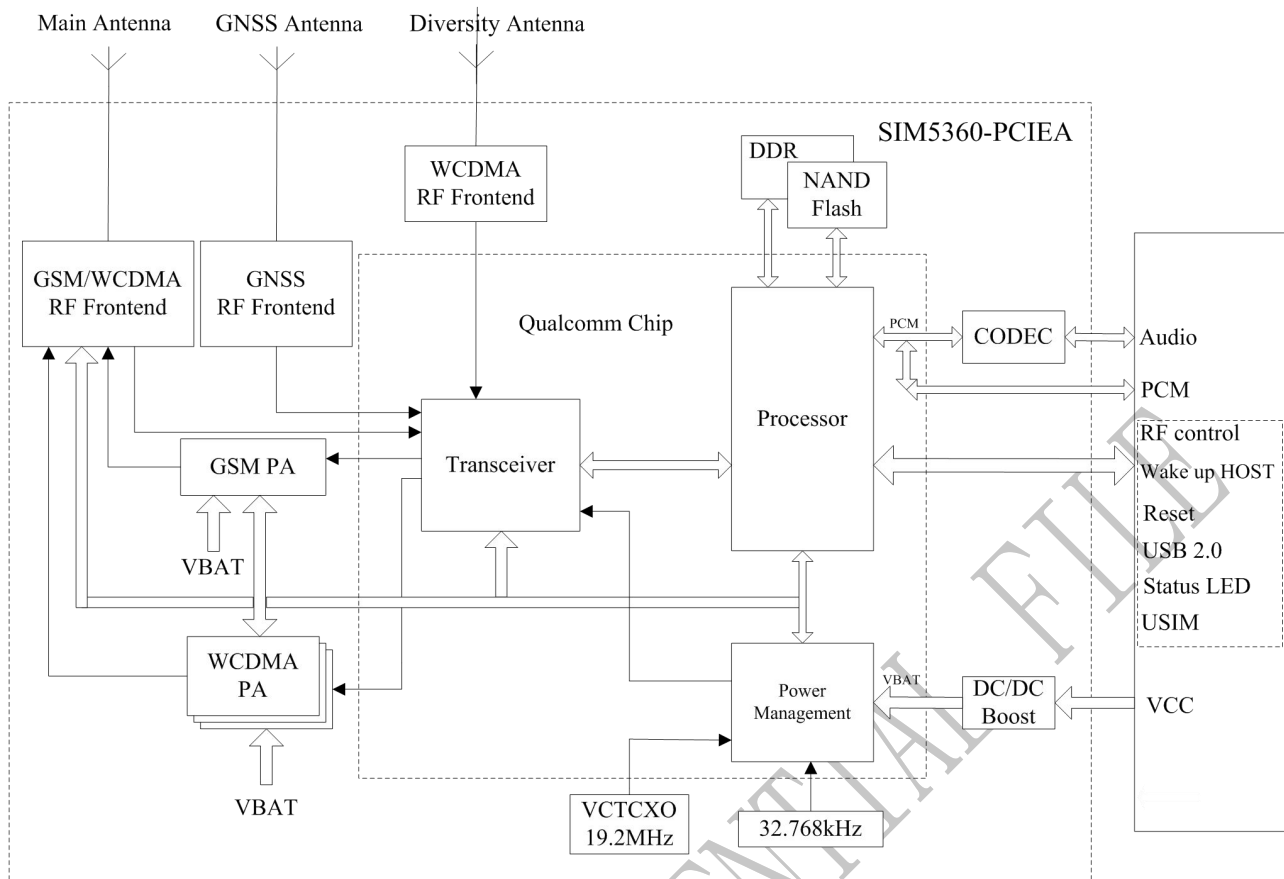

Figure 1: SIM5360-PCIEA Functional Diagram

SIMCOM CONFIDENTIAL

3. Package Information

3.1. Pin Out Diagram

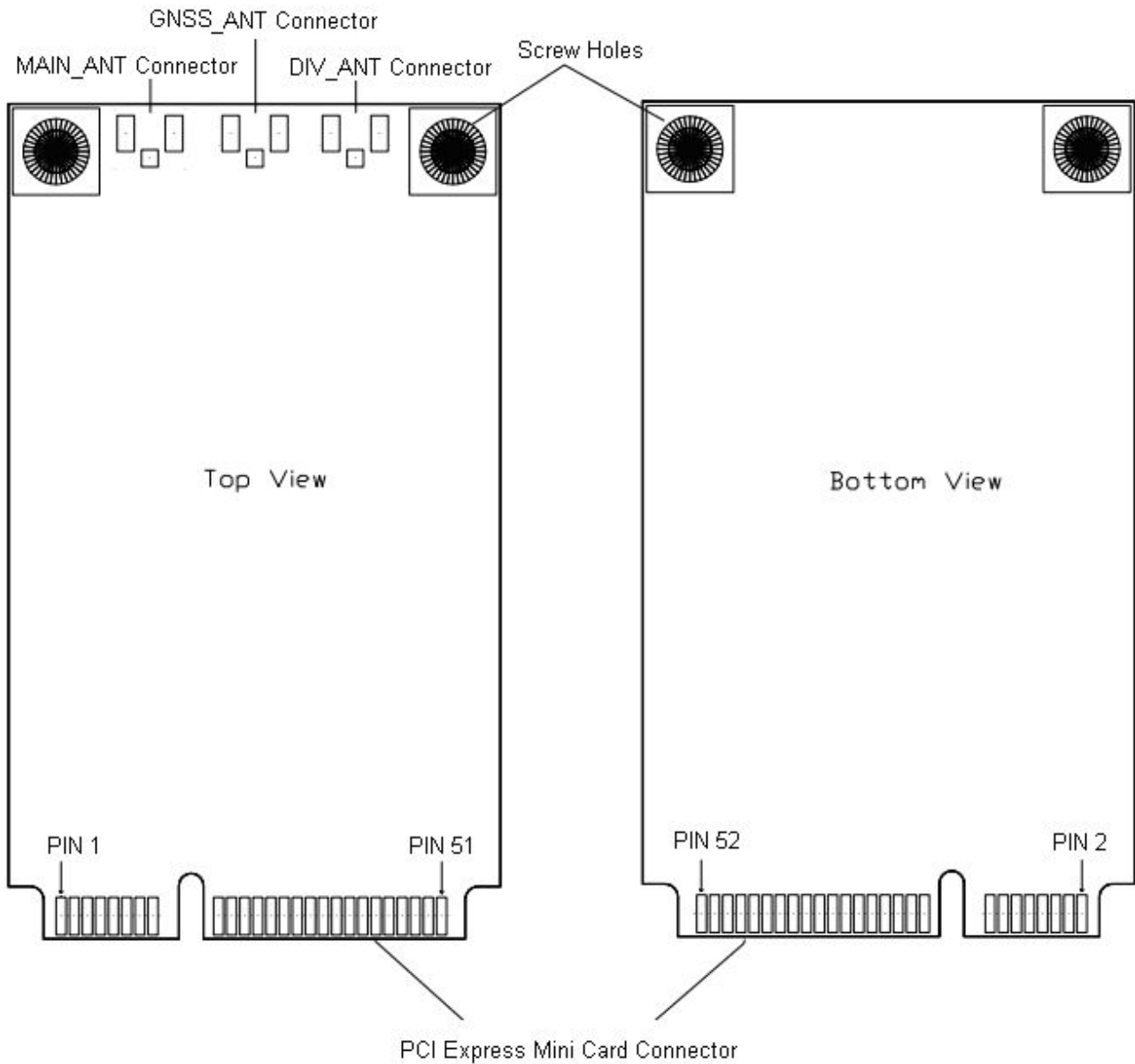

Figure 2: SIM5360-PCIEA Pin Out Diagram

3.2. PCI Express Mini Card Connector Pin Description

Table 5: PCI Express Mini Card Connector Pin Description

Pin name	Pin number	I/O	Description	Comment
Power supply				
VCC	2,24,39,41,52	I	3.3 Power supply for module	
GND	4,9,15,18,21, 26,27,29,34,3 5,37,40,43,50		Ground	
Reset				
PERST#	22	I	Reset input (Active low)	
USB 2.0				
USB_DP	38	I/O	USB 2.0 high speed port for data transfer, voice call, debug and FW download, etc.	
USB_DN	36			
SIM card interface				
USIM_VDD	8	O	1.8/3.0V Configurable LDO output, default 1.8V output, maximum output current is 30mA	
USIM_DATA	10	I/O	SIM data input/output	
USIM_CLK	12	O	SIM clock	
USIM_RST	14	O	SIM reset	
PCM interface				
PCM_CLK	45	O	PCM clock	If these pins are unused, keep open The PCM interface can not be used, if WM8960 CODEC chip is mounted on PCIE board.
PCM_OUT	47	O	PCM data output	
PCM_IN	49	I	PCM data input	
PCM_SYNC	51	O	PCM synchrony	
Audio interface				
MIC1P	1	I	Positive and negative voice-band input	If these pins are unused, keep open
MIC1N	3	I		
EAR1P	5	O	Positive and negative voice-band output, if not in use, left open	<i>If Analog audio is needed, please consult our sales staff, for more information .</i>
EAR1N	7	O		
UART interface				

UART_CTS	11	I	Clear to Send	If these pins are unused, keep open
UART_RTS	13	O	Request to send	
UART_RXD	17	I	Receive Data	
UART_TXD	19	O	Transmit Data	
UART_RI	44	O	Ring Indicator	
UART_DTR	46	I	DTE get ready	
GPIO interface				
GPIO9	30	I/O	General input/output PIN.	If these pins are unused, keep open
GPIO6	32	I/O	General input/output PIN.	
GPIO42	16	I/O	General input/output PIN.	
others				
WAKE#	1	O	Wake up host	<i>If Analog audio is available, wake up function is invalid Please consult our sales staff, for more information .</i>
W_DISABLE#	20	I	RF Control Input	
LED_WWAN#	42	O	Network Status Indication output	
NC	6,23,25,28,31,33,48	--	No connection	Keep open

SIMCOM.COM

3.3. Package Dimensions

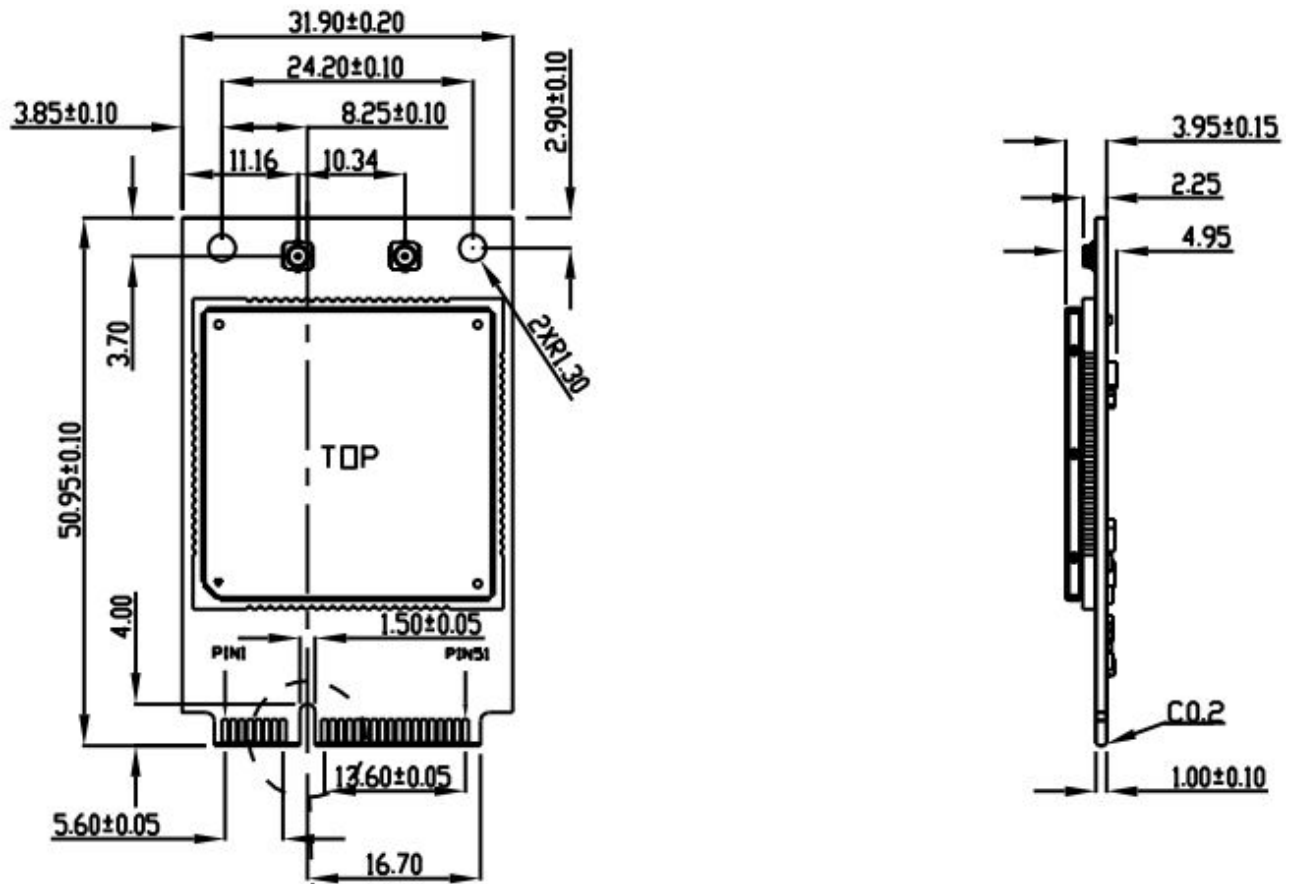

Figure 3: Dimensions of SIM5360-PCIEA(Unit: mm)

Please refer to appendix for package dimension details.

4. Application Interface

4.1. Power Supply

The recommended power supply voltage of SIM5360-PCIEA is 3.3V.

Table 6: Recommended 3.3V Power Supply Characteristics

Symbol	Parameter	Min	Type	Max	Unit
V _O	Power supply voltage	3.2	3.3	3.6	V
I _O	Supply current capability	2000	-	-	mA

4.2. Power Saving Mode

SIM5360-PCIEA has two power saving modes: minimum functionality mode and sleep mode. When SIM5360-PCIEA is in sleep mode and minimum functionality mode, the current of module is lowest.

4.2.1 Minimum Functionality Mode and Sleep Mode

The AT command “AT+CFUN=<fun>” can be used to set SIM5360-PCIEA into minimum functionality.

There are three functionality modes, which could be set by the AT command “AT+CFUN=<fun>”. The command provides the choice of the functionality levels <fun>=0, 1, 4.

- AT+CFUN=0: Minimum functionality.
- AT+CFUN=1: Full functionality (default).
- AT+CFUN=4: Flight mode (disable RF function).

Table 7: The Current Consumption of Minimum Functionality Mode (BS-PA-MFRMS=5)

<fun>	Current consumption(mA) (sleep mode)
0	1.4
1	1.6
4	1.4

Minimum functionality mode minimizes the current consumption to the lowest level. If SIM5360-PCIEA is set to minimum functionality by “AT+CFUN=0”, the RF function and SIM card function will be disabled. In this case, the serial port and USB port are still accessible, but all AT commands correlative with RF function and SIM card function will not be accessible.

Note: For detailed information about the AT Command “AT+CFUN=<fun>”, please refer to document [1].

If USB HOST sends USB suspend request, SIM5360-PCIEA will enter sleep mode automatically for reducing power consume, when peripheral equipment of SIM5360-PCIEA stops working, and module has no on air or audio activity required. In sleep mode, SIM5360-PCIEA can still receive paging or SMS from network.

Note: SIM5360-PCIEA could enter sleep mode when the host CPU supports USB suspend mode, otherwise it could not enter sleep mode.

4.2.2 Wake Up SIM5360-PCIEA from Sleep Mode

When SIM5360-PCIEA is in sleep mode, the following methods can wake up the module:

- USB HOST sends USB resume request.
- Receive a voice or data call from network.
- Receive a SMS from network.

4.3. USB 2.0

SIM5360-PCIEA is compliant with USB 2.0 specification. It supports full-speed and high-speed when acting as a peripheral device.

4.3.1. USB Port Specification

SIM5360-PCIEA could achieve data transfer, voice call, debug and software download, etc, through USB interface. When module is powered on, and connected USB_DP, USB_DN and GND to PC, and driver installed successfully, then 5 COM port, “*SIMTECH HS-USB Modem 9000*”, “*SIMTECH HS-USB NMEA 9000*”, “*SIMTECH HS-USB AT port 9000*”, “*SIMTECH HS-USB Diagnostics 9000*” and “*SIMTECH Wireless HS-USB Ethernet Adapter 9000*” could be recognized by the USB HOST.

Table 8: USB port Specification

Port Name	Description
SIMTECH HS-USB AT port 9000	Module could be controlled by sending AT command via USB Application Port.
SIMTECH HS-USB Diagnostics 9000	Module could be debugged by grabbing log through USB Debug Port.
SIMTECH HS-USB NMEA 9000	GPS data could be achieved through SIMTECH NMEA Device port. SIM5360-PCIEA has not this function.
SIMTECH HS-USB Modem 9000	Module could transfer data through Modem.
SIMTECH Wireless HS-USB Ethernet Adapter 9000	/

4.3.2. Firmware Update

If users need to upgrade through USB port, it is necessary to power on SIM5360-PCIEA first, then connect USB_DP, USB_DN, GND to USB HOST.

4.4. SIM Card Interface

The SIM interface complies with the GSM Phase 1 specification and the new GSM Phase 2+ specification for FAST 64 kbps SIM card. Both 1.8V and 3.0V SIM card are supported. The SIM interface is powered from an internal regulator in the module.

It is recommended to use an ESD protection component such as ST (www.st.com) ESDA6V1W5. Note that the SIM peripheral circuit should be close to the SIM card socket. The reference circuit of the 6-pin SIM card holder is illustrated in the following figure.

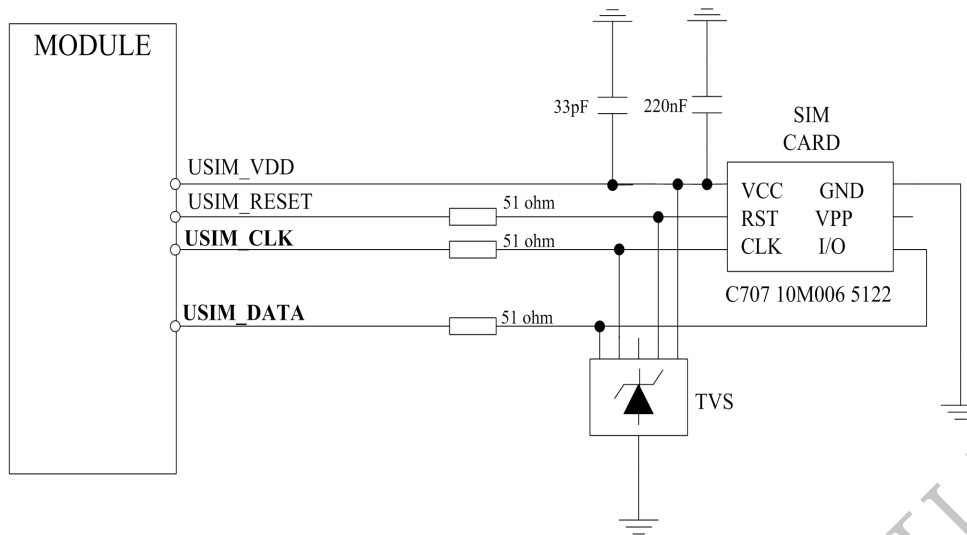

Figure 4: SIM Card Holder Reference Circuit

SIM card circuit is susceptible to be interfered, causing the SIM card failure or some other issues, so it is strongly recommended to follow these guidelines while designing:

- Make sure that SIM card holder should stay away from GSM antenna while in PCB layout;
- SIM traces should keep away from RF lines, VBAT and high-speed signal lines, and the shorter the better;
- Keep good connectivity between SIM holder GND and module GND;
- It is recommended to do some protection on USIM_CLK to keep away from interference;
- Recommended to place a 1uF capacitor on USIM_VDD line and keep close to the holder;
- Place some TVS, the parasitic capacitance should not exceed 50pF, and cascade 51Ohm resistor to enhance ESD protection.

4.5. PCM Interface

SIM5360-PCIEA provides hardware PCM interface for external codec. The PCM interface enables communication with an external codec to support hands-free applications. SIM5360-PCIEA PCM interface can be used in two modes: the default mode is auxiliary PCM (8 KHz short sync mode at 2048 KHz PCM CLK); the other mode is primary PCM (8 KHz long sync mode at 128 KHz PCM CLK). In short-sync (primary PCM) mode, SIM5360-PCIEA can be a master or a slave. In long-sync (auxiliary PCM) mode, SIM5360-PCIEA is always a master. SIM5360-PCIEA also supports 3 kinds of coding formats: 8 bits (u-law or A-law) and 16 bits (linear).

Note: The PCM interface can not be used, if WM8960 CODEC chip is mounted on PCIE board.

Table 9: PCM Specification

Characteristics	Specification
Line Interface Format	Linear or 8 bits (u-law or A-law)
Data length	16bits or 8 bits
PCM Clock/Sync Source	Master or a slave Mode(2048 KHz) / Master Mode(128 KHz)
PCM Clock Rate	2048 KHz / 128Khz
PCM Sync Format	Short sync/Long sync both support

Note: PCM interface can be control by AT command. For more details please refer to document [1] and document [2]

Table 10: PCM DC Characteristics

Symbol	Parameter	Min	Type	Max	Unit
V _{IH}	High-level input voltage	1.26	1.8	2.1	V
V _{IL}	Low-level input voltage	-0.3	0	0.63	V
V _{OH}	High-level output voltage	1.35	1.8	1.8	V
V _{OL}	Low-level output voltage	0	0	0.45	V

4.6. PERST#

The PERST# pin could be used as an emergency reset. SIM5360-PCIEA has power-up reset function, so power-up reset pulse is not necessary. When the PERST# pin is pulled to ground, the module will be reset. The PERST# pin is already pulled up in module, so the external pull-up resistor is not necessary.

The following table is the electrical characteristics of The PERST# pin.

Table 11: PERST# Electrical Characteristic

Symbol	Parameter	Min	Type	Max	Unit
V _{IH}	High-level input voltage	1.7	1.8	3.6	V
V _{IL}	Low-level input voltage	-	-	0.3	V
T _{high-hold}	After power up AND-NOT operation time(keep high level or keep open)	250	-	-	ms
T _{low-hold}	Reset low level hold on time	300	-	-	us

The low level pulse time must is longer than 300us, The following figure is the timing of reset function.

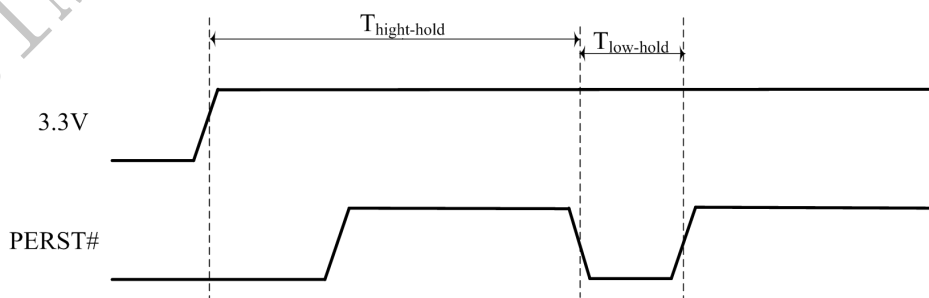

Figure 5: Reset Timing

4.7. W_DISABLE#

The W_DISABLE# pin controls SIM5360-PCIEA to enter or exit the Flight mode by default. In Flight mode, RF function is closed to prevent interference with other equipments or minimize current consumption.

Table 12: Flight mode control Function

W_DISABLE# status	Module operation
Low Level	Flight Mode: RF is closed.
High Level	Normal Mode: RF is working.

Table 13: W_DISABLE# Electrical Characteristic

Symbol	Parameter	Min	Type	Max	Unit
V _{IH}	High-level input voltage	3.0	3.3	3.6	V
V _{IL}	Low-level input voltage	-	-	0.3	V
T low-hold	low level hold on time	300	-	-	us

4.8. LED_WWAN#

The LED_WWAN# pin can be used to drive a network status indication LED by default. Its status is listed by following table.

Table 14: Network Status Indication Pin Status

LED_WWAN# Status	Working Status
On	Searching Network/Call Connect
200ms On, 200ms Off	Data Transmit
800ms On, 800ms Off	Registered network
Off	Power off / Sleep

Reference circuit is recommended in the following figure:

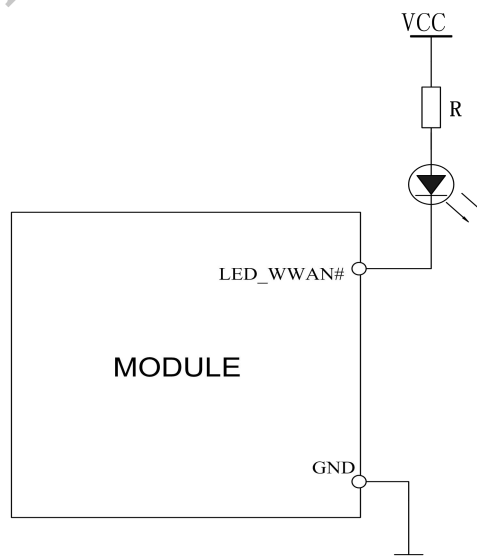

Figure 6: LED_WWAN# Reference Circuit

4.9. WAKE#

The WAKE# pin can be used as an interrupt signal to host. Normally it will keep high logic level until certain condition such as receiving SMS, voice call (CSD, video) or URC reporting, then WAKE# will change to low logic level to inform the master (client PC). It will stay low until the master clears the interrupt event with AT command.

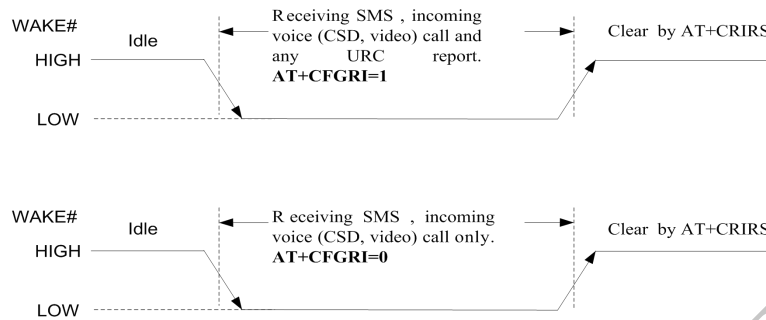

Figure 7: WAKE# behaviour

However, if the module is used as caller, the WAKE# will remain high. Please refer to the following figure.



Figure 8: WAKE# behavior as a caller

WAKE# Reference circuit is recommended in the following figure:

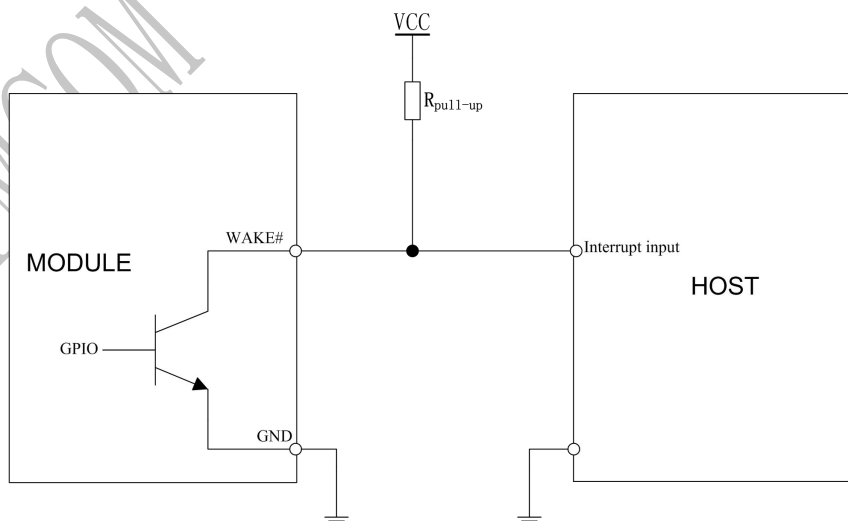

Figure 9: WAKE# Reference Circuit

Note: If Analog audio is available, wake up function is invalid. Please consult our sales staff, for more information .

4.10.UART Interface

SIM5360-PCIEA provides one UART (universal asynchronous serial transmission) port. The module is as the DCE (Data Communication Equipment) and the client PC is as the DTE (Data Terminal Equipment). AT commands are entered and serial communication is performed through UART interface.

In order to prevent the UART signals of the module damaged due to voltage spikes or ESD, series resistors can be used on UART signals.

The application circuit is in the following figures.

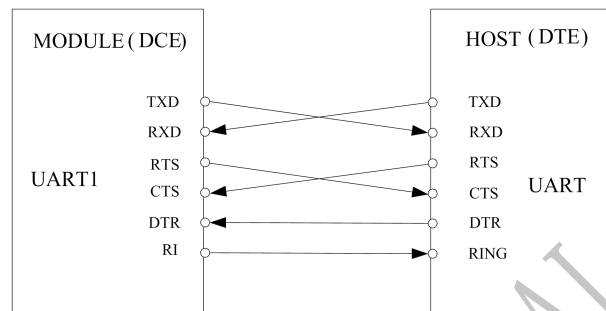

Figure 10: UART1 Full modem

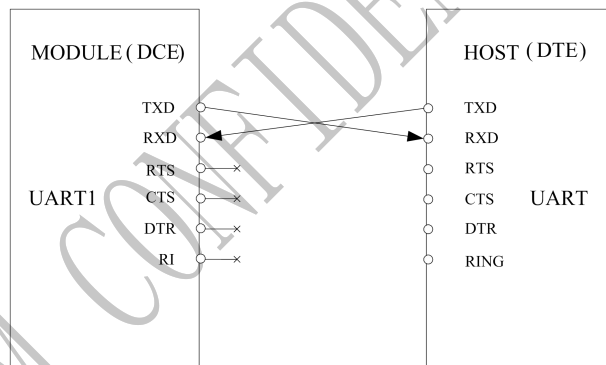

Figure 11: Null modem

Table 15: UART Electrical Characteristic

Symbol	Parameter	Min	Typ	Max	Unit
V _{IH}	High-level input voltage	1.26	1.8	2.1	V
V _{IL}	Low-level input voltage	-0.3	0	0.63	V
V _{OH}	High-level output voltage	1.35	1.8	1.8	V
V _{OL}	Low-level output voltage	0	0	0.45	V

The SIM5360-PCIEA UART is 1.8V interface. A level shifter should be used if user's application is equipped with a 3.3V UART interface. The level shifter TXB0108RGYR provided by Texas Instruments is recommended.

The reference design of the TXB0108RGYR is in the following figures.

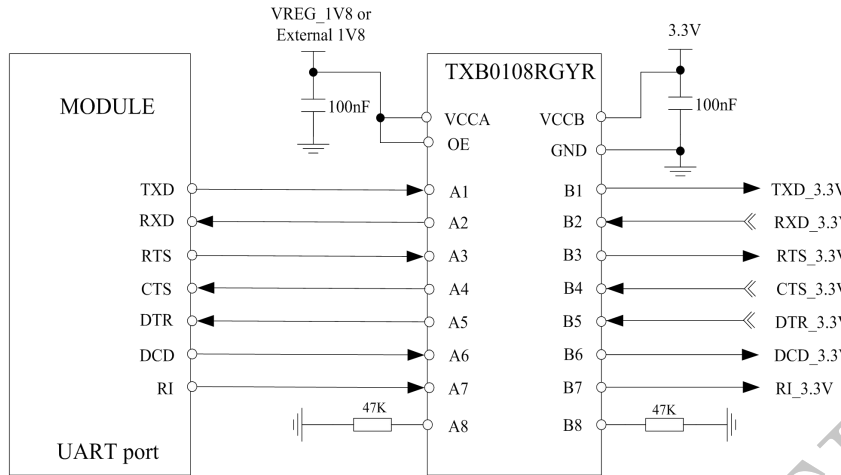

Figure 12: Reference circuit of level shift

To comply with RS-232-C protocol, the RS-232-C level shifter chip should be used to connect SIM5360-PCIEA to the RS-232-C interface. In this connection, the TTL level and RS-232-C level are converted mutually. SIMCom recommends that user uses the SP3238ECA chip with a full modem. For more information please refers to the RS-232-C chip datasheet.

Note: SIM5360-PCIEA supports the baud rate: 300, 600, 1200, 2400, 4800, 9600, 19200, 38400, 57600, 115200, 230400, 460800, 921600, 3200000, 3686400, 4000000bps. Default rate is 115200bps.

4.11.Audio Interfaces

SIM5360-PCIEA provides one analog signal output and one analog input. MIC1P/N is used as microphone, EAR1P/N is used as audio output. Regarding audio parameters configuration, please refer to the ATC manual.

Table 16: MIC input characteristics

Parameter	Min	Typ	Max	Unit
Working Voltage		1.80		V
Working Current	70		400	uA
External Microphone Load Resistance	1.2	2.2		k Ohms

Table 17: Audio output characteristics

Parameter	Min	Typ	Max	Unit		
Normal (EAR_P,EAR_N)	Differential	Load resistance	27	32	-	Ohm
		Output power	-	70	-	mW

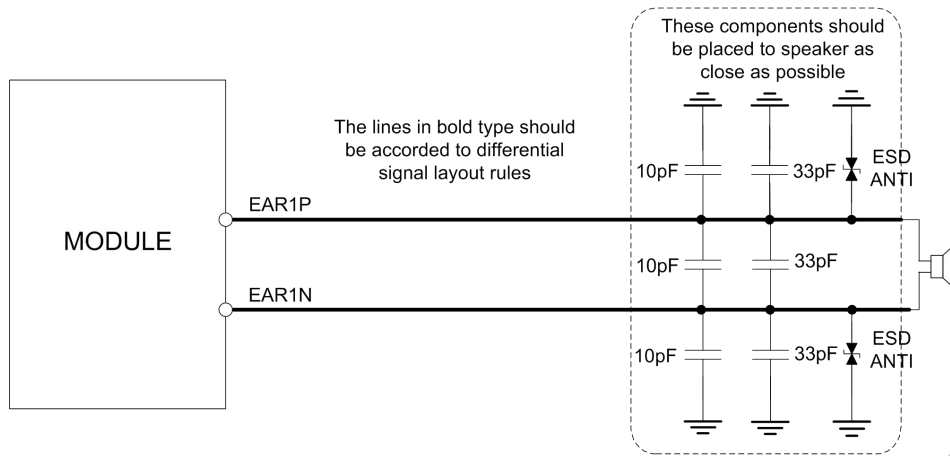

Figure 13: Receiver interface configuration

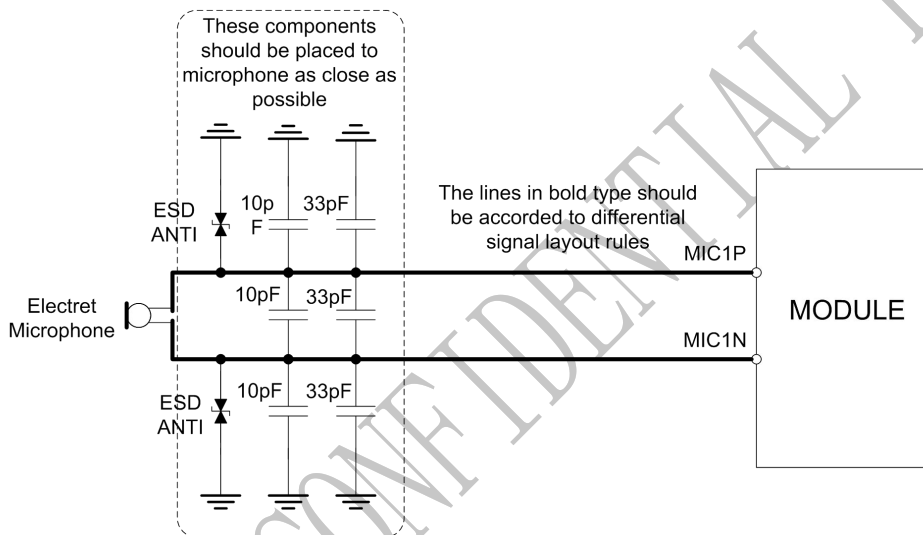

Figure 14: Microphone interface configuration

Note: SIM5360-PCIEA has integrated MIC bias circuit. There is no need to pull the MIC1P and MIC1N up to the external power, just connect it to microphone. MIC1P and MIC1N must be differential lines.

Main audio parameters can be changed to satisfy users' requirement. Here primary register parameters and related description are listed. User can adjust them through AT command. For more detail please refers to Audio Application Document.

Table 18: Audio parameter

Parameter	Influence to	Range	Gain range	Calculation	AT command
txVol	Digital gain of input signal after ADC	0, 1...65535	Mute, -84...+12dB	$20 * \log (txVol/16384)$	AT+CTXVOL
txFilter	Input PCM 13-tap filter parameters, 7 values	0...65535	---	MATLAB calculate	AT+CTXFTR

rxVol	Digital Volume of output signal after speech decoder, before summation of sidetone and DAC	-300...300	dbm	-300...300dbm	AT+CLVL AT+CVLVL AT+CRXVOL
stGain	Digital attenuation of sidetone	0, 1...65535	Mute, -96...0dB	20 * log (stGain/ 16384) -12	AT+SIDET
rxFilter	Output PCM 13-tap filter parameters, 7 values	0...65535	---	MATLAB calculate	AT+CRXFTR

Note: If users require better experience on audio, users should modify these parameters according to their own electronic and mechanical design.

4.12.GNSS (GPS and GLONASS)

SIM5360-PCIEA merges GNSS (GPS/GLONASS) satellite and network information to provide a high-availability solution that offers industry-leading accuracy and performance. This solution performs well, even in very challenging environmental conditions where conventional GNSS receivers fail, and provides a platform to enable wireless operators to address both location-based services and emergency mandates.

Technical specification

Tracking sensitivity	-159 dBm (GPS)	-158 dBm (GLONASS)
Cold-start sensitivity	-148 dBm	
Accuracy (Open Sky)	2.5m (CEP50)	
TTFB (Open Sky)	Hot start <1s	Cold start 35s
Receiver Type	16-channel, C/A Code	
	GPS L1 Frequency (1575.42±1.023MHz),	
	GLONASS: 1597.5~1605.8 MHz	
Update rate	Default 1 Hz	
GNSS data format	NMEA-0183	
GNSS Current consumption (WCDMA/GSM Sleep mode)	100mA (Total supply current)	
GNSS antenna	Passive/Active antenna	

Note: Performance will vary depending on the environment, antenna type and signal conditions and so on.

4.13.RF Antenna Connector

SIM5360-PCIEA have 3 antenna connectors, one of which is the main GSM/WCDMA antenna connector, the other is WCDMA diversity and GNSS antenna connector. Recommended antenna characteristics of SIM5360-PCIEA are described by 2 following tables.

Table 19: Recommended Passive Antenna Characteristics

Passive	Recommended standard
---------	----------------------

Direction	omnidirectional
Gain	> -3dBi (Avg)
Input impedance	50 ohm
Efficiency	> 50 %
VSWR	< 2

Table 20: Recommended Active Antenna Characteristics

Band	Performance	
	TRP	TIS
GSM850	≧ 29dBm	≧ -104dBm
EGSM900	≧ 29dBm	≧ -104dBm
DCS1800	≧ 26dBm	≧ -104dBm
PCS1900	≧ 26dBm	≧ -104dBm
WCDMA B1	≧ 19dBm	≧ -104dBm
WCDMA B2	≧ 19dBm	≧ -104dBm
WCDMA B5	≧ 19dBm	≧ -104dBm
WCDMA B8	≧ 19dBm	≧ -104dBm

SIMCOM CONFIDENTIAL FILE

5. Electrical, Reliability and Radio Characteristics

5.1. Absolute Maximum Ratings

The absolute maximum ratings are described by the following table. Module may be damaged beyond these ratings.

Table 21: Absolute maximum ratings

Symbol	Parameter	Min	Type	Max	Unit
V _{VCC}	VCC input voltage	0	-	3.6	V
I _{VCC}	VCC total peak current	0	-	2.0	A
I _I *	Input current	-	-	4	mA
I _O *	Output current	-	-	4	mA
V _{IO}	Voltage at digital pins (1.8v digital I/O)	-0.3	-	2.1	V

*Note: * These parameters are for digital interface pins, such as PCM.*

5.2. Recommended Operating Conditions

Please refer to the follow table for recommended operating conditions.

Table 22: Operating Conditions

Symbol	Parameter	Min	Type	Max	Unit
V _{VCC}	3.3V Input voltage	3.2	3.3	3.6	V
V _{IO}	Voltage at digital pins (1.8v digital I/O)	0	1.8	1.95	V
T _{OPER}	Operating temperature	-40	+25	+85	°C
T _{STG}	Storage temperature	-45	+25	+90	°C

5.3. SIM Card Interface Characteristics

Table 23: SIM Card Interface Characteristics

Symbol	Parameter	Min	Type	Max	Unit	
UIM_RST	V _{OH}	USIM_VDD=1.8V	1.62	-	-	V
		USIM_VDD=3.0V	2.7	-	-	V
	V _{OL}	USIM_VDD=1.8V	-	-	0.36	V

		USIM_VDD=3.0V	-	-	0.36	V
USIM_CLK	V _{OH}	USIM_VDD=1.8V	1.62	-	-	V
		USIM_VDD=3.0V	2.7	-	-	V
	V _{OL}	USIM_VDD=1.8V	-	-	0.216	V
		USIM_VDD=3.0V	-	-	0.4	V
USIM_DATA	V _{IH}	USIM_VDD=1.8V	1.4	-	-	V
		USIM_VDD=3.0V	2.6	-	-	V
	V _{IL}	USIM_VDD=1.8V	-	-	0.27	V
		USIM_VDD=3.0V	-	-	0.4	V
	V _{OH}	USIM_VDD=1.8V	1.4	-	-	V
		USIM_VDD=3.0V	2.6	-	-	V
	V _{OL}	USIM_VDD=1.8V	-	-	0.27	V
		USIM_VDD=3.0V	-	-	0.4	V

5.4. USIM_VDD Characteristics

Table 24: USIM_VDD Characteristics

Symbol	Parameter	Min	Type	Max	Unit
V _O	Output voltage	2.85	3.0	3.15	V
		1.7	1.80	1.9	
I _O	Output current	-	-	30	mA

5.5. Current Consumption (VCC =3.3V+0.3V/-0.1V)

Table 25: Current Consumption

GSM Sleep Mode (with USB suspended)	
GSM/GPRS supply current	Sleep @DRX=2 4.5mA
	Sleep @DRX=5 2.7mA
	Sleep @DRX=9 2.3mA
Voice Call	
GSM850	@power level #5 <300mA, Typical 263mA
GSM 900	@power level #5 <300mA, Typical 261mA
DCS1800	@power level #0 <250mA, Typical 218mA
PCS1900	@power level #0 <260mA, Typical 257mA
GPRS Data	
DATA mode, GPRS (1 Rx,4 Tx) CLASS 12	
GSM 850	@power level #5 <660mA, Typical 525mA
GSM 900	@power level #5 <660mA, Typical 480mA
DCS1800	@power level #0 <530mA, Typical 420mA
PCS1900	@power level #0 <530mA, Typical 420mA
DATA mode, GPRS (3Rx, 2 Tx) CLASS 12	

GSM 850	@power level #5 <460mA, Typical 360mA
GSM 900	@power level #5 <440mA, Typical 325mA
DCS1800	@power level #0 <400mA, Typical 285mA
PCS1900	@power level #0 <300mA, Typical 295mA
EDGE Data	
DATA mode, EDGE(1 Rx,4 Tx) CLASS 12	
GSM 850	@power level #8 <500mA, Typical 370mA
GSM 900	@power level #8 <500mA, Typical 365mA
DCS1800	@power level #2 <450mA, Typical 350mA
PCS1900	@power level #2 <450mA, Typical 350mA
DATA mode, EDGE(3Rx, 2 Tx) CLASS 12	
GSM 850	@power level #8 <330mA, Typical 250mA
GSM 900	@power level #8 <330mA, Typical 250mA
DCS1800	@power level #2 <300mA, Typical 225mA
PCS1900	@power level #2 <300mA, Typical 225mA
UMTS Sleep/Idle Mode (with USB suspended)	
WCDMA supply current	Sleep mode @DRX=9 1.8 mA
	Sleep mode @DRX=8 2.3 mA
	Sleep mode @DRX=6 3.6 mA
	Idle mode @DRX=6 32 mA
UMTS Talk	
WCDMA 2100	@Power 23dBm Typical 460 mA
	@Power 21dBm Typical 410 mA
	@Power 10dBm Typical 245 mA
WCDMA 1900	@Power 23dBm Typical 460 mA
	@Power 21dBm Typical 440 mA
	@Power 10dBm Typical 280 mA
WCDMA 850	@Power 23dBm Typical 440 mA
	@Power 21dBm Typical 400 mA
	@Power 10dBm Typical 250 mA
WCDMA 900	@Power 23dBm Typical 400 mA
	@Power 21dBm Typical 355 mA
	@Power 10dBm Typical 230 mA
HSDPA Data	
WCDMA 2100	@Power 23dBm CQI=22 Typical 520 mA
WCDMA 1900	@Power 23dBm CQI=22 Typical 510 mA
WCDMA 850	@Power 23dBm CQI=22 Typical 460 mA
WCDMA 900	@Power 23dBm CQI=22 Typical 450 mA

Note: In above table the current consumption value is the typical one of the module tested in laboratory. In the mass production stage, there may be differences among each individual.

5.6. Electro-Static Discharge

SIM5360-PCIEA is an ESD sensitive component, so more attention should be paid to the procedure of handling and packaging. The ESD test results are shown in the following table.

Table 26: ESD characteristics (Temperature: 25°C, Humidity: 45 %)

Pin	Contact discharge	Air discharge
VCC	±5KV	±10KV
GND	±5KV	±10KV
Antenna port	±5KV	±10KV
USB_DP,USB_DN	±4KV	±8KV

5.7. Radio Characteristics

5.7.1. Conducted Output Power

The following table shows SIM5360-PCIEA's conducted output power, comply with 3GPP TS 05.05 and TS 34.121.

Table 27: Conducted Output Power

Frequency	Max	Min
GSM850	33dBm ±2dB	5dBm ± 5dB
E-GSM900	33dBm ±2dB	5dBm ± 5dB
DCS1800	30dBm ±2dB	0dBm ± 5dB
PCS1900	30dBm ±2dB	0dBm ± 5dB
GSM850 (8-PSK)	27dBm ±3dB	5dBm ± 5dB
E-GSM900 (8-PSK)	27dBm ±3dB	5dBm ± 5dB
DCS1800 (8-PSK)	26dBm +3/-4dB	0dBm ±5dB
PCS1900(8-PSK)	26dBm +3/-4dB	0dBm ±5dB
WCDMA 2100	24dBm +1/-3dB	-56dBm ±5dB
WCDMA 1900	24dBm +1/-3dB	-56dBm ±5dB
WCDMA 850	24dBm +1/-3dB	-56dBm ±5dB
WCDMA 900	24dBm + 1/-3dB	-56dBm ±5dB

5.7.2. Conducted Receive Sensitivity

The following table shows conducted receiving sensitivity of SIM5360-PCIEA.

Table 28: Conducted Receive Sensitivity

Frequency	Receive sensitivity
GSM850	< -109dBm
E-GSM900	< -109dBm
DCS1800	< -109dBm
DCS1800	< -109dBm
WCDMA 2100	< -110dBm
WCDMA 1900	< -110dBm
WCDMA 850	< -110dBm
WCDMA 900	< -110dBm

Remark: The data in above table get at static condition.

5.7.3. Supported Band

The following table shows SIM5360-PCIEA supported band, and complies with 3GPP spec.

Table 29: Supported Band

Frequency	Receiving	Transmission
GSM850	869 ~894 MHz	824 ~849 MHz
E-GSM900	925 ~960 MHz	880 ~915 MHz
DCS1800	1805~1880 MHz	1710~1785 MHz
PCS1900	1930~1990 MHz	1850~1910 MHz
WCDMA 2100	2110~2170 MHz	1920~1980 MHz
WCDMA1900	1930~1990 MHz	1850~1910 MHz
WCDMA 850	869 ~894 MHz	824 ~849 MHz
WCDMA 900	925 ~960 MHz	880 ~915 MHz

SIMCOM CONFIDENTIAL FILE

6. Appendix

I. SIM5360-PCIEA Top and Bottom View

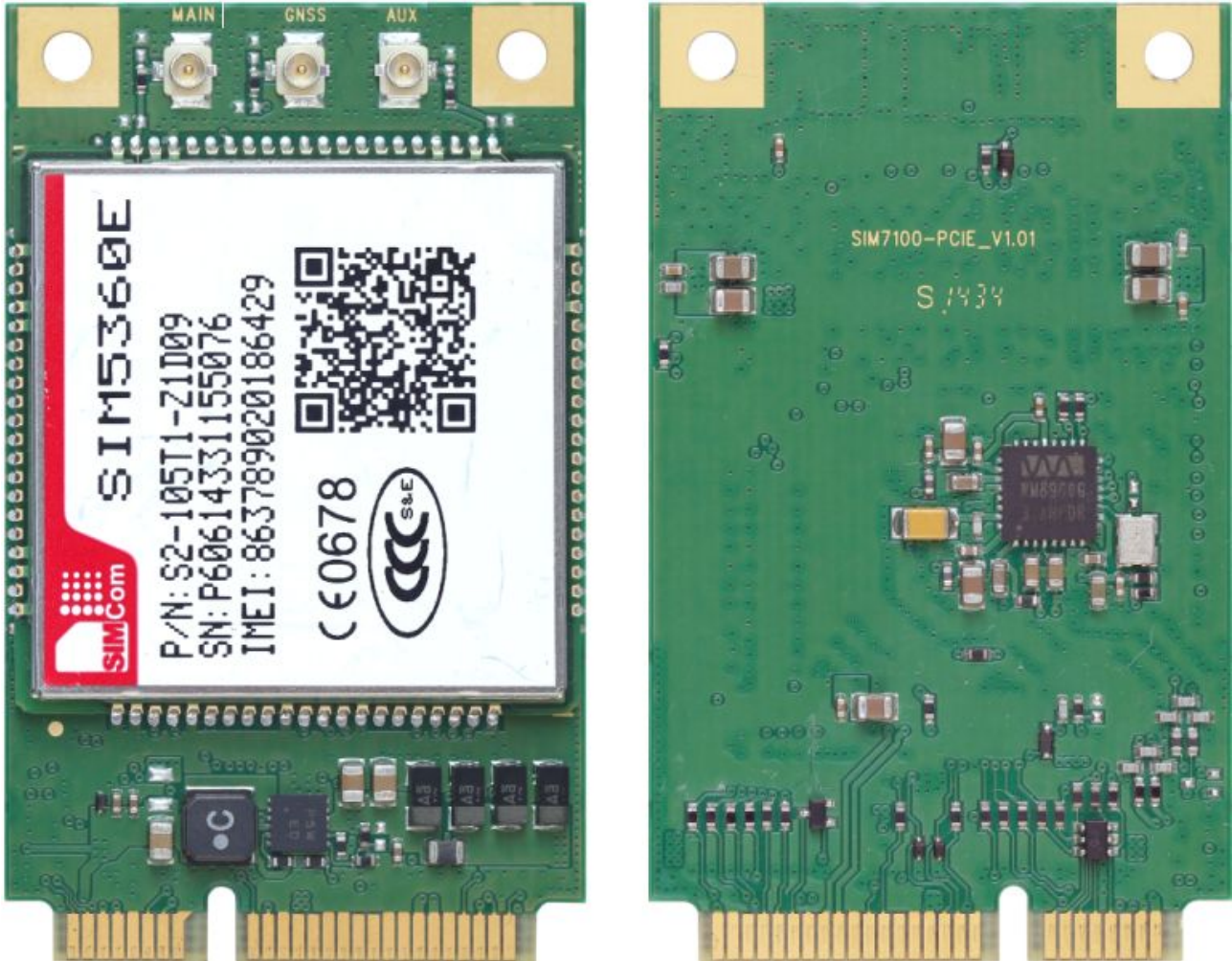

Figure 15: SIM5360-PCIEA Top and Bottom View

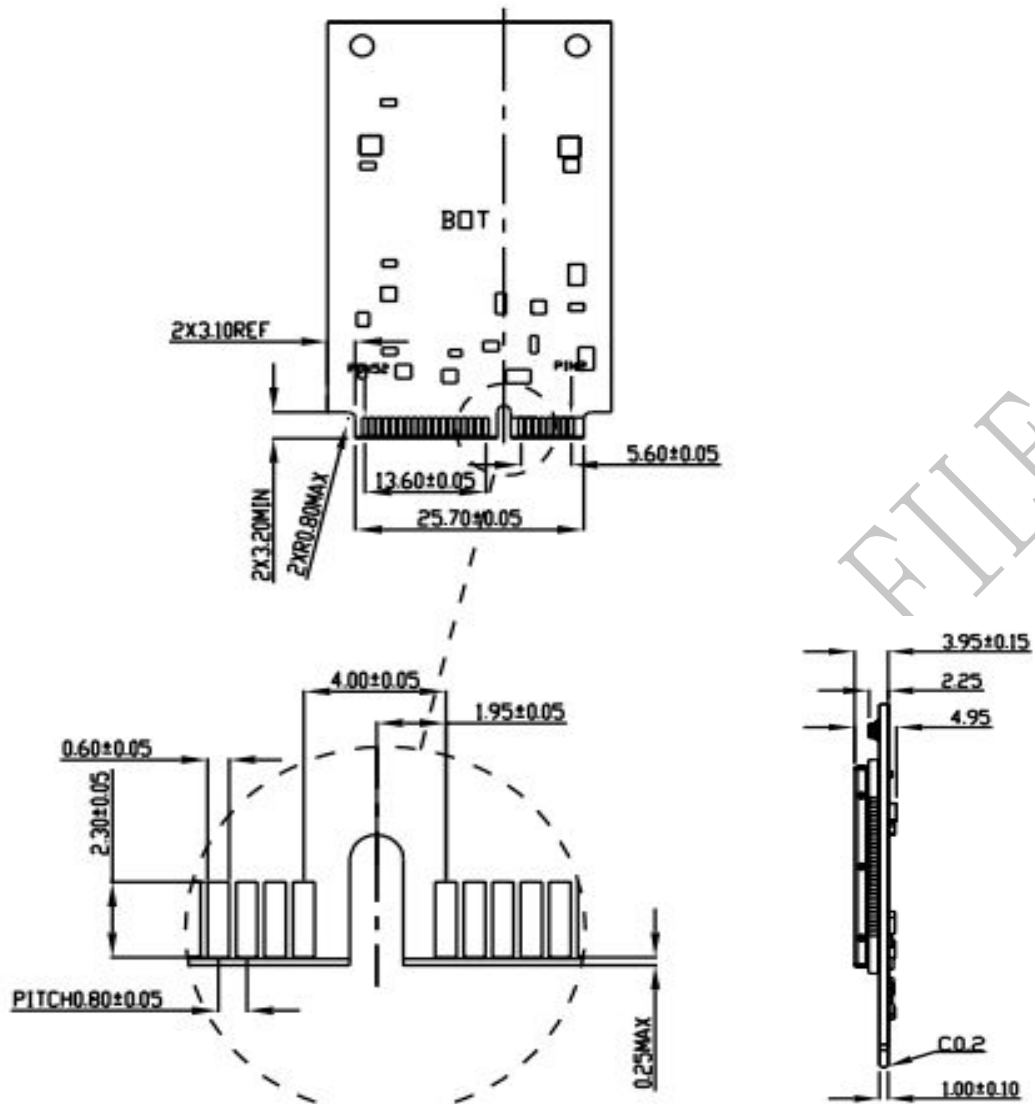

Figure 17: Dimensions of SIM5360-PCIEA (Unit: mm Bottom and Side view)

III. Related Documents

Table 30: Related Documents

SN	Document name	Remark
[1]	SIMCOM_SIM5360_ATC_EN_V1.XX.doc	
[2]	SIM5360_Audio_Application_Note	SIM5360_Audio_Application_Note
[3]	ITU-T Draft new recommendation V.25ter:	Serial asynchronous automatic dialing and control
[4]	GSM 07.07:	Digital cellular telecommunications (Phase 2+); AT command set for GSM Mobile Equipment (ME)
[5]	GSM 07.10:	Support GSM 07.10 multiplexing protocol
[6]	GSM 07.05:	Digital cellular telecommunications (Phase 2+); Use of Data Terminal Equipment – Data Circuit terminating Equipment (DTE – DCE) interface for Short Message Service (SMS) and Cell Broadcast Service (CBS)
[7]	GSM 11.14:	Digital cellular telecommunications system (Phase 2+); Specification of the SIM Application Toolkit for the Subscriber Identity Module – Mobile Equipment (SIM – ME) interface
[8]	GSM 11.11:	Digital cellular telecommunications system (Phase 2+); Specification of the Subscriber Identity Module – Mobile Equipment (SIM – ME) interface
[9]	GSM 03.38:	Digital cellular telecommunications system (Phase 2+); Alphabets and language-specific information
[10]	GSM 11.10	Digital cellular telecommunications system (Phase 2); Mobile Station (MS) conformance specification; Part 1: Conformance specification

IV. Terms and Abbreviations

Table 31: Terms and Abbreviations







Abbreviation	Description
ADC	Analog-to-Digital Converter
AMR	Adaptive Multi-Rate
CS	Coding Scheme
CSD	Circuit Switched Data
CTS	Clear to Send
DTE	Data Terminal Equipment (typically computer, terminal, printer)
DTR	Data Terminal Ready
DTX	Discontinuous Transmission
EFR	Enhanced Full Rate
EGSM	Enhanced GSM
ESD	Electrostatic Discharge
ETS	European Telecommunication Standard
FR	Full Rate
GPRS	General Packet Radio Service
GSM	Global Standard for Mobile Communications
HR	Half Rate
IMEI	International Mobile Equipment Identity
Li-ion	Lithium-Ion
MO	Mobile Originated
MS	Mobile Station (GSM engine), also referred to as TE
MT	Mobile Terminated
PAP	Password Authentication Protocol
PBCCH	Packet Broadcast Control Channel
PCB	Printed Circuit Board
PCL	Power Control Level
PCS	Personal Communication System, also referred to as GSM 1900
PDU	Protocol Data Unit
PPP	Point-to-point protocol
RF	Radio Frequency
RMS	Root Mean Square (value)
RTC	Real Time Clock
WCDMA	Wideband Code Division Multiple Access
HSDPA	High Speed Downlink Packet Access
HSUPA	High Speed Uplink Packet Access
RX	Receive Direction
SIM	Subscriber Identification Module
SMS	Short Message Service

TE	Terminal Equipment, also referred to as DTE
TX	Transmit Direction
UART	Universal Asynchronous Receiver & Transmitter
URC	Unsolicited Result Code
USSD	Unstructured Supplementary Service Data
Phonebook abbreviations	
FD	SIM fix dialing phonebook
LD	SIM last dialing phonebook (list of numbers most recently dialed)
MC	Mobile Equipment list of unanswered MT calls (missed calls)
ON	SIM (or ME) own numbers (MSISDNs) list
RC	Mobile Equipment list of received calls
SM	SIM phonebook
NC	Not connect

SIMCOM CONFIDENTIAL 1

V. Safety Caution

Table 32: Safety caution

Marks	Requirements
	When in a hospital or other health care facility, observe the restrictions about the use of mobiles. Switch the cellular terminal or mobile off, medical equipment may be sensitive to not operate normally for RF energy interference.
	Switch off the cellular terminal or mobile before boarding an aircraft. Make sure it is switched off. The operation of wireless appliances in an aircraft is forbidden to prevent interference with communication systems. Forget to think much of these instructions may lead to the flight safety or offend against local legal action, or both.
	Do not operate the cellular terminal or mobile in the presence of flammable gases or fumes. Switch off the cellular terminal when you are near petrol stations, fuel depots, chemical plants or where blasting operations are in progress. Operation of any electrical equipment in potentially explosive atmospheres can constitute a safety hazard.
	Your cellular terminal or mobile receives and transmits radio frequency energy while switched on. RF interference can occur if it is used close to TV sets, radios, computers or other electric equipment.
	Road safety comes first! Do not use a hand-held cellular terminal or mobile when driving a vehicle, unless it is securely mounted in a holder for hands free operation. Before making a call with a hand-held terminal or mobile, park the vehicle.
	<p>GSM cellular terminals or mobiles operate over radio frequency signals and cellular networks and cannot be guaranteed to connect in all conditions, for example no mobile fee or a invalid SIM card. While you are in this condition and need emergent help, please remember using emergency calls. In order to make or receive calls, the cellular terminal or mobile must be switched on and in a service area with adequate cellular signal strength.</p> <p>Some networks do not allow for emergency call if certain network services or phone features are in use (e.g. lock functions, fixed dialing etc.). You may have to deactivate those features before you can make an emergency call.</p> <p>Also, some networks require that a valid SIM card be properly inserted in the cellular terminal or mobile.</p>

Contact us:

Shanghai SIMCom Wireless Solutions Ltd.

Add: SIM Technology Building, No.633,Jinzhong Road, Changning District, Shanghai P.R. China 200335

Tel: +86 21 3235 3300

Fax: +86 21 3235 3301

URL: www.sim.com/wm

SIMCOM CONFIDENTIAL FILE