

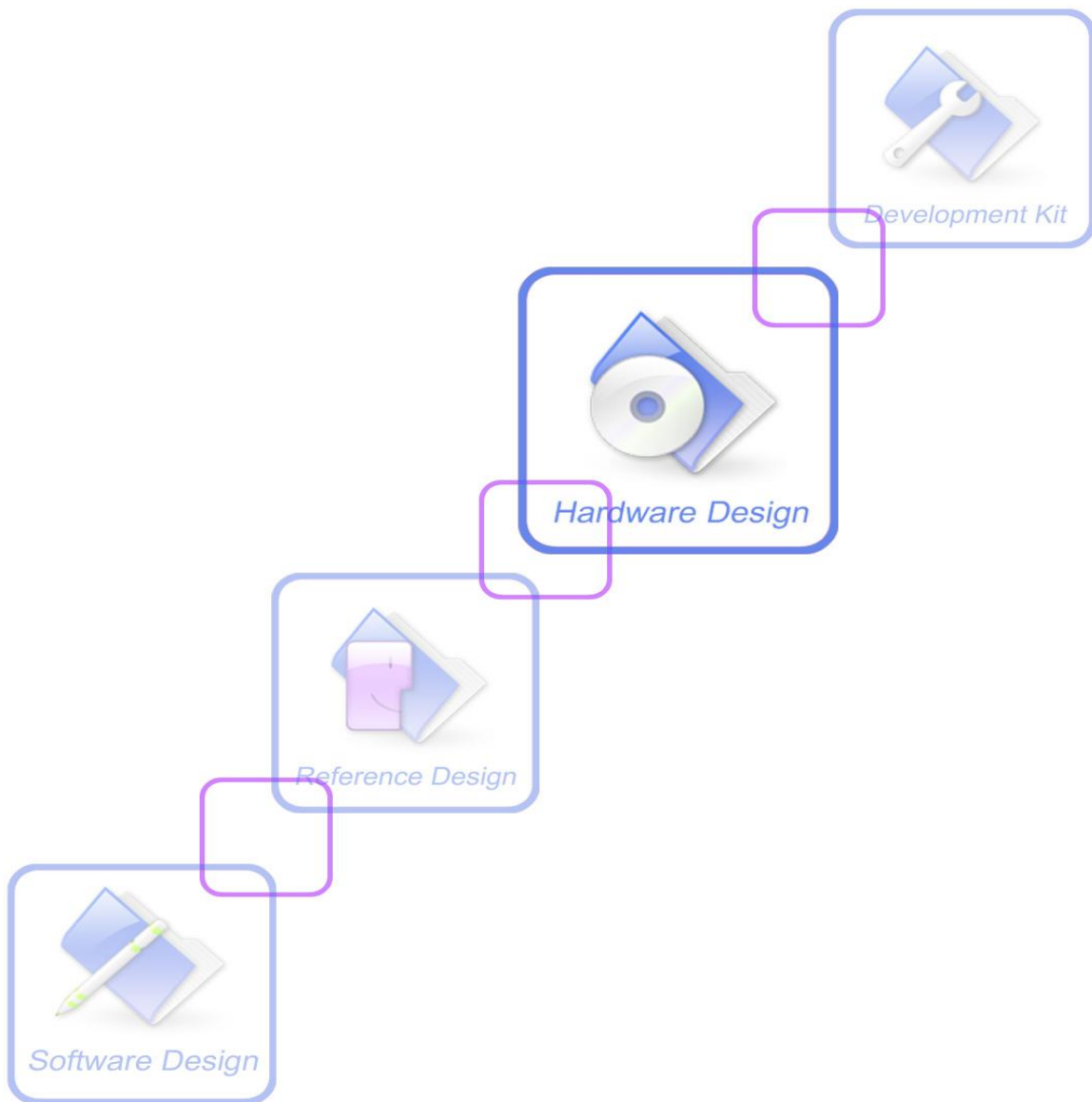

A company of SIM Tech

SIM33EAU_Hardware Design_V1.01



Document Title	SIM33EAU Hardware Design
Version	1.01
Date	2015-11-20
Status	Release
Document Control ID	SIM33EAU_Hardware Design_V1.01

General Notes

SIMCom offers this information as a service to its customers, to support application and engineering efforts that use the products designed by SIMCom. The information provided is based upon requirements specifically provided to SIMCom by the customers. SIMCom has not undertaken any independent search for additional relevant information, including any information that may be in the customer's possession. Furthermore, system validation of this product designed by SIMCom within a larger electronic system remains the responsibility of the customer or the customer's system integrator. All specifications supplied herein are subject to change.

Copyright

This document contains proprietary technical information which is the property of SIMCom Limited, copying of this document and giving it to others and the using or communication of the contents thereof, are forbidden without express authority. Offenders are liable to the payment of damages. All rights reserved in the event of grant of a patent or the registration of a utility model or design. All specification supplied herein are subject to change without notice at any time.

Copyright © Shanghai SIMCom Wireless Solutions Ltd. 2015

Contents

Contents	3
Version History	7
1 Introduction	8
2 SIM33EAU Overview	8
2.1 SIM33EAU Functional Diagram.....	9
2.2 GNSS Performance.....	9
2.3 General features.....	11
3 Package Information	12
3.1 Pin out Diagram.....	12
3.2 Pin Description.....	12
3.3 Package Dimensions.....	13
3.4 SIM33EAU Recommended PCB Decal.....	14
4 Application Interface	15
4.1 Power Management.....	15
4.1.1 Power Input.....	15
4.1.2 Starting SIM33EAU.....	15
4.1.3 Verification of SIM33EAU Start.....	15
4.1.4 Power Saving Modes.....	15
4.1.5 Operating Mode.....	16
4.1.5.1 Full on Mode.....	16
4.1.5.2 Standby Mode.....	16
4.1.6 V_BACKUP.....	17
4.1.7 Periodic Mode.....	17
4.2 UART Interface.....	17
4.3 3D-FIX Output.....	18
4.4 TIMEMARK Output.....	18
4.5 A-GPS.....	18
4.5.1 EPO.....	18
4.5.2 EASY MODE.....	19
4.5.3 DGPS.....	19
5 GNSS Antenna	20
5.1 Antenna specification.....	20
5.2 Application Notes.....	21
6 Electrical, Reliability and Radio Characteristics	23
6.1 Absolute Maximum Ratings.....	23
6.2 Recommended Operating Conditions.....	23
6.3 Electro-Static Discharge.....	24
7 Manufacturing	25
7.1 Top and Bottom View of SIM33EAU.....	25
7.2 Assembly and Soldering.....	25
7.3 Moisture sensitivity.....	26

7.4	ESD handling precautions	26
7.5	Shipment.....	27
8	Reference Design.....	28
Appendix	29
A.	Related Documents.....	29
B.	Terms and Abbreviations	29

SIMCOM CONFIDENTIAL FILE

Table Index

TABLE 1: GPS PERFORMANCE.....	9
TABLE 2: GENERAL FEATURES	11
TABLE 3: PIN DESCRIPTION	12
TABLE 4: POWER SUPPLY AND CLOCK STATE ACCORDING TO OPERATION MODE.....	16
TABLE 5: PSIMIPR NMEA PORT DATA RATE.....	17
TABLE 6: EFFICIENCY AND PEAK GAIN	20
TABLE 7: ANTENNA SPECIFICATIONS.....	21
TABLE 8: ABSOLUTE MAXIMUM RATINGS.....	23
TABLE 9: SIM33EAU OPERATING CONDITIONS	23
TABLE 10: SIM33EAU STANDARD I/O FEATURES	23
TABLE 11: THE ESD CHARACTERISTICS (TEMPERATURE: 25°C, HUMIDITY: 45 %).....	24
TABLE 12: MOISTURE CLASSIFICATION LEVEL AND FLOOR LIFE	26
TABLE 13: RELATED DOCUMENTS	29
TABLE 14: TERMS AND ABBREVIATIONS.....	29

SIMCOM CONFIDENTIAL FILE

Figure Index

FIGURE 1: SIM33EAU FUNCTIONAL DIAGRAM	9
FIGURE 2: SIM33EAU PIN OUT DIAGRAM (TOP VIEW).....	12
FIGURE 3: SIM33EAU MECHANICAL DIMENSIONS (UNIT: MM).....	13
FIGURE 4: RECOMMENDED PCB DECAL (TOP VIEW) (UNIT: MM).....	14
FIGURE 5: PERIODIC MODE.....	17
FIGURE 6: 3D GAIN PATTERN	20
FIGURE 7: BASIC FEATURES OF GPS PATCH ANTENNA.....	21
FIGURE 8: ILLUSTRATION OF THE SIM33EAU MODULE INSTALLATION	22
FIGURE 9: TOP AND BOTTOM VIEW OF SIM33EAU	25
FIGURE 10: THE RAMP-SOAK-SPIKE REFLOW PROFILE OF SIM33EAU.....	25
FIGURE 11: EXAMPLE APPLICATION SCHEMATIC WITH UART	28

SIMCOM CONFIDENTIAL FILE

Version History

Date	Version	Description of change	Author
2015-09-09	V1.01	Origin	Shengwu.Sun Lili.Teng
2015-11-20	V1.01		Shengwu.Sun

SIMCOM CONFIDENTIAL FILE

1 Introduction

This document describes the hardware interface of the SIMCom module SIM33EAU which can be used as a stand alone or A-GPS (Assisted Global Positioning System) receiver with a patch antenna on top of the module. As a wide range of applications can be integrated in SIM33EAU, all functional components of SIM33EAU are described in great detail.

2 SIM33EAU Overview

SIM33EAU is an ultra-compact POT (Patch on Top) GNSS module. With built-in LNA and Patch Antenna, SIM33EAU do not need an extra antenna. SIM33EAU can track as low as -165dBm signal even without network assistance. SIM33EAU has excellent low power consumption characteristic (acquisition 38mA, tracking 32mA). SIM33EAU supports various location and navigation applications, including autonomous GPS, GLONASS, GALILEO, QZSS, SBAS ranging (WAAS, EGNOS, GAGAN, MSAS), and A-GPS.

Key Features

- GNSS receiver supports GPS, GLONASS, GALILIRO, QZSS, SBAS ranging(WAAS/EGNOS/MSAS/GAGAN)
- 33tracking/99 acquisition channels
- Small footprint: 22 x 22 x 7.5mm, 16-pin LCC package
- 12 multi-tone active interference cancellers and jamming elimination
- Indoor and outdoor multi-path detection and compensation
- Max NMEA update rate up to 10 HZ
- Advanced software features
 1. EASY self-generated orbit prediction
 2. EPO/HotStill orbit prediction
 3. AlwaysLocate advanced location awareness technology
 4. supports logger function
 5. supports active interference cancellation (AIC)
- Pulse-per-second (PPS) GNSS time reference
 1. Adjustable duty cycle
 2. typical accuracy: ± 10 ns
- Interface
 - UART
- Operating temperature: -40 ~ +85 °C
- Accuracy 2.5m CEP
- RoHS compliant

The module provides complete signal processing from antenna input to host port in NMEA messages. The module requires 2.8V~4.3V power supply. The host port is configurable to UART. Host data and I/O signal levels are 2.85V CMOS compatible.

2.1 SIM33EAU Functional Diagram

The following figure shows a functional diagram of the SIM33EAU and illustrates the mainly functional parts:

- The GNSS chip
- SAW filter
- The antenna interface
- The communication interface
- The control signals

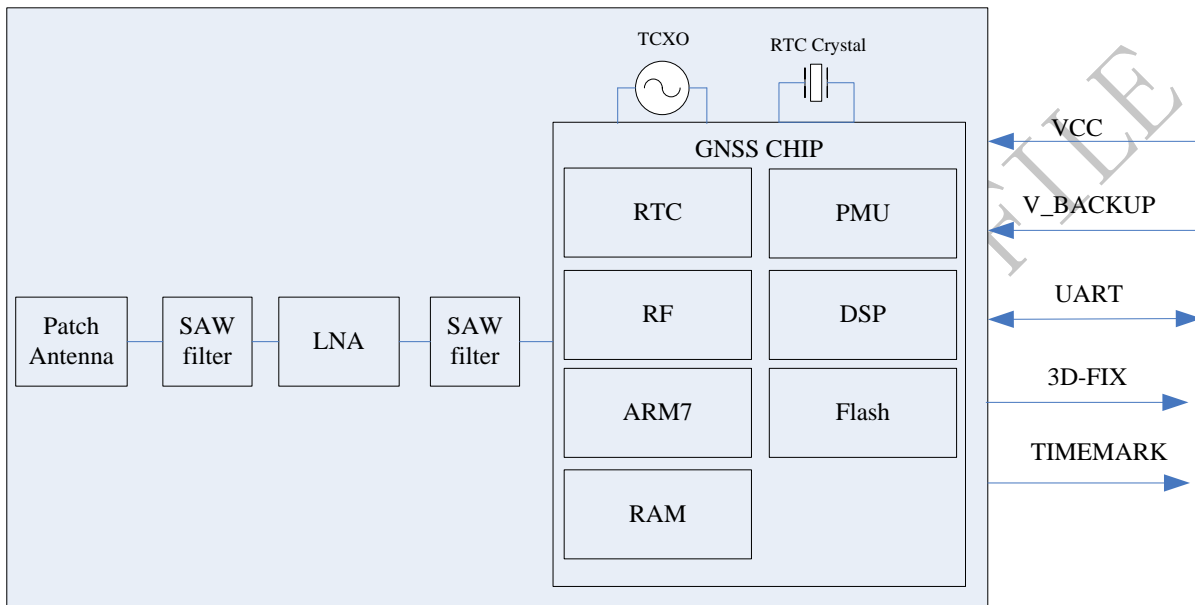

Figure 1: SIM33EAU functional diagram

2.2 GNSS Performance

Table 1: GNSS performance

Parameter	Description	Performance			
		Min	Type	Max	Unit
Horizontal Position Accuracy ⁽¹⁾	Autonomous		<2.5		m
Velocity Accuracy ⁽²⁾	Without Aid		0.1		m/s
	DGPS		0.05		m/s
Acceleration Accuracy	Without Aid		0.1		m/s ²
	DGPS		0.05		m/s ²
Timing Accuracy			10		ns
Dynamic Performance	Maximum Altitude			18000	m
	Maximum Velocity			515	m/s
	Maximum Acceleration			4	G
Time To First Fix ⁽³⁾	Hot start		<1		s
	Warm start		26		s

	Cold start		31		s
A-GPS TTFF(EPO in flash mode)	Hot start		0.5		s
	Warm start		1.8		s
	Cold start		14.8		s
Sensitivity ⁽⁷⁾	Autonomous acquisition(cold start)		-146		dBm
	Re-acquisition		-160		dBm
	Tracking		-165		dBm
Receiver	Channels		33tracking/99acqui sition		
	Update rate			10	Hz
	Tracking L1, CA Code				
	Protocol support NMEA,PMTK				
Power consumption ⁽⁴⁾	Acquisition		38		mA
	Continuous tracking		32		mA
	Standby current		520		uA
	Backup current		13		uA
Power consumption ⁽⁵⁾	Acquisition		28		mA
	Continuous tracking		28		mA
	Standby current		520		uA
	Backup current		13		uA
Power consumption ⁽⁶⁾	Acquisition		28		mA
	Continuous tracking		32		mA
	Standby current		520		uA
	Backup current		13		uA

(1) 50% 24hr static, -130dBm

(2) 50% at 30m/s

(3) -130 dBm, GPS&GLONASS mode

(4) Single Power supply 3.3V under GPS+GLONASS signal@-130dBm

(5) Single Power supply 3.3V under GPS signal@-130dBm

(6) Single Power supply 3.3V under GLONASS signal@-130dBm

(7) Single Power supply 3.3V under GPS+GLONASS signal

2.3 General features

Table 2: General features

Parameters		Value
Supply voltage VCC		+2.8V~4.3V
Supply voltage ripple VCC		54 mV(RMS) max @ f = 0~3MHz 15 mV(RMS) max @ f > 3 MHz
Power consumption(acquisition)		38mA type. @ VCC=3.3 V
Power consumption(standby)		520uA type. @ VCC=3.3 V
Storage temperature		-40 ℃~+85 ℃
Operating temperature		-40 ℃~+85 ℃ (note 1)
I/O signal levels	VIL	-0.3V~0.8V
	VIH	2.0V~3.3V
	VOL	-0.3V~0.4V
	VOH	2.4V~3.1V
I/O output sink/source capability		+/- 3mA max
I/O input leakage		+/- 10 uA max
Host port		UART
Other port		3D-FIX
Serial port protocol (UART)		NMEA; 8 bits, no parity, 1 stop bit; 115200 baud (configurable)
TIMEMARK output (1PPS)		1 pulse per second, synchronized at rising edge, pulse length 100ms

Note 1: Operation in the temperature range -40 ℃~-30 ℃ is allowed but Time-to-First-Fix performance and tracking sensitivity may be degraded.

3 Package Information

3.1 Pin out Diagram

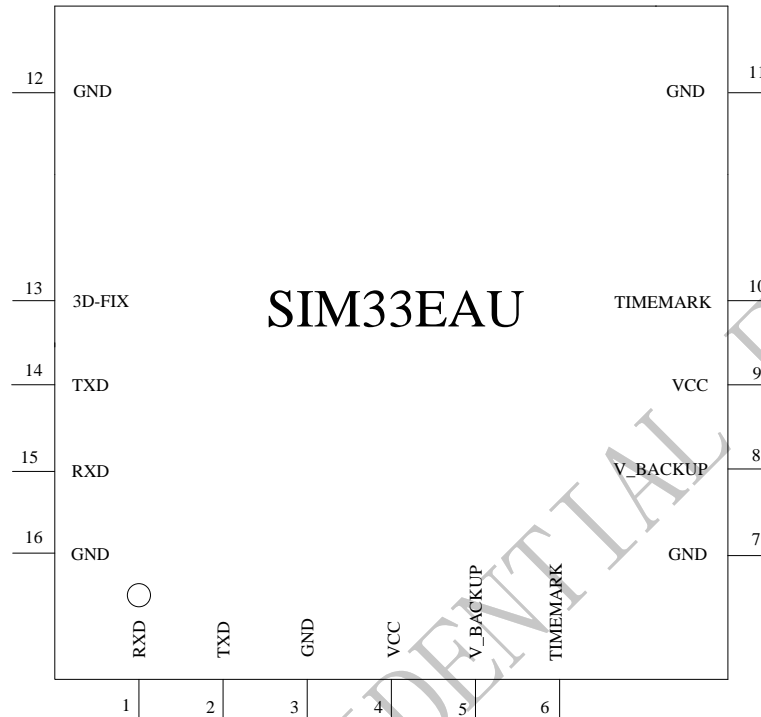

Figure 2: SIM33EAU pin out diagram (Top view)

3.2 Pin Description

Table 3: Pin description

Pin name	Pin number	I/O	Description	Comment
Power supply				
VCC	4,9	I	Main power input, which will be used to power the baseband and RF section internally.	Provide clean and stable power source to this pin. Add a 4.7uF capacitor to this pin for decoupling.
V_BACKUP	5,8	I	The backup battery input power supply for RTC	If unused, keep open.
GND	7,11,12,16		Ground	GND
Host port interface				
TXD	2,14	O	Serial output	

RXD	1,15	I	Serial input	
GPIOs				
TIMEMARK	6,10	O	Time Mark outputs timing pulse related to receiver time	If unused, keep open.
3D-FIX	13	O	3D-fix indicator	

3.3 Package Dimensions

Following figure shows the Mechanical dimensions of SIM33EAU (top view, side view and bottom view).

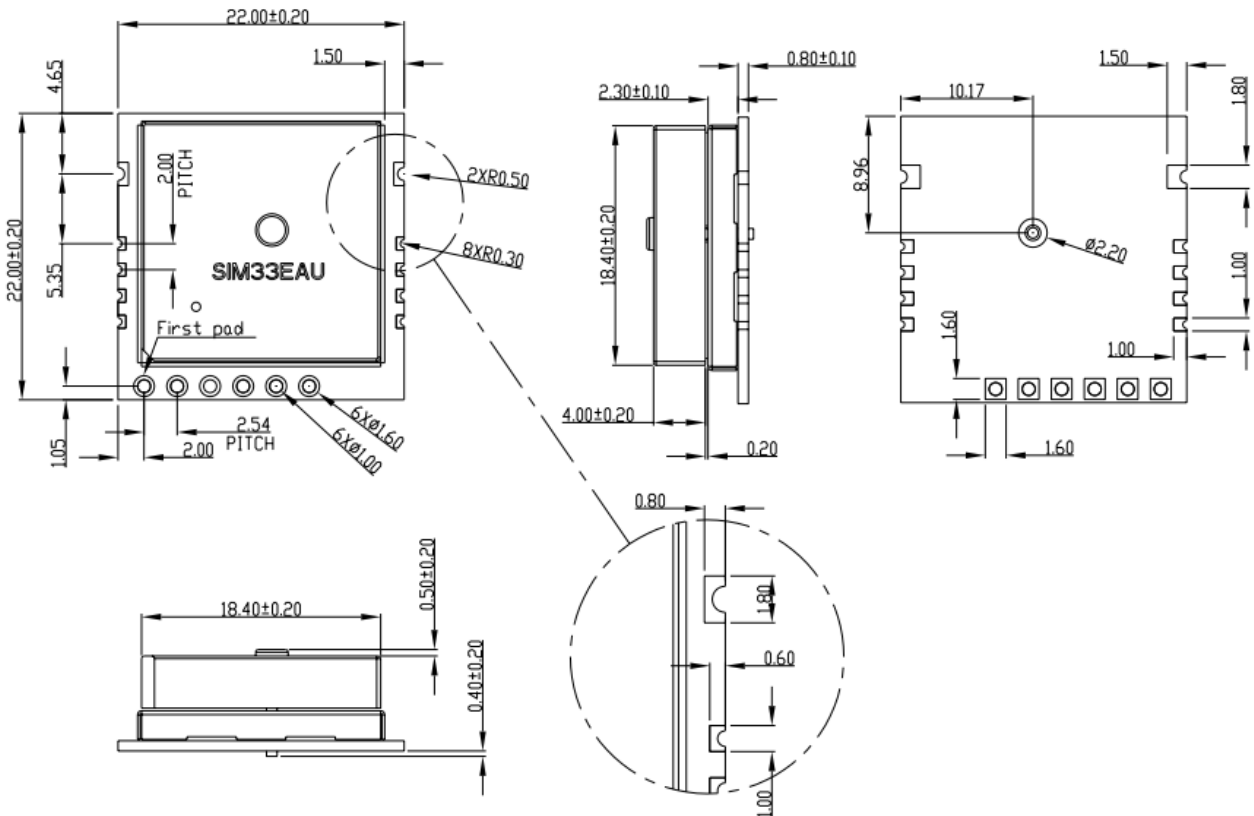

Figure 3: SIM33EAU mechanical dimensions (Unit: mm)

4 Application Interface

4.1 Power Management

4.1.1 Power Input

The power supply (VCC) range of SIM33EAU is from 2.8V to 4.3V. The power supply should be able to provide sufficient current up to 100mA.

4.1.2 Starting SIM33EAU

When power is first applied, SIM33EAU goes into operation mode.

4.1.3 Verification of SIM33EAU Start

System activity indication depends upon the chosen serial interface:

- When it is activated, SIM33EAU will output messages at the selected UART speed and message types.

4.1.4 Power Saving Modes

SIM33EAU supports operating modes for reduced average power consumption like standby mode, backup mode, periodic mode, and AlwaysLocate™ mode.

- **Standby mode:** In this mode the receiver stays at full on power state. When this mode that can be wake up by the host sends the command through the communication interface.

Note: using the PMTK161 command

*"\$PMTK161,0*28" Stop mode;*

*"\$PMTK161,1*29" into Sleep mode; but also to stop the NMEA output; Serial any character, the StandbyPin pin can rise along the wake, wake up after the longer dormancy.*

'0' = Stop mode, stop NMEA output, the receiver stays at ultra low power state

'1' = Sleep mode, stop NMEA output, the receiver stays at full on power state

- **Backup mode:** In this mode the SIM33EAU must be supplied by the backup and it can help to count down the time for backup mode. Software on host side to send the command through the communication interface.

*Note: backup mode, the first "\$PMTK225,0*2B" again "\$PMTK225,4*2F" into a permanent backup mode, cannot be serial, StandbyPin pin wake.*

- **Periodic mode:** In this mode the SIM33EAU enters tracking modes according to the interval configured by users in the commands.

Note: Also called Period Standby mode, note: using the PMTK225 command

*"\$PMTK225,0*2B"*

*"\$PMTK223,1,2518000060000*38"*

*"\$PMTK225,23000120001800072000*15"*

Run for 3 seconds, 12 seconds of sleep, so the cycle; be serial any string after awakening was no longer dormancy,

StandbyPin can continue into periodic sleep state after awakening

- AlwaysLocate™ mode: AlwaysLocate™ is an intelligent controller of SIM33EAU periodic mode. Depending on the environment and motion conditions, SIM33EAU can adaptive adjust the on/off time to achieve balance of positioning accuracy and power consumption.

Note: AlwaysLocate™ Standby

`"$PMTK225,0 " "$PMTK225,8 "`

AlwaysLocate™ Backup"

`"$PMTK225,0 " "$PMTK225,9"`

'8': AlwaysLocate™ standby mode

'9': AlwaysLocate™ backup mode

Note: the modes mentioned above are operated by PMTK commands, users can refer to document [1] for more information.

SIM33EAU provides very low leakage battery back up memory, which contains all the necessary GNSS information for quick start up and a small amount of user configuration variables. It needs a 3V power supply for V_BACKUP pin.

4.1.5 Operating Mode

Table 4: Power supply and clock state according to operation mode

Mode	VCC	V_BACKUP	Internal LDO	Main clock	RTC clock
Full on	on	on	on	on	on
Standby	on	on	on	off	on
Backup	off	on	off	off	on

4.1.5.1 Full on Mode

The module will enter full on mode after first power up with factory configuration settings. Power consumption will vary depending on the amount of satellite acquisitions and number of satellites in track. This mode is also referenced as Full on, Full Power or Navigation mode.

Navigation is available and any configuration settings are valid as long as the VCC power supply is active. When the power supply is off, settings are reset to factory configuration and receiver performs a cold start on next power up.

4.1.5.2 Standby Mode

Standby mode means a low quiescent (520uA type.) power state, non-volatile RTC and backup RAM block are powered on. Other internal blocks like digital baseband and RF are internally powered off. The power supply input VCC shall be kept active all the time, even during Standby mode.

Sending PMTK command through communication interface by host side can enter standby mode, and any byte typing in will wake up module form standby mode;

4.1.6 V_BACKUP

This connects to the backup power of the GNSS module. Power source (such as battery or LDO) connected to this pin will help the GNSS chipset keep its internal RTC running while the main power source is turned off. The voltage should be kept between 2.0~4.3V, Typical value is 3.0V.

If V_BACKUP power was not reserved, the GNSS module will perform a lengthy cold start every time it is power-on. If not used, keep open.

4.1.7 Periodic Mode

In this mode, SIM33EAU will enter tracking, standby or Backup mode according to the interval configured by users.

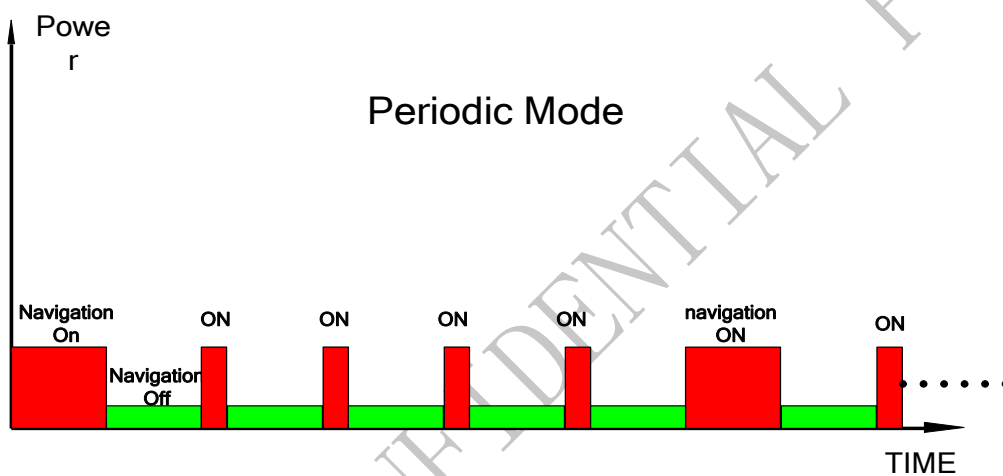

Figure 5: Periodic Mode

4.2 UART Interface

SIM33EAU contains one UART interface for serial communication, supporting NMEA output and PMTK command input.

The receiver (RXD) and transmitter (TXD) side of every port contains a 16-byte FIFO and has 256 bytes URAM. UART can provide the developers signal or message outputs. The baud rates are selectable and ranging from 4.8 to 921.6kbps through PMTK commands, please refer to the following table for details.

For details about CoreBuilder information, please refer to document [1]

Table 5: PSIMIPR NMEA port data rate

PSIMIPR NMEA port data rate	
Example: \$PSIMIPR,W,115200*1C	
Test Command PSIMIPR,T	Response PSIMIPR,T,(0,4800,9600,14400,19200,38400,57600,115200)
	Parameters See Write Command

<p>Write Command PSIMIPR,W,<baud rate></p>	<p>Response</p> <p>If success, return : PSIMIPR,W,Ok</p> <p>If error, return : PSIMIPR,W>Error</p> <p>Parameters</p> <p><baud rate> support default baud rate(0) or 4800,9600,14400,19200,38400,57600,115200</p>
<p>Read Command PSIMIPR,R</p>	<p>Response</p> <p>TA returns the current debug information output control PSIMIPR,R,Ok, < baud rate></p> <p>Parameters</p> <p>See Write Command</p>

Note:

1. 0 means default baud rate.
2. Need module reset or Cold/Warm/Hot/Full cold start to take effect.

4.3 3D-FIX Output

The 3D-FIX is assigned as a fix flag output. This pin will output high after successful positioning.

4.4 TIMEMARK Output

The TIMEMARK pin outputs pulse-per-second (1PPS) pulse signal for precise timing purposes. The Timemark signal can be provided through designated output pin for many external applications. This pulse is not only limited to be active every second but also allowed to set the required duration, frequency, and active high/low by programming user-defined settings.

4.5 A-GPS

A-GPS is the meaning of Assisted GNSS, which is a system that can improve the startup performance and time-to-first-fix (TTFF) of a GNSS satellite-based positioning under certain conditions. SIM33EAU module supports EPO file, EASY MODE and SBAS

4.5.1 EPO

The SIM33EAU supports the EPO (Extended Prediction Orbit) data service. The EPO data service supports 7/14/30 days orbit prediction to customers. It needs to download from EPO server occasionally. Supply of aiding information like ephemeris, almanac, rough last position and time and satellite status and an optional time synchronization signal will reduce time to first fix significantly and improve the acquisition sensitivity.

User should update the EPO files from EPO server daily through the internet. Then EPO data should be sent to SIM33EAU by HOST side. SIM33EAU will have shorter cold TTFF and warm TTFF, when the A-GPS is used.

Note: For more information about EPO, please contact SIMCom sales. User can refer to document [2] for more information

4.5.2 EASY MODE

EASY is the abbreviation of Embedded Assist System, it works as embedded firmware which accelerates TTFF by predicting satellite navigation messages from received ephemeris.

No additional computing interval for EASY task. EASY is efficiently scheduled and computed in free time of every second after GNSS navigation solution.

EASY function is conceptually designed to automatically engage for predicting after first receiving the broadcast ephemeris. After a while (generally tens of seconds), 3-day extensions will be completely generated then all EASY functions will be maintained at a standby condition. EASY assistance is going to be engaged when the GNSS requests in new TTFF condition or re-generates again with another new received ephemeris. Meanwhile, TTFF will be benefited by EASY assistance.

Note: EASY function is default open and can be closed by PMTK command.

4.5.3 DGPS

SBAS is the abbreviation of Satellite Based Augmentation System. The SBAS concept is based on the transmission of differential corrections and integrity messages for navigation satellites that are within sight of a network of reference stations deployed across an entire continent. SBAS messages are broadcast via geostationary satellites able to cover vast areas.

Several countries have implemented their own satellite-based augmentation system. Europe has the European Geostationary Navigation Overlay Service (EGNOS) which covers Western Europe and beyond. The USA has its Wide Area Augmentation System (WAAS). Japan is covered by its Multi-functional Satellite Augmentation System (MSAS). India has launched its own SBAS program named GNSS and GEO Augmented Navigation (GAGAN) to cover the Indian subcontinent.

5 GNSS Antenna

5.1 Antenna specification

As mentioned above, SIM33EAU has integrated a GPS/GLONASS antenna internal, which is a passive patch antenna, with a tiny size of 18.4mm*18.4mm*4mm. Owing to this feature, the user does not need the necessary of choosing and tuning the GPS/GLONASS antenna additionally.

The specifications and performance of the integrated GPS/GLONASS antenna are presented as following table:

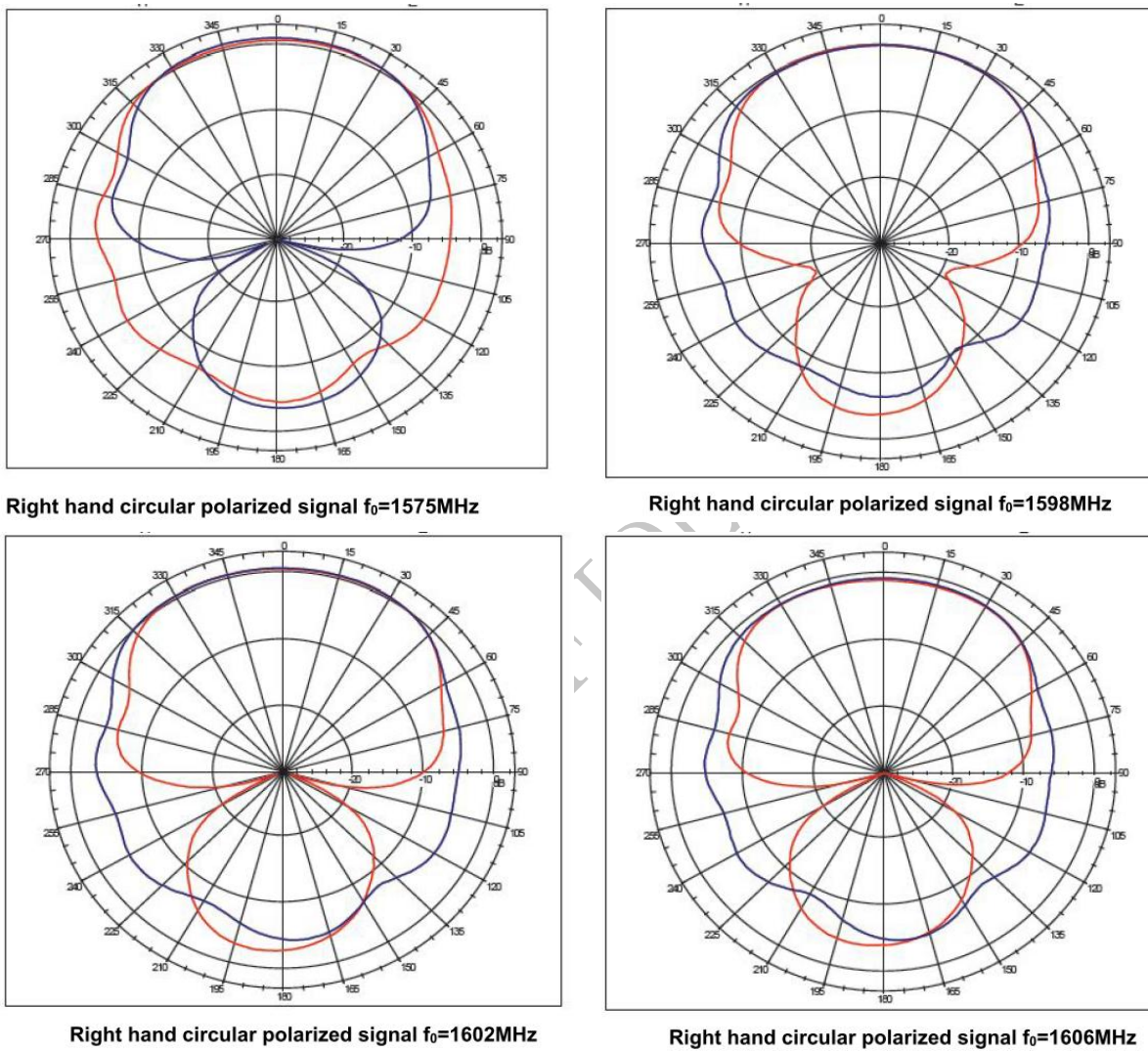

Figure 6: 2D gain pattern

Table 6: Antenna Specifications——GPS

Parameter	Specification	Passive and active antenna
GPS/GLONASS Patch Antenna	Frequency range	1575±2.5MHz
	Polarization	RHCP
	Gain at Zenith	1.5dBic
	VSWR	<2 dB
	Impedance(Ω)	50

Table 7: Antenna Specifications——GLONASS

Parameter	Specification	Passive and active antenna
GPS/GLONASS Patch Antenna	Frequency range	1602±5MHz
	Polarization	RHCP
	Gain at Zenith	1.5dBic
	VSWR	<2 dB
	Impedance(Ω)	50

5.2 Application Notes

The GPS Patch antenna consists of a radiating patch on one side of a dielectric material substrate backed by a ground plane on the other side, as shown in figure 7:

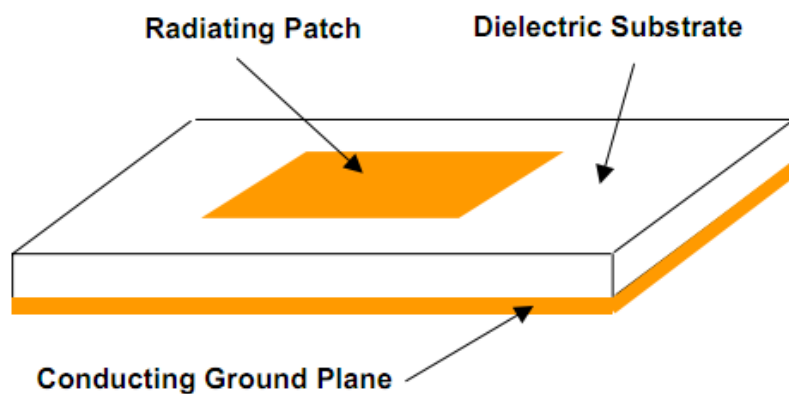
Figure 7: Basic features of GPS patch antenna

When the SIM33EAU is integrated into customer's product, the following rules should be followed strictly.

1. The most important rule is to ensure the antenna towards the sky.
2. The antenna should not be covered by any metal device or metalized enclosure. It is because the metal device will block the most GPS signal reaching to the antenna.
3. The height of the device around the module should not exceed the antenna at least. Otherwise, the antenna performance will be affected more or less.
4. The device carried large amounts of interfering signals around the module, should be placed far away from the module, or should be shielded by a shielding can.

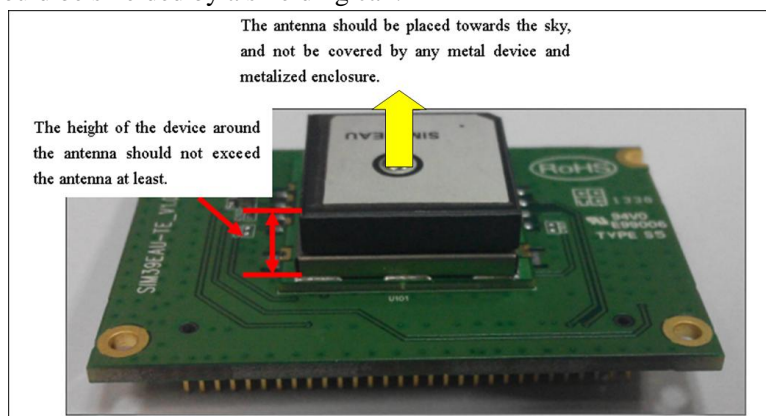

(a)

The device carry large amounts of interfering signals should be placed far away from the antenna, or should be shielded by shielding can.

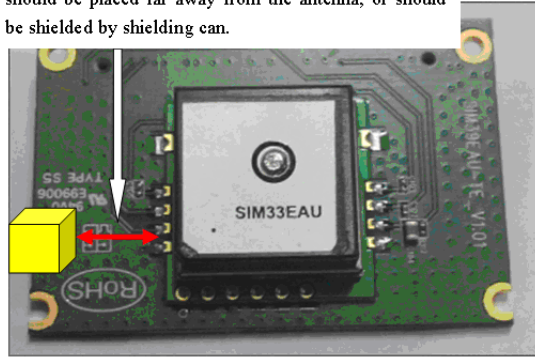

(b)

Figure 8: Illustration of the SIM33EAU module installation

SIMCOM CONFIDENTIAL FILE

6 Electrical, Reliability and Radio Characteristics

6.1 Absolute Maximum Ratings

The absolute maximum ratings stated in Table 8 are stress ratings under non-operating conditions. Stresses beyond any of these limits will cause permanent damage to SIM33EAU.

Table 8: Absolute maximum ratings

Parameter	Min	Max	Unit
VCC	-	4.3	V
Input Power at RF_IN	-	-12	dBm
V_BACKUP	-	4.3	V
I/O pin voltage	-	3.6	V
Storage temperature	-45	+125	°C
Operating Temperature	-40	+85	°C

6.2 Recommended Operating Conditions

Table 9: SIM33EAU operating conditions

Parameter	Symbol	Min	Typ	Max	Unit
Operating temperature range		-40	+25	+85	°C
Main supply voltage	VCC	2.8	3.3	4.3	V
Backup battery voltage	V_BACKUP	2	3	4.3	V

Table 10: SIM33EAU standard I/O features

Parameter	Symbol	Min	Typ	Max	Unit
Low level output voltage Test conditions $I_{OL} = 2\text{mA}$ and 4.0mA	V_{OL}	-0.3		0.40	V
High level output voltage Test conditions $I_{OL} = 2\text{mA}$ and 4.0mA	V_{OH}	2.4		3.1	V
Low level input voltage	V_{IL}	-0.3		0.8	V
High level input voltage	V_{IH}	2.0		3.6	V
Input Pull-up resistance	R_{PU}	40		190	K Ω
Input Pull-down resistance	R_{PD}	40		190	K Ω
Input capacitance	C_{IN}		5		pF
Load capacitance	C_{load}			8	pF
Tri-state leakage current	I_{OZ}	-10		10	μA

6.3 Electro-Static Discharge

The GNSS engine is not protected against Electrostatic Discharge (ESD) in general. Therefore, it is subject to ESD handling precautions that typically apply to ESD sensitive components. Proper ESD handling and packaging procedures must be applied throughout the processing, handling and operation of any application using a SIM33EAU module. The ESD test results are shown in the following table.

Table 11: The ESD characteristics (Temperature: 25°C, Humidity: 45 %)

Pin	Contact discharge	Air discharge
VCC	±5KV	±10KV
Antenna	±5KV	±10KV
V_BACKUP	±5KV	±10KV
GND	±5KV	±10KV
TXD, RXD	±4KV	±8KV
3D-FIX	±4KV	±8KV
TIMEMARK	±4KV	±8KV

SIMCOM CONFIDENTIAL

7 Manufacturing

7.1 Top and Bottom View of SIM33EAU

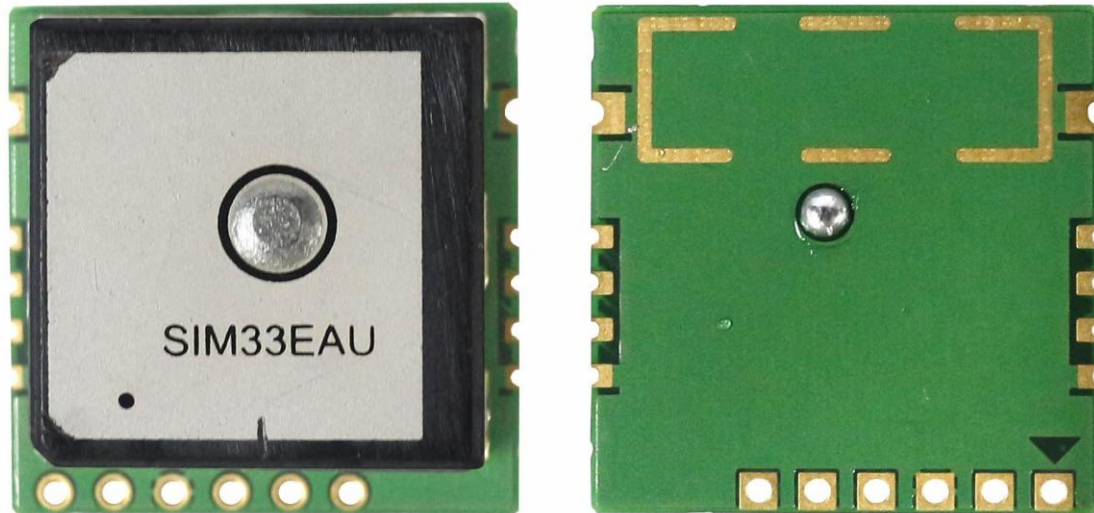

Figure 9: Top and bottom view of SIM33EAU

7.2 Assembly and Soldering

The SIM33EAU module is intended for SMT assembly and soldering in a Pb-free reflow process on the top side of the PCB. Suggested solder paste stencil height is 150um minimum to ensure sufficient solder volume. If required paste mask pad openings can be increased to ensure proper soldering and solder wetting over pads. The following figure is the Ramp-Soak-Spike Reflow Profile of SIM33EAU:

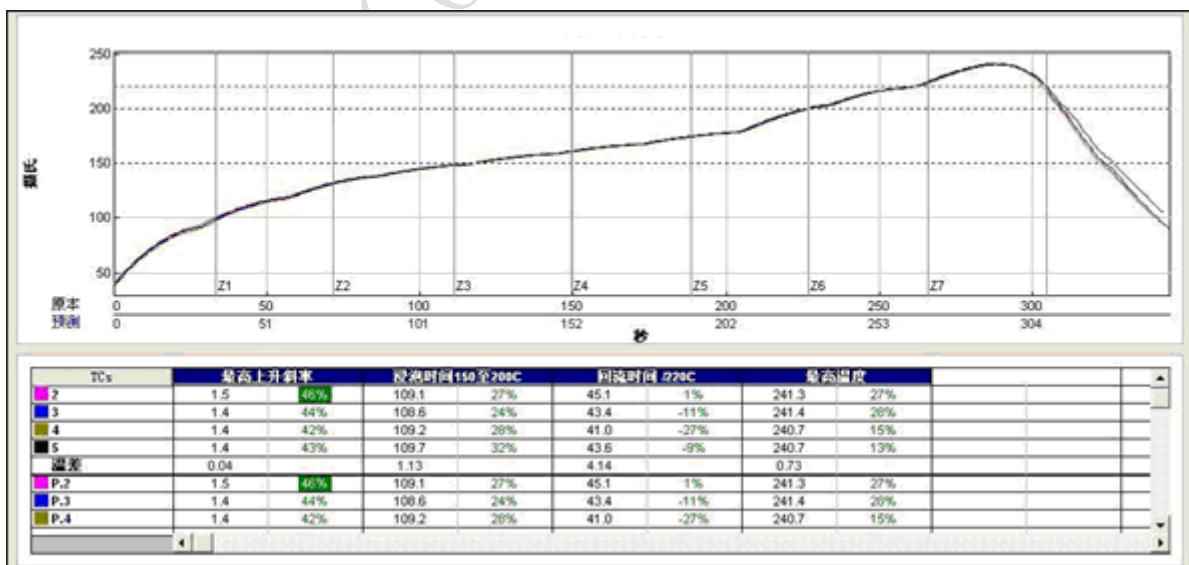

Figure 10: The Ramp-Soak-Spike reflow profile of SIM33EAU

SIM33EAU is Moisture Sensitive Devices (MSD), appropriate MSD handling instruction and precautions are summarized in Chapter 7.3.

SIM33EAU modules are also Electrostatic Sensitive Devices (ESD), handling SIM33EAU modules without proper ESD protection may destroy or damage them permanently.

Avoid ultrasonic exposure due to internal crystal and SAW components.

7.3 Moisture sensitivity

SIM33EAU module is moisture sensitive at MSL level 3, dry packed according to IPC/JEDEC specification J-STD-020C. The calculated shelf life for dry packed SMD packages is a minimum of 12 months from the bag seal date, when stored in a non condensing atmospheric environment of <40 °C/90% RH.

Table 12 lists floor life for different MSL levels in the IPC/JDEC specification:

Table 12: Moisture Classification Level and Floor Life

Level	Floor Life(out of bag)at factory ambient $\leq +30^{\circ}\text{C}/60\% \text{RH}$ or as stated
1	Unlimited at $\leq +30^{\circ}\text{C}/85\% \text{RH}$
2	1 year
2a	4 weeks
3	168 hours
4	72 hours
5	48 hours
5a	24 hours
6	Mandatory bake before use. After bake, module must be reflowed within the time limit specified on the label.

Factory floor life is 1 week for MSL 3, SIM33EAU must be processed and soldered within the time. If this time is exceeded, the devices need to be pre-baked before the reflow solder process.

Both encapsulate and substrate materials absorb moisture. IPC/JEDEC specification J-STD-020 must be observed to prevent cracking and delamination associated with the "popcorn" effect during reflow soldering. The popcorn effect can be described as miniature explosions of evaporating moisture. Baking before processing is required in the following case:

- Floor life or environmental requirements after opening the seal have been exceeded, e.g. exposure to excessive seasonal humidity.

Refer to Section 4 of IPC/JEDEC J-STD-033 for recommended baking procedures.

Notes: Oxidation Risk: Baking SMD packages may cause oxidation and/or inter metallic growth of the terminations, which if excessive can result in solder ability problems during board assembly. The temperature and time for baking SMD packages are therefore limited by solder ability considerations. The cumulative bake time at a temperature greater than 90 °C and up to 125 °C shall not exceed 96 hours.

7.4 ESD handling precautions

SIM33EAU modules are Electrostatic Sensitive Devices (ESD). Observe precautions for handling!

Failure to observe these precautions can result in severe damage to the GNSS receiver!



GNSS receivers are Electrostatic Sensitive Devices (ESD) and require special precautions when handling. Particular care must be exercised when handling patch antennas, due to the risk of electrostatic charges. In addition to standard ESD safety practices, the following measures should be taken into account whenever handling the receiver:

Unless there is a galvanic coupling between the local GND (i.e. the work Table) and the PCB GND, then the first point of contact when handling the PCB shall always be between the local GND and PCB GND.

Before mounting an antenna patch, connect ground of the device

When handling the RF pin, do not come into contact with any charged capacitors and be careful when contacting materials that can develop charges (e.g. patch antenna ~10pF, coax cable ~50-80pF/m, soldering iron, ...)

To prevent electrostatic discharge through the RF input, do not touch the mounted patch antenna.

When soldering RF connectors and patch antennas to the receiver's RF pin, the user must make sure to use an ESD safe soldering iron (tip).

7.5 Shipment

SIM33EAU is designed and packaged to be processed in an automatic assembly line, and it is now packaged in SIM33EAU tray.

SIMCOM CONFIDENTIAL FILE

8 Reference Design

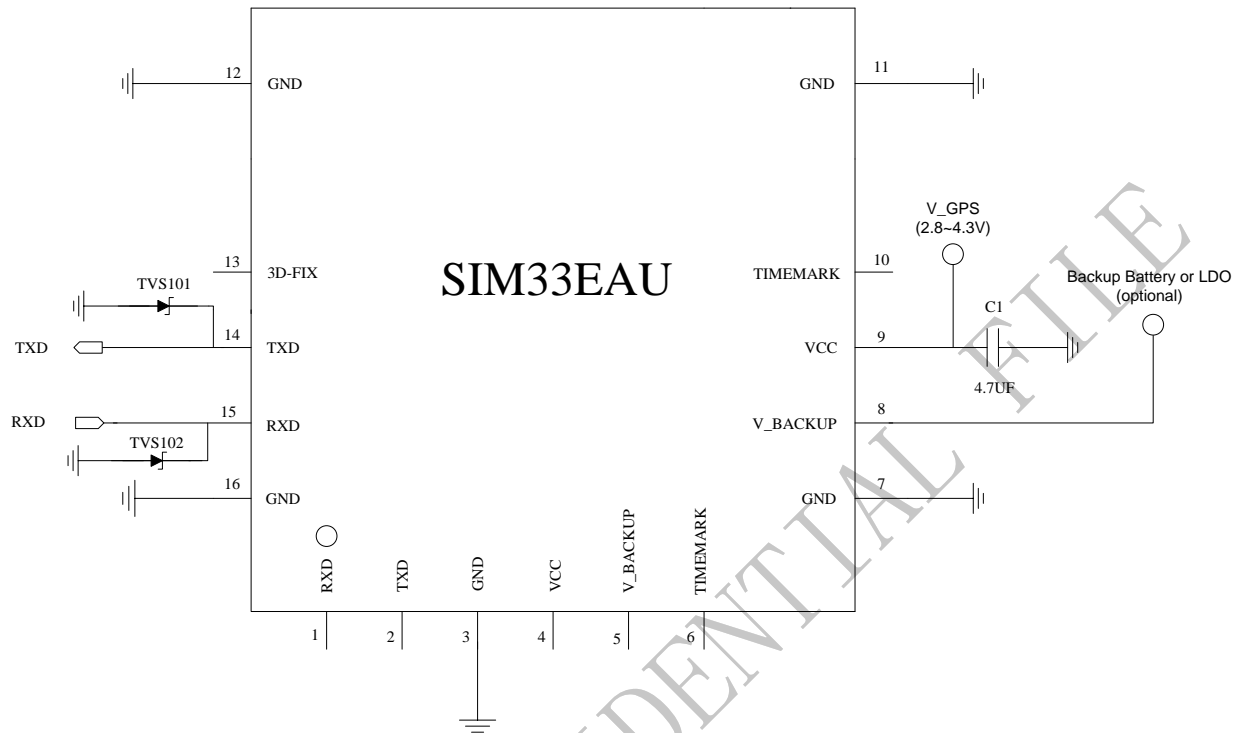

Figure 11: Example application schematic with UART

Appendix

A. Related Documents

Table 7: Related documents

SN	Document name	Remark
[1]	MT3333 Platform NMEA Message Specification_V1.01	
[2]	EPO-II_Format_Protocol_Customer	EPO-II_Format and Protocol

B. Terms and Abbreviations

Table 8: Terms and abbreviations

Abbreviation	Description
A-GPS	Assisted Global Positioning System
CMOS	Complementary Metal Oxide Semiconductor
CEP	Circular Error Probable
DGPS	Difference Global Positioning System
EEPROM	Electrically Erasable Programmable Read Only Memory
EPO	Extended Prediction Orbit
ESD	Electrostatic Sensitive Devices
EASY	Embedded Assist System
EGNOS	European Geostationary Navigation Overlay Service
GPS	Global Positioning System
GAGAN	The GPS Aided Geo Augmented Navigation
I/O	Input/Output
IC	Integrated Circuit
Inorm	Normal Current
Imax	Maximum Load Current
kbps	Kilo bits per second
MSL	moisture sensitive level
MSAS	Multi-Functional Satellite Augmentation System
NMEA	National Marine Electronics Association
PRN	Pseudo Random Noise Code
QZSS	Quasi-Zenith Satellites System
SBAS	Satellite Based Augmentation Systems
WAAS	Wide Area Augmentation System

Contact us:**Shanghai SIMCom Wireless Solutions Ltd.**

Add: SIM Technology Building, No.633, Jinzhong Road, Changning District, Shanghai P.R. China
200335

Tel: +86 21 3235 3300

Fax: +86 21 3235 3301

URL: www.sim.com/wm

SIMCOM CONFIDENTIAL FILE