

MATERIALS AND FINISHES:

FAKRA JACK:

BODY: ZINC ALLOY
FINISH: NICKEL

CRIMP TUBE: BRASS
FINISH: NICKEL

CENTER CONTACT: BRASS
FINISH: GOLD

INSULATOR: TEFLON

SHROUD: HIGH TEMP PLASTIC
COLOR: BORDEAUX VIOLET

CABLE: RG-174

SMB JACK
FAKRA CODE D
73404-1423

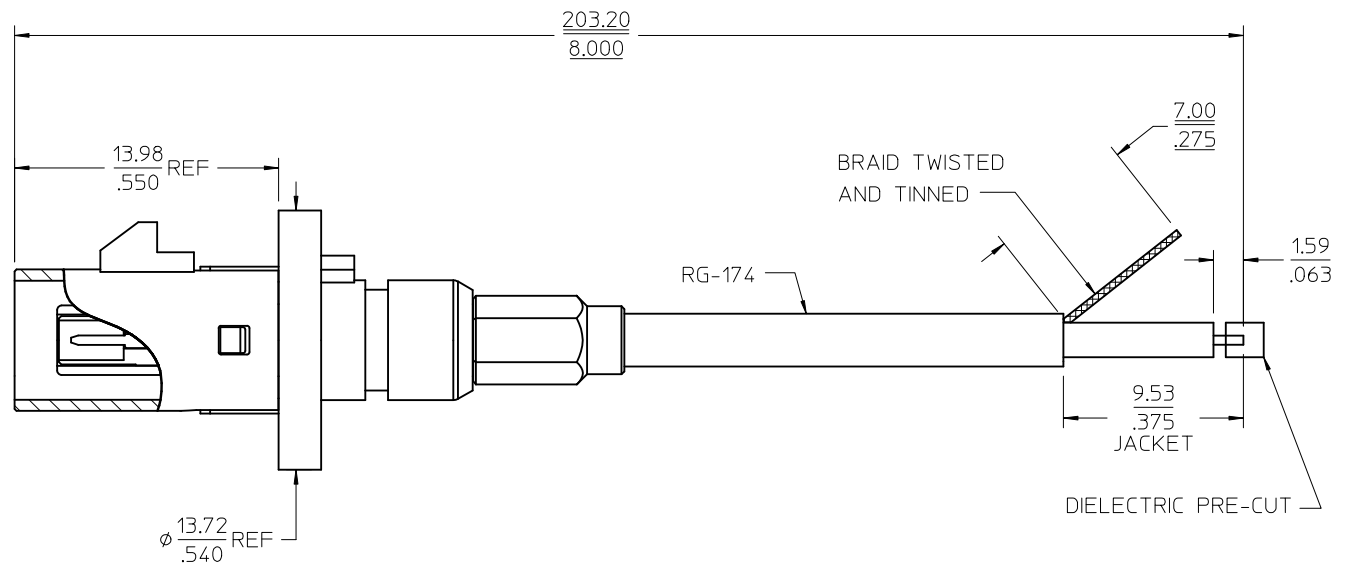
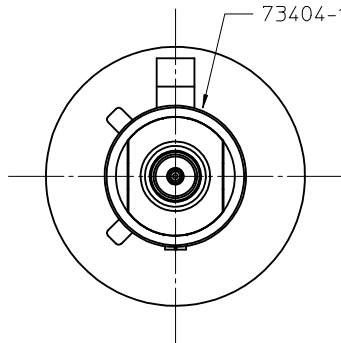

PART # 89762-0070

CHG: 7.00 WAS 7.94;
DIELECTRIC PRE-CUT
NOTE ADDED;

EC NO: URF2012-0238
DRWN:JLEE02 2011/11/02
CHKD:SSS 2011/11/02
APPR:WIENER 2011/11/02

DESCRIPTION

QUALITY SYMBOLS
▽=0
▽=0

GENERAL TOLERANCES (UNLESS SPECIFIED)

	mm	INCH
4 PLACES	± .---	± .---
3 PLACES	± .---	± .---
2 PLACES	± .---	± .---
1 PLACE	± .---	± .---

ANGULAR ± 2 °

DRAFT WHERE APPLICABLE
MUST REMAIN
WITHIN DIMENSIONS

DIMENSION STYLE
MM/IN

DRAWN BY DATE
JLEE02 2011/10/19
CHECKED BY DATE
SSS 2011/10/19
APPROVED BY DATE
JWIENER 2011/10/26

MATERIAL NO.

897620070

SCALE

DESIGN UNITS
METRIC

THIRD ANGLE PROJECTION

CA, SMB JACK, FAKRA
PIGTAIL, RG174, EWR-4811
CA-FAKRA/PIGTAIL



MOLEX INCORPORATED

DOCUMENT NO.

SD-89762-007

SHEET NO.

1 OF 1

SIZE
C

THIS DRAWING CONTAINS INFORMATION THAT IS PROPRIETARY TO MOLEX INCORPORATED AND SHOULD NOT BE USED WITHOUT WRITTEN PERMISSION