

MATERIALS AND FINISHES

N JACK (IP68)

BODY BRASS
PLATED NICKEL

CENTER CONTACT PHOSPHOR BRONZE
PLATED GOLD

INSULATOR TEFLON

GASKET SILICONE RUBBER

WASHER PHOSPHOR BRONZE
PLATED NICKEL

NUT BRASS
PLATED NICKEL

LABEL RPS OR EQUIVALENT

UFL CONNECTOR

BODY PHOSPHOR BRONZE
PLATED GOLD

CENTER CONTACT PHOSPHOR BRONZE
PLATED GOLD

HOUSING
PBT

CABLE

1.32 CABLE OR EQUIVALENT

SHRINK TUBE
ATUM

PACKAGING BY POLYBAG

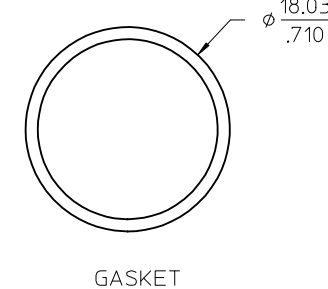
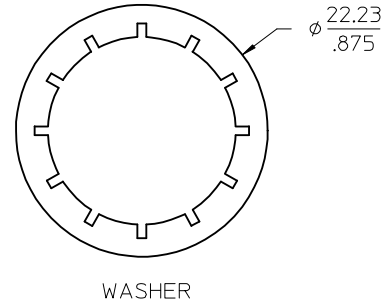
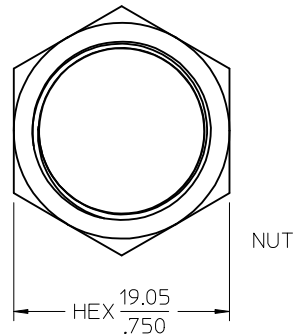
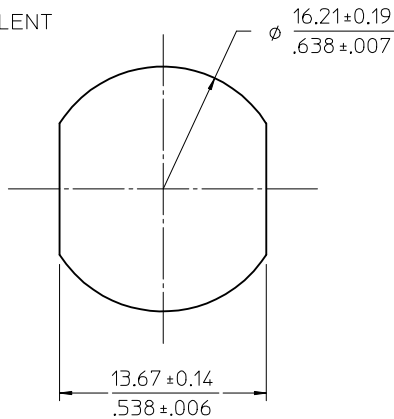
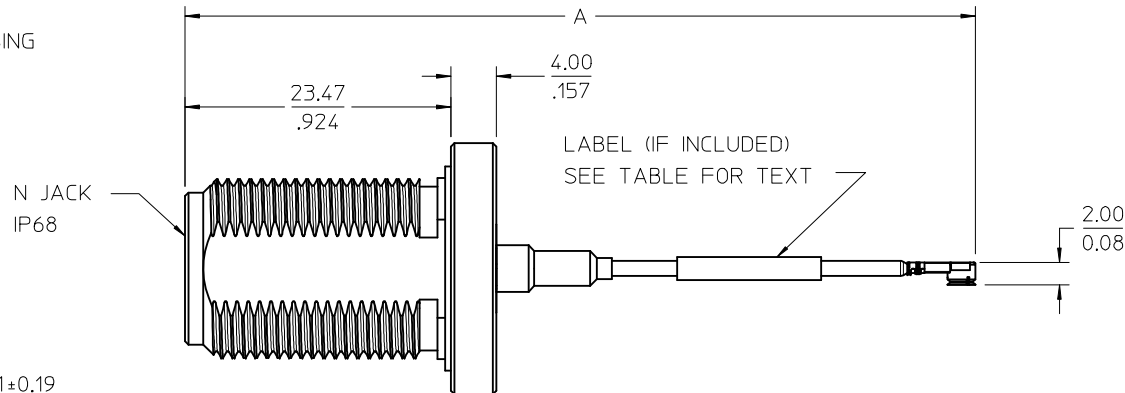
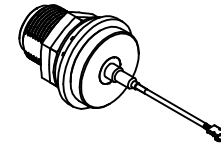

MAX. PANEL THICKNESS: 8.51 (.335)
RECOMMENDED MOUNTING TORQUE: 2.26N-M (20IN-LBS)

89761-1956	10.00±.250	254.00±6.35	N/A
89761-1955	6.00±.197	152.4±5.00	03-4479A02 REV B
89761-1954	9.00±.197	228.6±5.00	03-4479A03 REV B
89761-1953	6.00±.197	152.4±5.00	N/A
89761-1952	3.00±.197	76.2±5.00	03-4479A01 REV B
89761-1951	7.087±.197	180.00±5.00	N/A
89761-1950	9.843±.197	250.00±5.00	N/A
PART NO.	IN	MM	LABEL TEXT
A			

CHG: -1956	2013/09/10	QUALITY SYMBOLS
ADD: -1956	2013/09/11	▽=0
DRWN: JWIENER	2013/09/11	▽=0
CHKD: ROBERTSON	2013/09/11	DESCRIPTION
APPR: JWIENER	2013/09/11	REV
C1		

GENERAL TOLERANCES (UNLESS SPECIFIED)

	mm	INCH
4 PLACES	± .005	± .0005
3 PLACES	± .003	± .0003
2 PLACES	± .002	± .0002
1 PLACE	± .001	± .0001
ANGULAR ± 2 °		

DRAFT WHERE APPLICABLE
MUST REMAIN WITHIN DIMENSIONS

DIMENSION STYLE	
MM/IN	
DRAWN BY	DATE
JOYCE	2006/11/23
CHECKED BY	DATE
KERRIE	2006/11/23
APPROVED BY	DATE
MISEN	2006/11/23
MATERIAL NO.	DOCUMENT NO.
SEE TABLE	SD-89761-195
SIZE	
C	

SCALE	DESIGN UNITS	THIRD ANGLE PROJECTION
	METRIC	
TITLE		
CABLE ASSY N JACK TO UFL IP68 1.32 CABLE 50 OHMS RF10-E028 CA-N/UFL		
MOLEX INCORPORATED		
SHEET NO.		1 OF 1
THIS DRAWING CONTAINS INFORMATION THAT IS PROPRIETARY TO MOLEX INCORPORATED AND SHOULD NOT BE USED WITHOUT WRITTEN PERMISSION		