

REVISION/RECORD			
LTN	ECNO	APPROVED	DATE

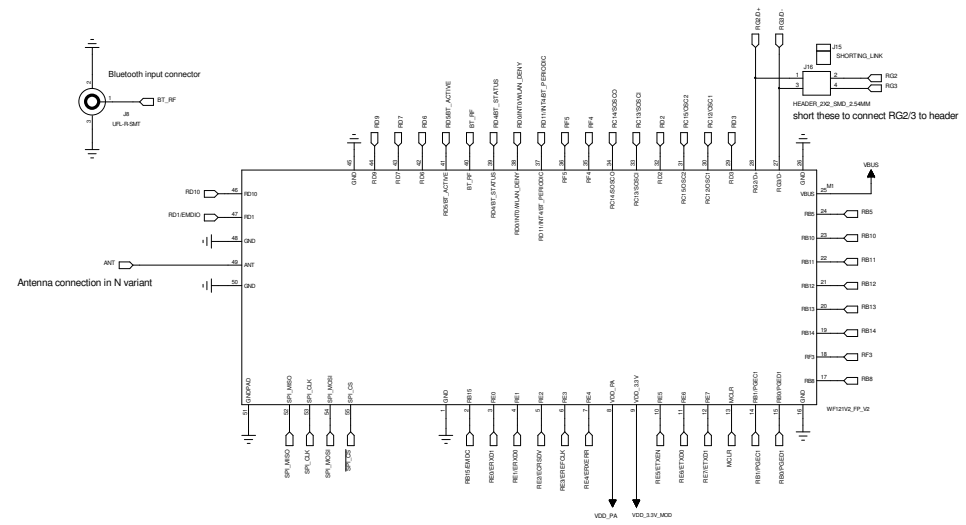
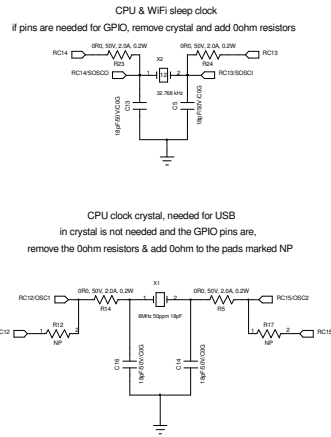

DRAWN		DATED		COMPANY:	
CHECKED		DATED		TITLE:	
QUALITY CONTROL		DATED		CODE:	SIZE:
RELEASED		DATED		DRAWING NO:	
SCALE:		SHEET: 9		REV:	

D

REVISION RECORD			
LTR	EDG NO.	APPROVED	DATE

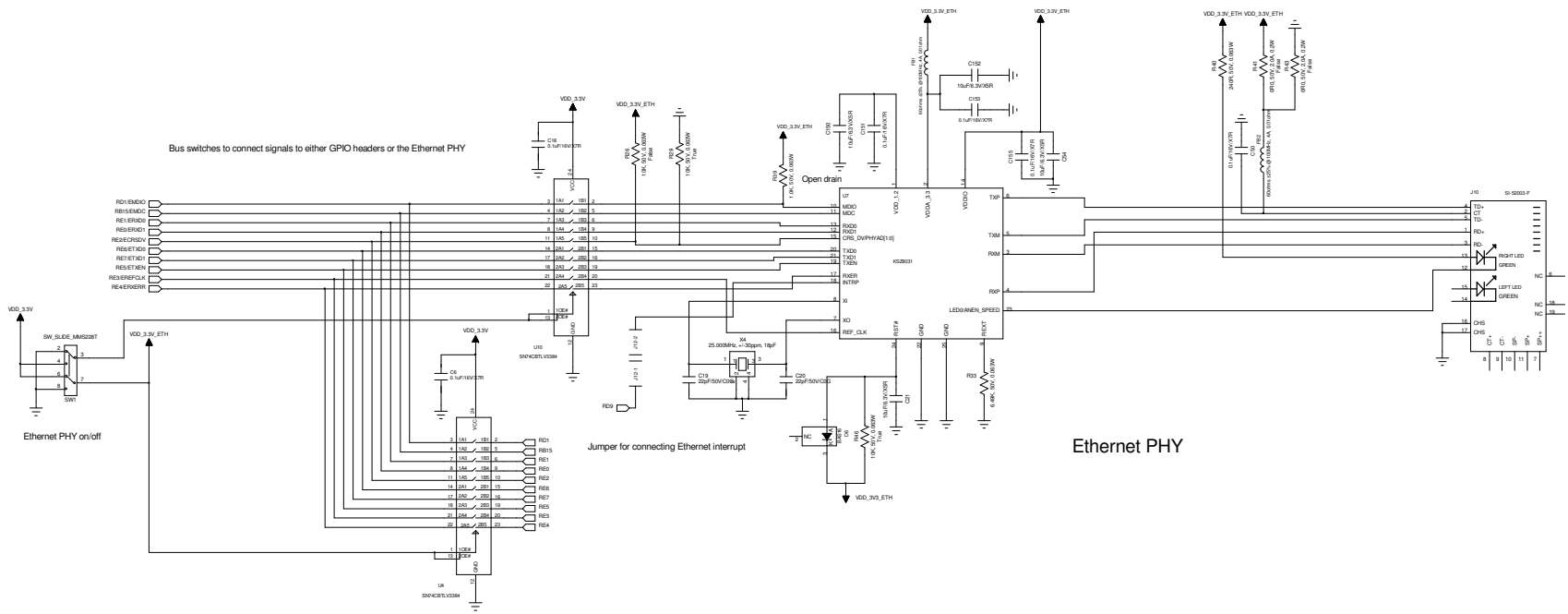

COMPANY:			
TITLE:			
DRAWN:	DATED:	CODE:	REV
CHECKED:	DATED:	SIZE:	DRAWING NO.
QUALITY CONTROL:	DATED:	D	
RELEASED:	DATED:	SCALE:	SHEET: 3 of 9

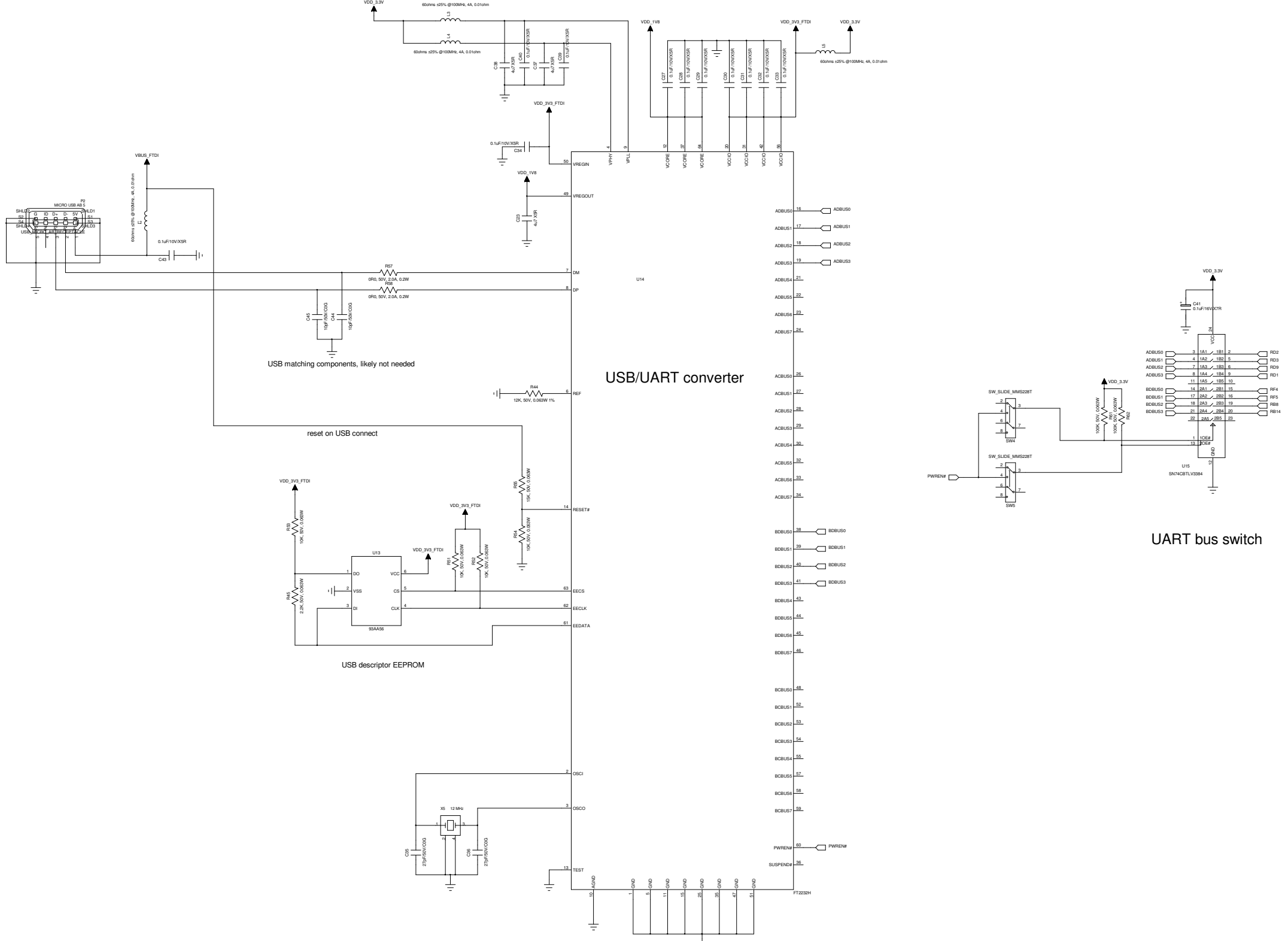

6

5

4

3

2

1

REVISION RECORD			
LTR	ECO NO.	APPROVED	DATE

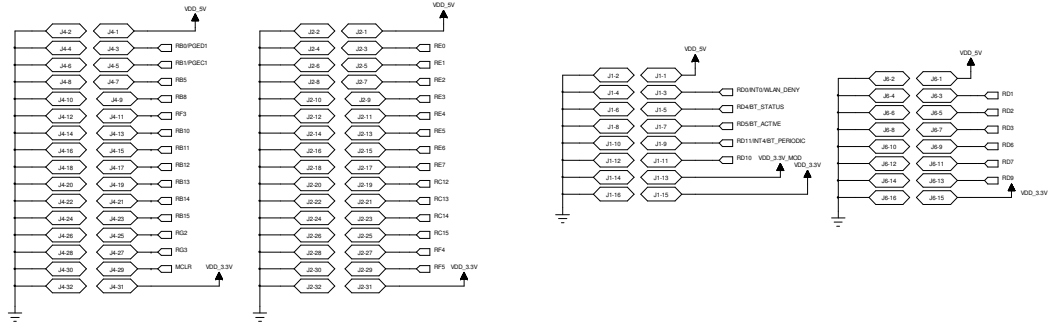

COMPANY:			
TITLE:			
DRAWN:	DATED:	CODE:	REV
CHECKED:	DATED:	SIZE:	DRAWING NO.
QUALITY CONTROL:	DATED:	<b>D</b>	
RELEASED:	DATED:		
SCALE:			SHEET: 5 of 9

REVISION RECORD			
LTR	ECO NO.	APPROVED	DATE

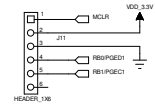

PicKit3 programming connector for module processor

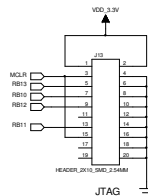

JTAG

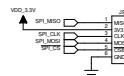

WiFi debug SPI

COMPANY:			
TITLE:			
CODE:	SIZE:	DRAWING NO:	REV:
<b>D</b>			

DRAWN:	DATED:
CHECKED:	DATED:
QUALITY CONTROL:	DATED:
RELEASED:	DATED:

REVISION RECORD			
LTR	ECO NO.	APPROVED	DATE

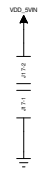

external 5V nominal power supply  
 this supply can range between 2.7-5.5V  
 except when USB-OTG is used in host mode  
 which requires a 5V supply

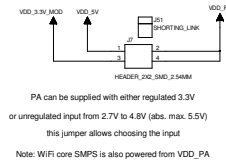
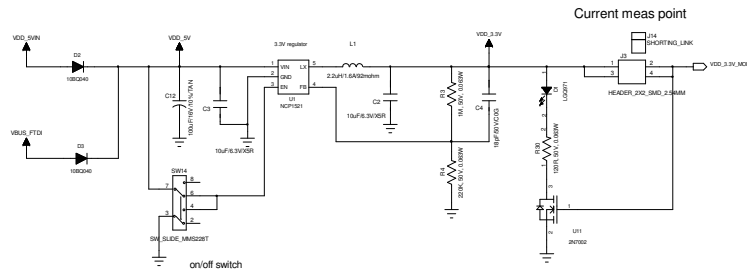

PA can be supplied with either regulated 3.3V  
 or unregulated input from 2.7V to 4.8V (abs. max. 5.5V)  
 this jumper allows choosing the input  
 Note: WIFI core SMPS is also powered from VDD\_PA

COMPANY:			
TITLE:			
DRAWN:	DATED:	CODE:	REV
CHECKED:	DATED:	SIZE:	DRAWING NO.
QUALITY CONTROL:	DATED:	<b>D</b>	
RELEASED:	DATED:	SCALE:	SHEET: 2 of 9

6

5

4

3

2

1

REVISION RECORD			
LTR	ECO NO.	APPROVED	DATE

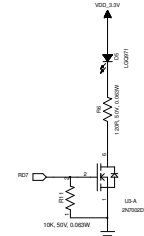
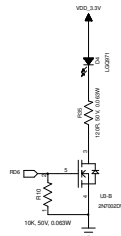
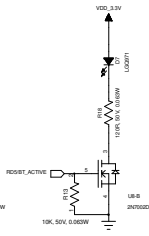
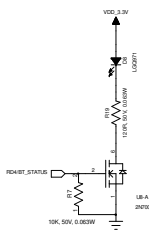
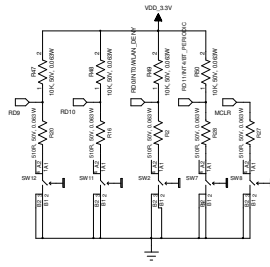

DRAWN:		DATED:		COMPANY:			
CHECKED:		DATED:		TITLE:			
QUALITY CONTROL:		DATED:		CODE:	SIZE:	DRAWING NO.:	REV:
RELEASED:		DATED:		<b>D</b>			
SCALE:				SHEET: 8 of 9			

REVISION RECORD			
LTR	ECO NO.	APPROVED	DATE

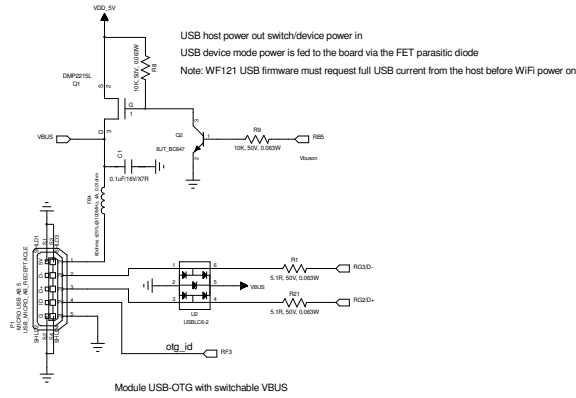

DRAWN:		DATED:		COMPANY:			
CHECKED:		DATED:		TITLE:			
QUALITY CONTROL:		DATED:		CODE:	SIZE:	DRAWING NO.:	REV:
RELEASED:		DATED:		<b>D</b>			
SCALE:				SHEET: 9 of 9			