

Rayson

Bluetooth® Module

Class2 BC04-ext mini Module

BTM-160/170

Features

- The module is a Max.4dBm(Class2) module.
- *Bluetooth* standard Ver. 2.0 + EDR compliant.
- Low current consumption :
Hold,Sniff,Park,Deep sleep Mode
- 3.0V or 1.8V operation
- Support for up to seven slaves :
SCO links<3>,ACL links,Piconet<7>
- Interface: USB,UART&PCM(for voice CODEC)
- HCI or SPP,HSP/HFP,HID firmware is available
- Support for 802.11 Co-Exsitence
- RoHS compliant
- Small outline. 14 x 12 x 2.2 mm

Applications

- PDA
- Cordless headset
- Digital camera & printer
- Access Points
- GPS,POS, Barcode Reader
- Domestic and industrial applications

Outline



General Electrical Specification

Parameter	Description	Min.	Typ.	Max.	Units
Operating Voltage	VDD (BTM160)	3.00	3.30	3.60	V
	VDD (BTM170)	1.70	1.8	1.9	V
RF Output Power	Measured in 50 ohm	0	2	4	dBm
RX Sensitivity			-83	-80	dBm
Input Low Voltage	RESET,UART,GPIO,PCM	-0.30	-	0.80	V
Input High Voltage	RESET,UART,GPIO,PCM	0.70VDD	-	VDD+0.30	V
Output Low Voltage	UART,GPIO,PCM	-	-	0.40	V
Output High Voltage	UART,GPIO,PCM	VDD-0.40	-	-	V
Average Current Consumption	Deep sleep		40		uA
	ACL 40ms sniff		2.4		mA
	SCO connection HV1		39	-	mA
Peak Current	Tx burst +4dBm		-	58	mA

Block Diagram

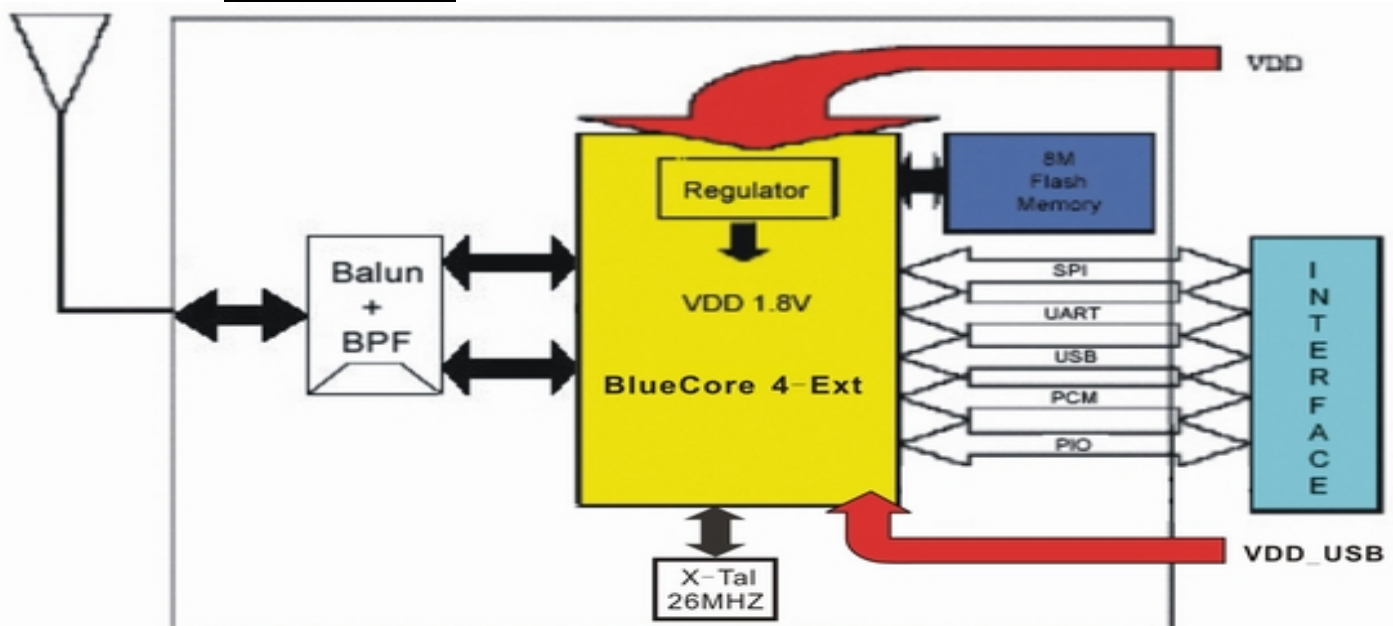

Radio Characteristics – Basic Data Rate

Radio Characteristics, VDD = 3.3V Temperature =+20°C						
	Frequency (GHz)	Min	Typ	Max	Bluetooth Specification	Unit
Sensitivity at 0.1% BER	2.402	-	-83	-82	≤ -70	dBm
	2.441	-	-83	-82		dBm
	2.480	-	-83	-82		dBm
Maximum received signal at 0.1% BER	2.402	-	-6	0	≥ -20	dBm
	2.441	-	-6	0		dBm
	2.480	-	-6	0		dBm
RF transmit power ⁽¹⁾	2.402	-	+2	-	-6 to +4 ⁽²⁾	dBm
	2.441	-	+2	-		dBm
	2.480	-	+2	-		dBm
Initial carrier frequency tolerance	2.402	-	12	20	± 75	kHz
	2.441	-	10	20		kHz
	2.480	-	9	20		kHz
20dBm bandwidth for modulated carrier	2.402	-	879	1000	≤ 1000	kHz
	2.441	-	816	1000		kHz
	2.480	-	819	1000		kHz
Drift (single slot packet)	2.402	-	-	20	≤ 25	kHz
	2.441	-	-	20		kHz
	2.480	-	-	20		kHz
Drift (five slot packet)	2.402	-	-	20	≤ 40	kHz
	2.441	-	-	20		kHz
	2.480	-	-	20		kHz
Drift Rate	2.402	-	-	15	20	kHz/50 μ s
	2.441	-	-	15		kHz/50 μ s
	2.480	-	-	15		kHz/50 μ s
RF power control range		16	35	-	≥ 16	dB
RF power range control resolution		-	1.8	-	-	dB
$\Delta f1^{avg}$ "Maximum Modulation"	2.402	145	165	175	$140 < \Delta f1^{avg} < 175$	kHz
	2.441	145	165	175		kHz
	2.480	145	165	175		kHz
$\Delta f2^{maz}$ "Minimum Modulation"	2.402	115	150	-	115	kHz
	2.441	115	150	-		kHz
	2.480	115	150	-		kHz
C/I co-channel		-	10	11	≤ 11	dB
Adjacent channel selectivity C/I $F=F_0+1\text{ MHz}^{(3)(5)}$		-	-4	0	≤ 0	dB
Adjacent channel selectivity C/I $F=F_0-1\text{ MHz}^{(3)(5)}$		-	-4	0	≤ 0	dB
Adjacent channel selectivity C/I $F=F_0+2\text{ MHz}^{(3)(5)}$		-	-35	-30	≤ -30	dB
Adjacent channel selectivity C/I $F=F_0-2\text{ MHz}^{(3)(5)}$		-	-21	-20	≤ -20	dB
Adjacent channel selectivity C/I $F \geq F_0+3\text{ MHz}^{(3)(5)}$		-	-45	-	≤ -40	dB
Adjacent channel selectivity C/I $F \leq F_0-5\text{ MHz}^{(3)(5)}$		-	-45	-	≤ -40	dB
Adjacent channel selectivity C/I $F=F_{image}^{(3)(5)}$		-	-18	-9	≤ -9	dB
Adjacent channel transmit power $F=F_0 \pm 2\text{ MHz}^{(4)(5)}$		-	-35	-20	≤ -20	dBc
Adjacent channel transmit power $F=F_0 \pm 3\text{ MHz}^{(4)(5)}$		-	-55	-40	≤ -40	dBc

Notes:

- (1) BlueCore-External firmware maintains the transmit power to be within the Bluetooth specification v2.0 limits.
- (2) Class 2 RF transmit power range, Bluetooth specification v2.0
- (3) Up to five exceptions are allowed in v2.0 of the Bluetooth specification
- (4) Up to three exceptions are allowed in v2.0 of the Bluetooth specification

⁽⁵⁾ Measured at $F_0 = 2441\text{MHz}$

Radio Characteristics – Enhanced Data Rate

Transmitter , VDD = 3.3V Temperature =+20°C						
	Frequency (GHz)	Min.	Typ.	Max.	Bluetooth Specification	Unit
Maximum RF transmit power	2.402	-6	0	+2	-6 to +20	dBm
	2.441	-6	0	+2		dBm
	2.480	-6	0	+2		dBm
Relative transmit power		-	-1.5	-	-4 to +1	dB
$\pi/4$ DQPSK Maximum carrier frequency stability w_0		-	2	-	$\leq \pm 10$ for all blocks	kHz
$\pi/4$ DQPSK Maximum carrier frequency stability w_i		-	6	-	$\leq \pm 75$ for all packets	kHz
$\pi/4$ DQPSK Maximum carrier frequency stability $ w_0 + w_i $		-	8	-	$\leq \pm 75$ for all blocks	kHz
8 DPSK Maximum carrier frequency stability w_0		-	2	-	$\leq \pm 10$ for all blocks	kHz
8 DPSK Maximum carrier frequency stability w_i		-	6	-	$\leq \pm 75$ for all packets	kHz
8 DPSK Maximum carrier frequency stability $ w_0 + w_i $		-	8	-	$\leq \pm 75$ for all blocks	kHz
$\pi/4$ DQPSK Modulation Accuracy	RMS DVEM	-	7	-	≤ 20	%
	99% DEVM	-	13	-	≤ 30	%
	Peak DEVM	-	19	-	≤ 35	%
8 DPSK Modulation Accuracy	RMS DVEM	-	7	-	≤ 13	%
	99% DEVM	-	13	-	≤ 20	%
	Peak DEVM	-	17	-	≤ 25	%
In-band spurious emissions	$F > F_0 + 3\text{ MHz}$	-	< -50	-	≤ -40	dBm
	$F < F_0 - 3\text{ MHz}$	-	< -50	-	≤ -40	dBm
	$F = F_0 - 3\text{ MHz}$	-	-46	-	≤ -40	dBm
	$F = F_0 - 2\text{ MHz}$	-	-34	-	≤ -20	dBm
	$F = F_0 - 1\text{ MHz}$	-	-35	-	≤ -26	dBm
	$F = F_0 + 1\text{ MHz}$	-	-35	-	≤ -26	dBm
	$F = F_0 + 2\text{ MHz}$	-	-31	-	≤ -20	dBm
	$F = F_0 + 3\text{ MHz}$	-	-33	-	≤ -40	dBm
EDR Differential Phase Encoding			No Errors		≥ 99	%
Receiver , VDD = 3.3V Temperature =+20°C						
	Modulation	Min.	Typ.	Max.	Bluetooth Specification	Unit
Sensitivity at 0.1% BER	$\pi/4$ DQPSK	-	-82	-	≤ -70	dBm
	8 DPSK	-	-76	-	≤ -70	dBm
Maximum received signal level at 0.1% BER	$\pi/4$ DQPSK	-	-8	-	≥ -20	dBm
	8 DPSK	-	-10	-	≥ -20	dBm
C/I co-channel at 0.1% BER	$\pi/4$ DQPSK	-	10	-	$\leq +13$	dB
	8 DPSK	-	19	-	$\leq +21$	dB
Adjacent channel selectivity C/I $F = F_0 + 1\text{ MHz}$	$\pi/4$ DQPSK	-	-10	-	≤ 0	dB
	8 DPSK	-	-5	-	$\leq +5$	dB
Adjacent channel selectivity C/I $F = F_0 - 1\text{ MHz}$	$\pi/4$ DQPSK	-	-11	-	≤ 0	dB
	8 DPSK	-	-5	-	$\leq +5$	dB
Adjacent channel selectivity C/I $F = F_0 + 2\text{ MHz}$	$\pi/4$ DQPSK	-	-40	-	≤ -30	dB
	8 DPSK	-	-40	-	≤ -25	dB

Adjacent channel selectivity C/I F=F ₀ -2 MHz	$\pi/4$ DQPSK	-	-23	-	≤ -20	dB
	8 DPSK	-	-20	-	≤ -13	dB
Adjacent channel selectivity C/I F=F ₀ +3 MHz	$\pi/4$ DQPSK	-	-45	-	≤ -40	dB
	8 DPSK	-	-45	-	≤ -33	dB
Adjacent channel selectivity C/I F=F ₀ -5 MHz	$\pi/4$ DQPSK	-	-45	-	≤ -40	dB
	8 DPSK	-	-45	-	≤ -33	dB
F ₀ = 2405, 2441, 2477 MHz						
Adjacent channel selectivity C/I F=F _{image}	$\pi/4$ DQPSK		-20		≤ -7	dB
	8 DPSK		-15		≤ 0	dB

BTM-160/170 Pins out Information

PIN	NAME	TYPE	FUNCTION
1	GND	GND	Ground
2	RF_IO	Analogue	Antenna Interface
3	GND	GND	Ground
4	PIO(11)	Bi-directional	Programmable Input/Output line
5	PIO(10)	Bi-directional	Programmable Input/Output line
6	PIO(9)	Bi-directional	Programmable Input/Output line
7	PIO(8)	Bi-directional	Programmable Input/Output line
8	PIO(2)	Bi-directional	Programmable Input/Output line
9	AIO(1)	Bi-directional	Programmable Input/Output Line
10	GND	GND	Ground
11	VDD	Power	3.3V or 1.8V Power Supply Input
12	AIO(0)	Bi-directional	Programmable Input/Output Line , 32KHz sleep clock input
13	UART_TX	CMOS Input	UART Data Output
14	UART_RTS	CMOS Output	UART Request To Send (Active Low)
15	UART_RX	CMOS Output	UART Data Input
16	UART_CTS	CMOS Input	UART Clear To Send (Active Low)
17	USB_DP	Bi-directional	USB Data Plus
18	USB_DN	Bi-directional	USB Data Minus
19	PCM_CLK	Bi-directional	Synchronous Data Clock
20	PCM_IN	CMOS Input	Synchronous Data Input
21	PCM_OUT	CMOS Output	Synchronous Data Output
22	PCM_SYNC	Bi-directional	Synchronous Data Sync
23	VDD_USB	Power	3.3V Power Supply Input
24	PIO(7)	Bi-directional	Programmable Input/Output line
25	PIO(6)	Bi-directional	Programmable Input/Output line , CLK_REQ , WLAN_Ative/Ch_Data input
26	PIO(5)	Bi-directional	Programmable Input/Output line , USB_DETACH, BT_Ative output
27	PIO(4)	Bi-directional	Programmable Input / Output Line , USB_ON, BT_Priority/Ch_Clk Output
28	GND	GND	Ground
29	RESETB	CMOS input	Reset if low. Input debounced so must be low for >5ms to cause a reset
30	SPI_CSB	CMOS Input	Chip Select For Synchronous Serial Interface active low
31	SPI_MISO	CMOS Output	Serial Peripheral Interface Data Output
32	SPI_MOSI	CMOS Input	Serial Peripheral Interface Data Input
33	SPI_CLK	CMOS Input	Serial Peripheral Interface Clock
34	PIO(3)	Bi-directional	Programmable Input/Output Line , USB_WAKE_UP, CLK_REQ_IN
35	PIO(1)	Bi-directional	Programmable Input/Output Line , TX Enable
36	PIO(0)	Bi-directional	Programmable Input / Output Line , RX Enable

Dimension

Unit:mm

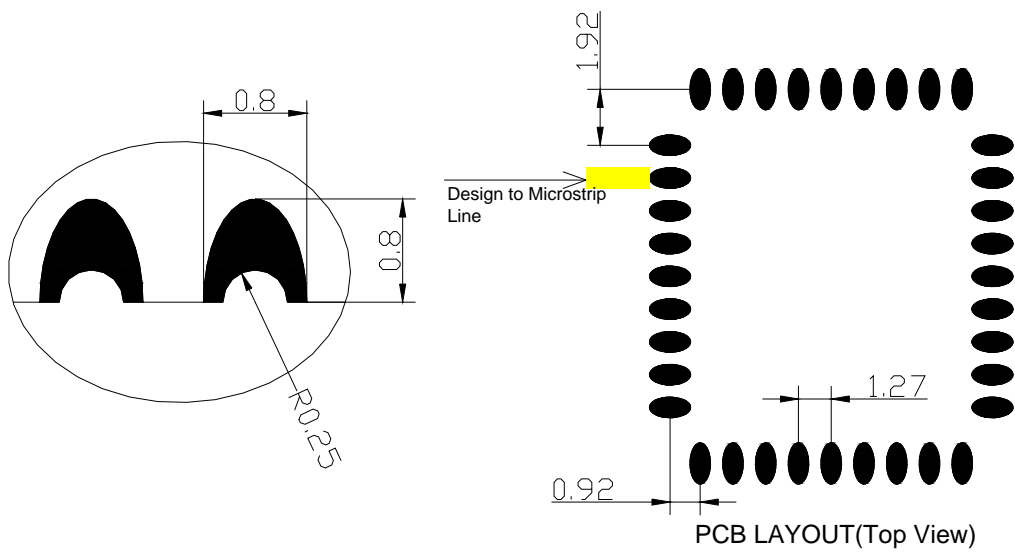
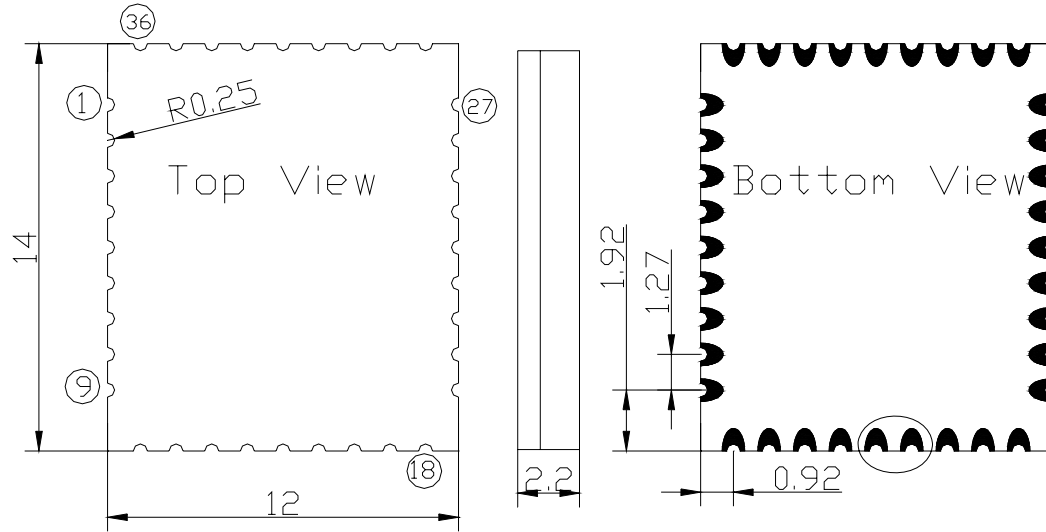

PCB LAYOUT(Top View)