

# AWGM1xxxxxxxxxx

## 100G Arrayed-Waveguide Grating Multiplexer/Demultiplexer



Arrayed-Waveguide Grating (AWG) multiplexers and demultiplexers combine or split optical signals of different wavelengths (channels) in DWDM systems.

Molex's planar lightwave circuits are well suited for demanding telecom applications in long-haul and metro transmission systems. The AWG offers low insertion loss, accurate channel alignment, very low crosstalk and high channel-to-channel uniformity. This product family complies with Telcordia GR-1221-CORE.



### Performance Specification

AWGM1 Parameters	Min.	Typical	Max.	Unit
Available Channel Frequency Range	191.85		196.20	THz
Channel Spacing		100		GHz
Number of Channels		32, 40 or 44		
Channel Passband		± 12.5		GHz
Insertion Loss <sup>[1]</sup>		5.0	6.0	dB
Uniformity		< 1.5		dB
Ripple		0.5	0.75	dB
Polarization Dependent Loss			0.5	dB
Adjacent Channel Crosstalk	25			dB
Non-adjacent Channel Crosstalk	35			dB
Total Crosstalk	22			dB
Return Loss	40			dB
Directivity	50			dB
Power Consumption		4		W
Maximum Power Handling			300	mW
Fiber Type		G. 652D		
Fiber Jacket		C : 900µm Tight Buffer B : 12-Core Ribbon Fiber A : 900µm Loose Tube		
Fiber Length		Refer Ordering Information		
Connector Type		Referr Ordering Information		
Package Type <sup>[2]</sup>		P3 : Internal Temperature Control P4 : Thermistor Temperature Sensor Only		
Operating Temperature		- 5 to +65		°C
Storage Temperature		-40 to +85		°C

Notes:

[1] The maximum IL is under all states of polarization and within the full operating temperature and wavelength ranges specified.

[2] Please contact Molex Sales, Marketing or PLM for more details about electrical specifications.

[3] All the parameters are excluding connectors. IL of connectors is 0.2dB/pair for PC/UPC/SPC types and 0.4dB per pair for APC types.

### Features

- ◆ Established Silica-on-Silicon Technology
- ◆ Extremely Low Crosstalk
- ◆ Low Insertion Loss
- ◆ Low PDL
- ◆ Low Chromatic Dispersion
- ◆ Telcordia GR-1221-CORE Qualified

### Applications

- ◆ DWDM Transmission
- ◆ Wavelength Routing
- ◆ Optical Add/Drop Multiplexing

### Options

- ◆ Channel Count: 32, 40 or 44
- ◆ RTD/Thermistor Temperature Sensor or Internal Temp Control Option

# AWGM1xxxxxxxxxx

100G Arrayed-Waveguide Grating  
Multiplexer/Demultiplexer



## Channel Spectrum Tables

Typical Gaussian  
40-Channel Spectrum

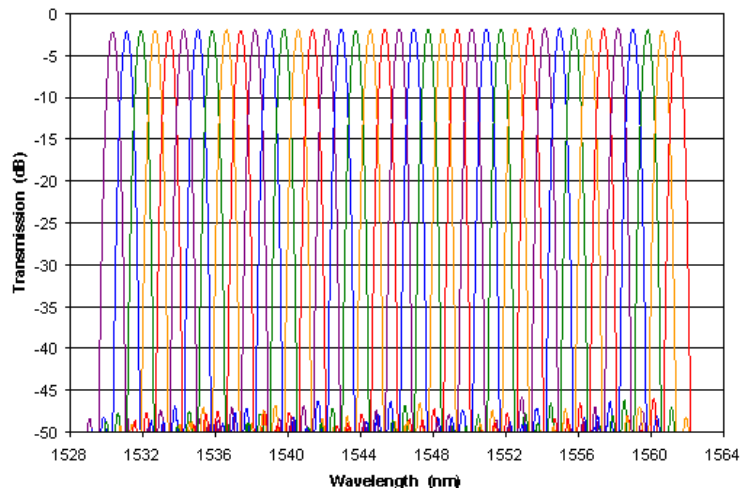

Typical Moderate  
40-Channel Spectrum

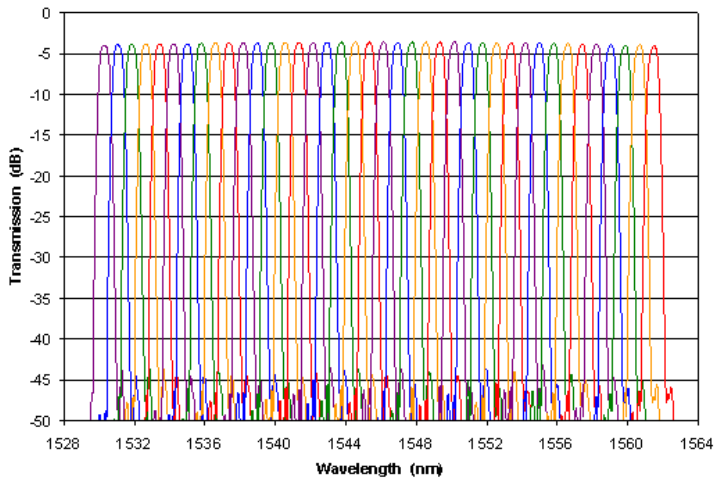

Typical Flat-Top  
40-Channel Spectrum

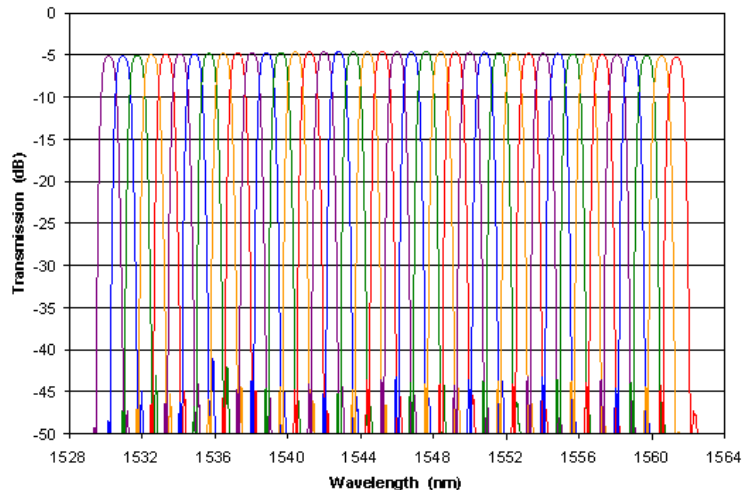

# AWGM1xxxxxxxxxx

100G Arrayed-Waveguide Grating  
Multiplexer/Demultiplexer



## Mechanical Drawing / Package Dimensions

P3/P4:

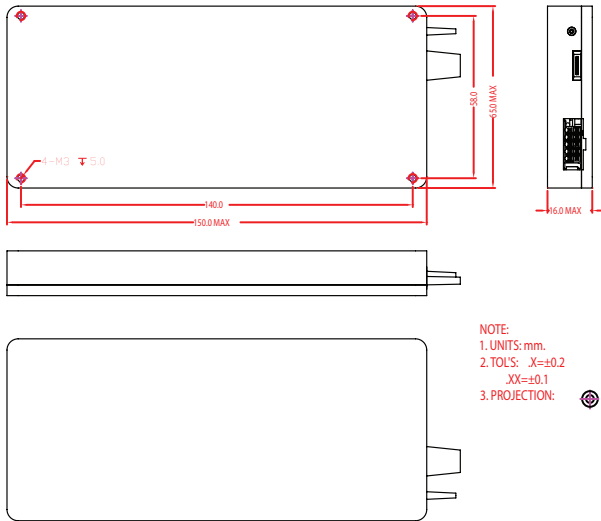

Definition of Fiber Length A, B and C:

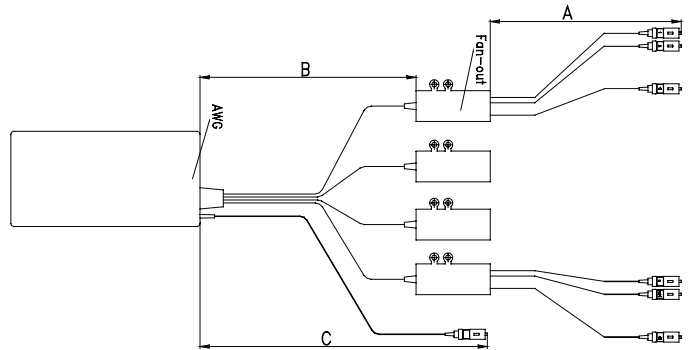

\*The mechanical tolerance should be ±0.2mm on all package dimensions unless otherwise specified.

## Ordering Information

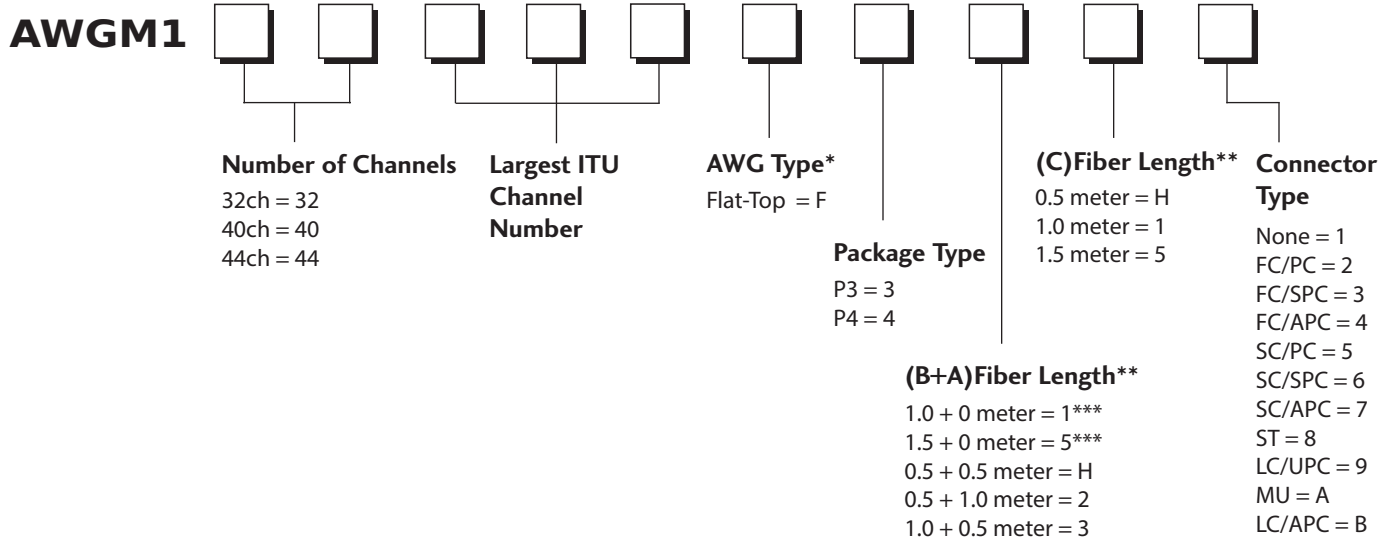

\* Gaussian and Moderate (Semi Flat-Top) types are available. Please contact Molex Sales and Marketing for details.

\*\* The tolerance of fiber length is ±0.1m.

\*\*\* Connectors are not available if the length of fiber A is 0. Please choose 1 for the last digit of Molex Part Number.

For example, AWGM140C60F3219 represents one 100G 40-ch (192.10~192.60THz) Flat-Top type AWG module with P3 package, 1.0±0.1m fiber length on fiber C, 0.5±0.1m fiber length on fiber B, 1.0±0.1m fiber length on fiber A and LC/UPC connectors.