

ACA-3216-A2-MC-S SPECIFICATION

1. EXPLANATION OF PART NUMBER :

$\frac{AC}{(1)}$ $\frac{A}{(2)}$ - $\frac{3216}{(3)}$ $\frac{A2}{(4)}$ - $\frac{MC}{(5)}$ - $\frac{S}{(6)}$ - $\bar{(7)}$

- (1) Product Type : Chip Antenna
- (2) Center Frequency/Band Code : A -2.45GHz
- (3) Size Code : 3.2mm(length) x 1.6mm(width)
- (4) Design Revision Code : A2= Rev. 2
- (5) Series No. : MC=MONOPOLE Ceramics type
- (6) Special Code : S= RoHS Compliant
- (7) Suffix For Special Requirements

2. ELECTRICAL SPECIFICATION :

ITEM	SPECIFICATION
Frequency Band	2400MHz~2500MHz
Return Loss	Less than -10
Polarization	Linear
*Gain	Max peak gain : 0.5 dBi
	Typ peak gain : -0.5 dBi
Impedance	50Ω typ.

*Test condition : Test board size 53*20 mm , ground clearance 13*20 mm
Matching circuit : Pi matching circuit will be required

3. DIMENSIONS :

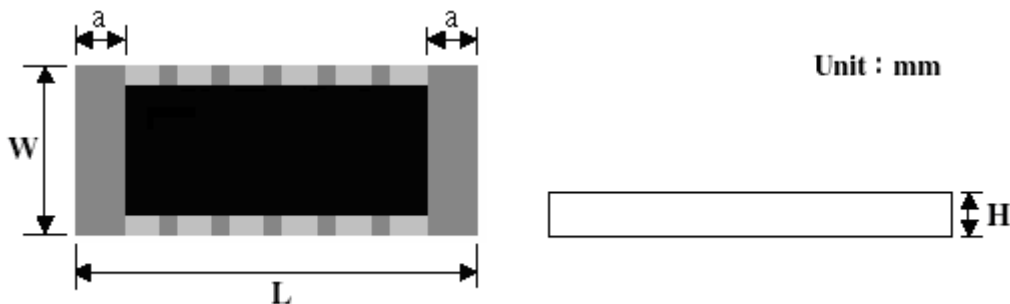

Mark	L	W	H	a
Dimensions	3.2±0.2	1.6±0.2	0.7±0.15	0.35±0.2

UNLESS OTHER SPECIFIED TOLERANCES ON :

X=± X.X=± X.XX=

ANGLES=± HOLEDIA=±

SCALE : xxxx UNIT : mm

DRAWN BY:彭少君 CHECKED BY:謝立庭

DESIGNED BY:彭少君 APPROVED BY:謝立庭



INPAQ TECHNOLOGY CO., LTD.

THIS DRAWINGS AND SPECIFICATIONS ARE THE PROPERTY OF INPAQ TECHNOLOGY CO.,LTD.AND SHALL NOT BE REPRODUCED OR USED AS THE BASIS FOR THE MANUFACTURE OR SALE OF APPARATUS OR DEVICES WITHOUT PERMISSION

TITLE : ACA-3216-A2-MC-S SPECIFICATION

DOCUMENT NO.

ENS000015380

SPEC REV.
A1

4. RECOMMENDED PCB LAYOUT : (unit : mm)

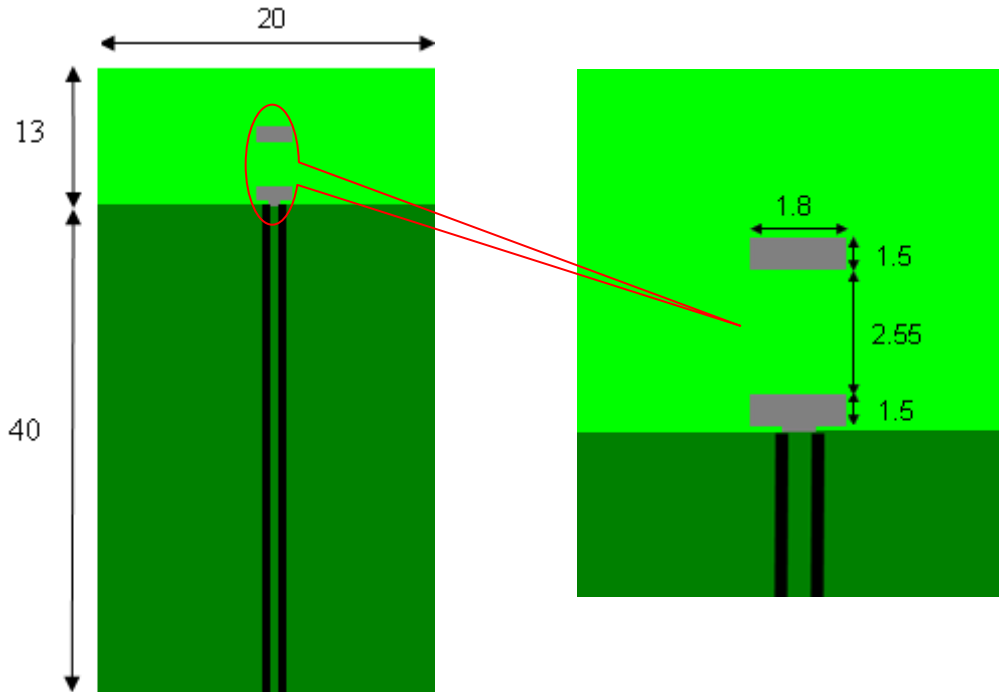

5. TERMINAL CONFIGURATION :

Top Layer :



Bottom Layer :



UNLESS OTHER SPECIFIED TOLERANCES ON :

X=± X.X=± X.XX=

ANGLES=± HOLEDIA=±

SCALE : xxxxx UNIT : mm

DRAWN BY:彭少君 CHECKED BY:謝立庭

DESIGNED BY:彭少君 APPROVED BY:謝立庭

TITLE : ACA-3216-A2-MC-S SPECIFICATION



INPAQ TECHNOLOGY CO., LTD.

THIS DRAWINGS AND SPECIFICATIONS ARE THE PROPERTY OF INPAQ TECHNOLOGY CO.,LTD.AND SHALL NOT BE REPRODUCED OR USED AS THE BASIS FOR THE MANUFACTURE OR SALE OF APPARATUS OR DEVICES WITHOUT PERMISSION

DOCUMENT NO.	ENS000015380	SPEC REV.
		A1

6. ELECTRICAL CHARACTERISTICS :

Return Loss

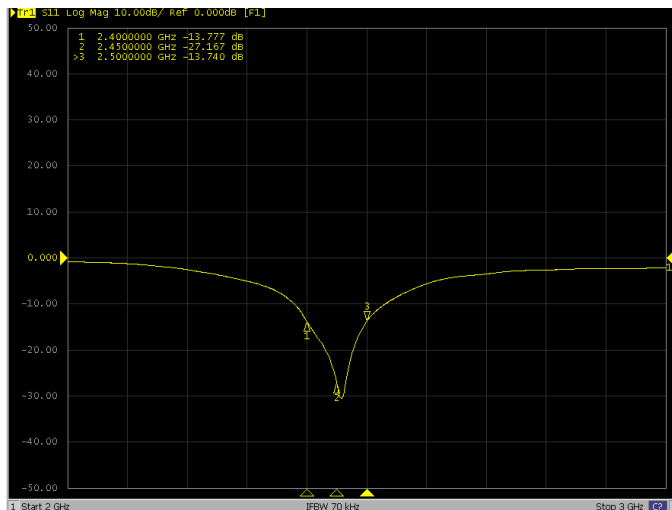

Freq.	Return Loss
2400 MHz	-13.78 dB
2450 MHz	-27.17 dB
2500 MHz	-13.74 dB

7. RADIATION PATTERN :

The gain pattern is measured in INPAQ's far-field chamber. AUT is placed on the table of rotator, a standard horn antenna and vector network analyzer is used to collect data. (Please contact with INPAQ for more detail)

● Measuring factors definition

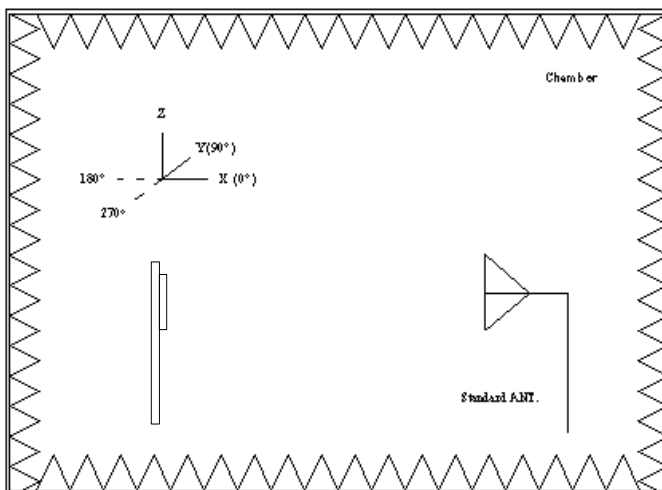
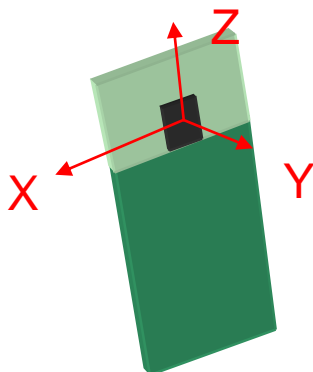

2400MHz

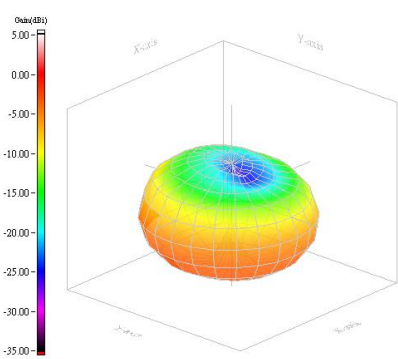

2450MHz

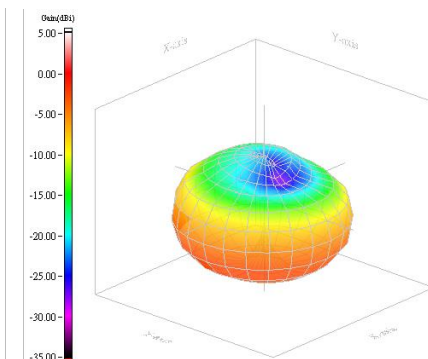

2500MHz

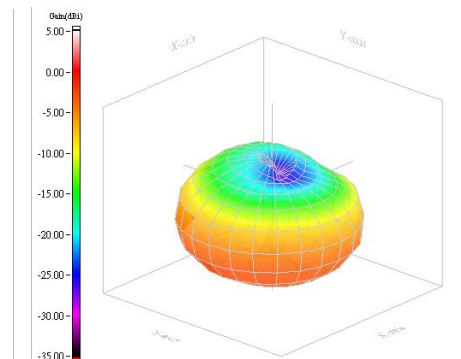

UNLESS OTHER SPECIFIED TOLERANCES ON :

X=± X.X=± X.XX=

ANGLES=± HOLEDIA=±

SCALE : xxxx UNIT : mm

DRAWN BY:彭少君 CHECKED BY:謝立庭

DESIGNED BY:彭少君 APPROVED BY:謝立庭

TITLE : ACA-3216-A2-MC-S SPECIFICATION



INPAQ TECHNOLOGY CO., LTD.

THIS DRAWINGS AND SPECIFICATIONS ARE THE PROPERTY OF INPAQ TECHNOLOGY CO.,LTD.AND SHALL NOT BE REPRODUCED OR USED AS THE BASIS FOR THE MANUFACTURE OR SALE OF APPARATUS OR DEVICES WITHOUT PERMISSION

DOCUMENT NO.

ENS000015380

SPEC REV.
A1

8. PACKAGING :

(1) Quantity : 4000pcs/Reel

(2) Carrier Tape Dimensions : (unit : mm)

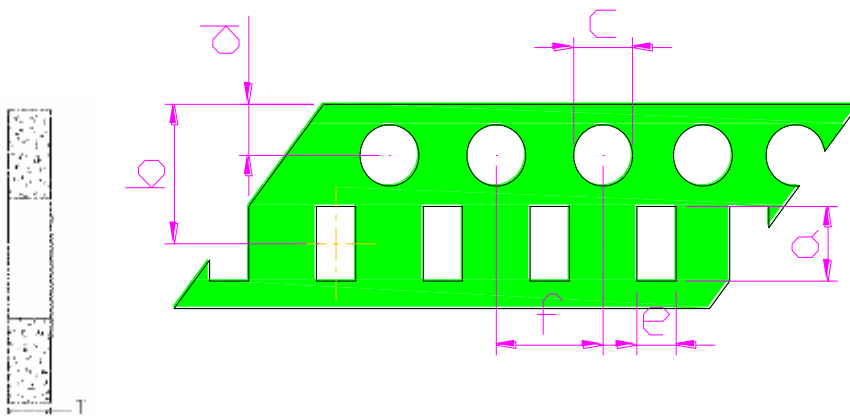

A	3.55±0.5
B	5.25±0.15
C	1.50±0.10
D	1.75±0.10
E	1.98±0.05
F	4.0±0.10
T	0.75±0.05

(3) Tape Packing

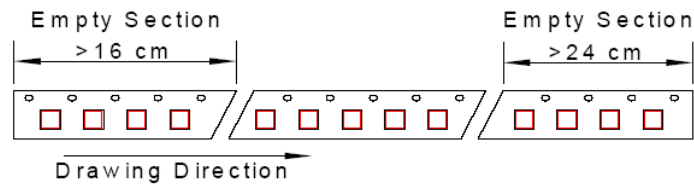

(4) Cover Tape Reel Off Force

$$5g \cdot f \leq \text{Peel-Off Force} \leq 70g \cdot f$$

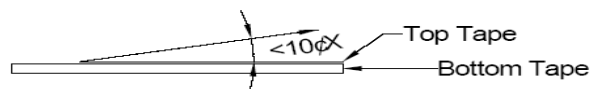

(5) Reel Dimensions: (unit: mm)

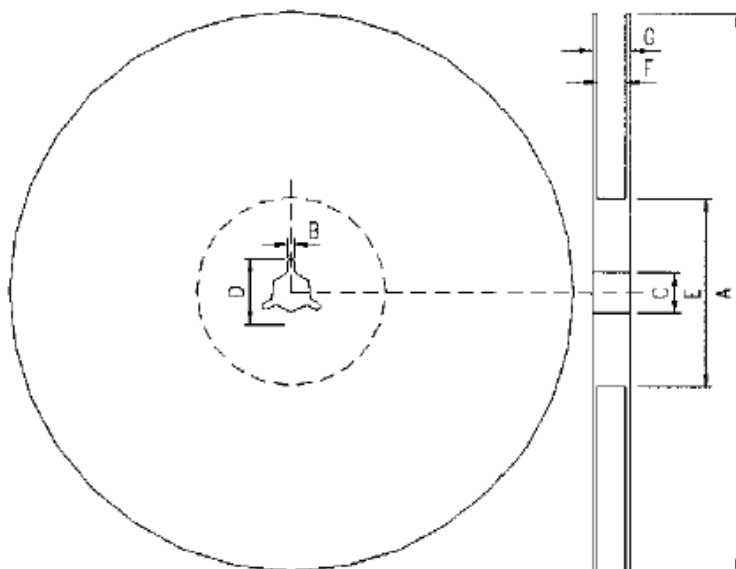

A	178.0±2.0
B	2.0±0.5
C	13.0±0.5
D	21.0±0.8
E	60.0±1.0
F	9.0±0.5
G	12.0±0.2

UNLESS OTHER SPECIFIED TOLERANCES ON :

X=± X.X=± X.XX=

ANGLES=± HOLEDIA=±

SCALE : xxx UNIT : mm

DRAWN BY: 彭少君 CHECKED BY: 謝立庭

DESIGNED BY: 彭少君 APPROVED BY: 謝立庭

TITLE : ACA-3216-A2-MC-S SPECIFICATION



INPAQ TECHNOLOGY CO., LTD.

THIS DRAWINGS AND SPECIFICATIONS ARE THE PROPERTY OF INPAQ TECHNOLOGY CO.,LTD.AND SHALL NOT BE REPRODUCED OR USED AS THE BASIS FOR THE MANUFACTURE OR SALE OF APPARATUS OR DEVICES WITHOUT PERMISSION

DOCUMENT NO.

ENS000015380

SPEC REV.

A1

9. Environmental Specifications :

(1) Reliability Test

Item	Condition	Specification
Thermal shock	1. 30±3 minutes at -40°C±5°C, 2. Convert to +105°C (5 minutes) 3. 30±3 minutes at +105°C±5°C, 4. Convert to -40°C (5 minutes) 5. Total 24 continuous cycles	No apparent damage Fulfill the electrical spec. after test.
Humidity resistance	1. Humidity: 85% R.H. 2. Temperature: 85±5°C 3. Time: 500 hours.	No apparent damage Fulfill the electrical spec. after test.
High temperature resistance	1. Temperature: 150°C±5°C 2. Time: 1000 hours.	No apparent damage Fulfill the electrical spec. after test.
Low temperature resistance	1. Temperature: -40°C±5°C 2. Time: 1000 hours.	No apparent damage Fulfill the electrical spec. after test.
Soldering heat resistance	1. Solder bath temperature : 260±5°C 2. Bathing time: 10±1 seconds	No apparent damage
Solderability	The dipped surface of the terminal shall be at least 95% covered with solder after dipped in solder bath of 245±5°C for 3±1 seconds.	No apparent damage

(2) Storage condition

(a) At warehouse :

The temperature should be within 0 ~ 30°C and humidity should be less than 75% RH.

The product should be used within 1 year from the time of delivery.

(b) On board :

The temperature should be within -40~85°C and humidity should be less than 85% RH.

(3) Operating temperature range

Operating temperature range : -40°C to +105°C.

UNLESS OTHER SPECIFIED TOLERANCES ON :			INPAQ TECHNOLOGY CO., LTD.	
X=±	X.X=±			X.XX=
ANGLES=±				HOLEDIA=±
SCALE : xxxx	UNIT : mm	THIS DRAWINGS AND SPECIFICATIONS ARE THE PROPERTY OF INPAQ TECHNOLOGY CO.,LTD.AND SHALL NOT BE REPRODUCED OR USED AS THE BASIS FOR THE MANUFACTURE OR SALE OF APPARATUS OR DEVICES WITHOUT PERMISSION		
DRAWN BY:彭少君	CHECKED BY:謝立庭			
DESIGNED BY:彭少君	APPROVED BY:謝立庭			
TITLE : ACA-3216-A2-MC-S SPECIFICATION		DOCUMENT NO.	ENS000015380	SPEC REV. A1

10. Recommendable reflow soldering :

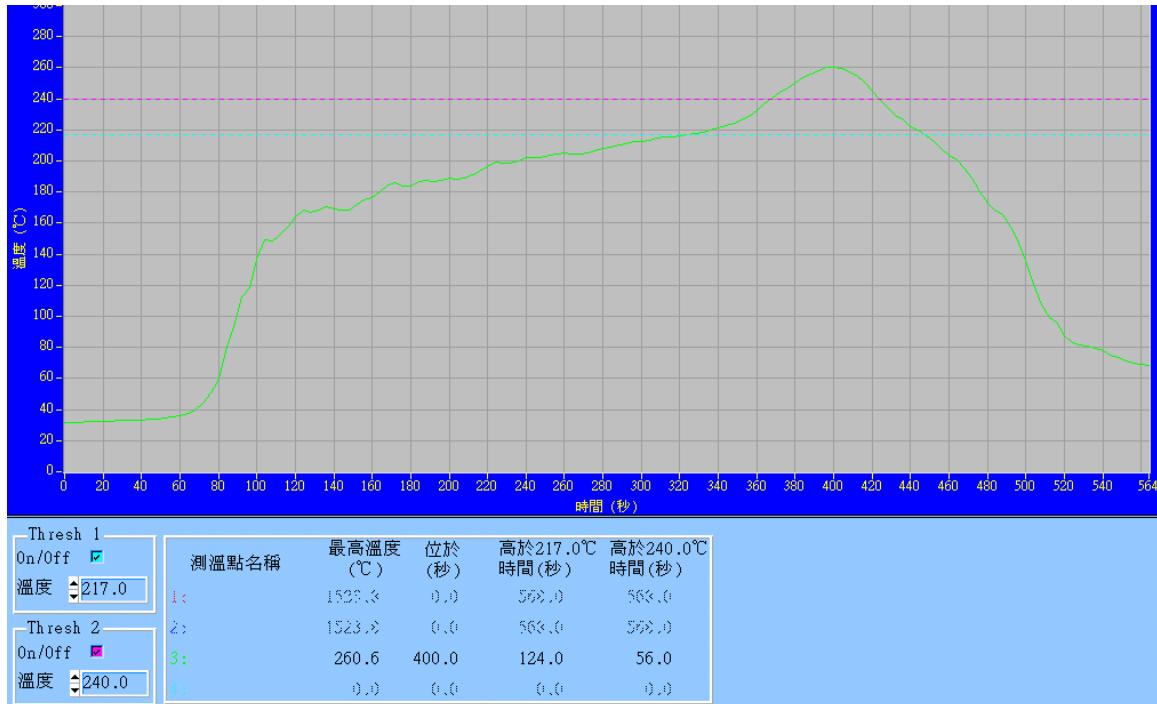

(1) Soldering gun procedure

Note the follows, in case of using solder gun for replacement.

- (a) The tip temperature must be less than 350°C for the period within 3 seconds by using soldering gun under 30 W.
- (b) The soldering gun tip shall not touch this product directly.

(2) Soldering volume

Note that excess of soldering volume will easily get crack the body of this Product.

UNLESS OTHER SPECIFIED TOLERANCES ON :			INPAQ TECHNOLOGY CO., LTD.
X=±	X.X=±		
ANGLES=±		HOLEDIA=±	
SCALE : xxxx	UNIT : mm		
DRAWN BY:彭少君	CHECKED BY:謝立庭		
DESIGNED BY:彭少君	APPROVED BY:謝立庭		
TITLE : ACA-3216-A2-MC-S SPECIFICATION		DOCUMENT NO.	ENS000015380
		SPEC REV. A1	