

REV.	ECN NO./DESCRIPTION	DATE
17	N180324	07/17'18
18	N190150	05/29'19
19	NZ20030	08/08'20

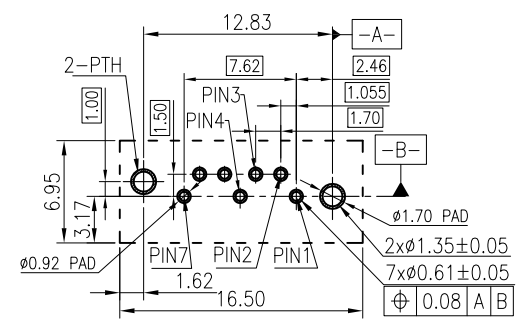
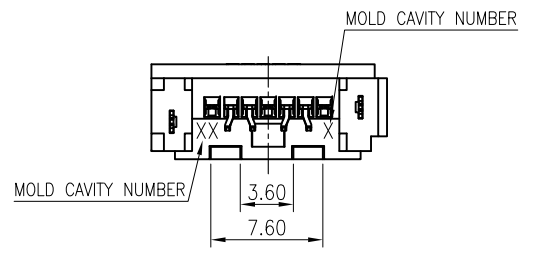
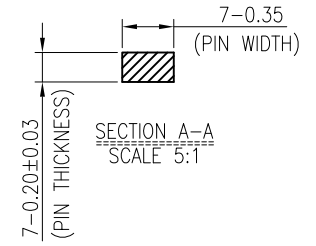
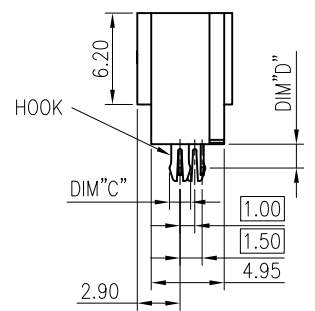
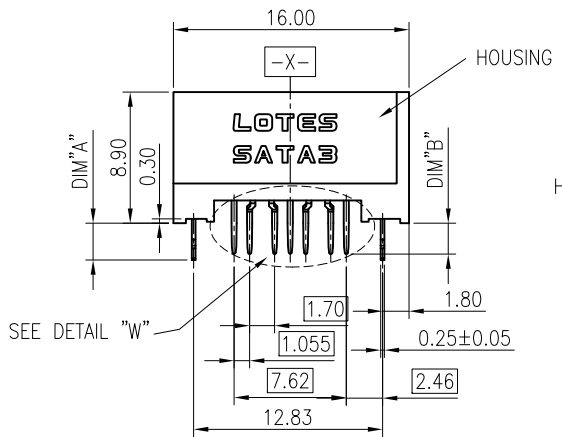
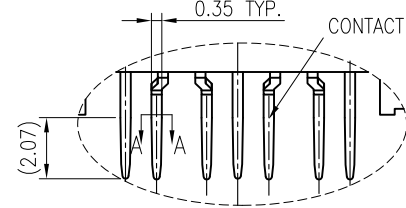
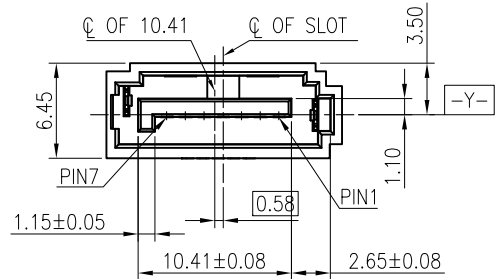
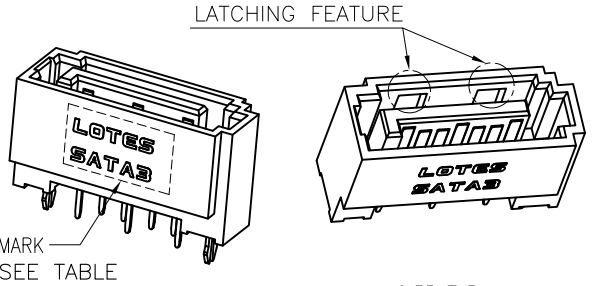

RECOMMENDED PC BOARD LAYOUT(TOP VIEW)
(THICKNESS:1.60mm;DEFAULT TOLERANCE ±0.05)

- MATERIAL SPECIFICATION,
 - HOUSING:SEE TABLE;
 - CONTACT:BRASS(C2680);
 - HOOK:BRASS(C2680);
 - CAP:SEE TABLE;
- PLATING SPECIFICATION,
 - CONTACT:
UNDER PLATING: Ni 50u" Min PLATED OVER ALL;
CONTACT AREA: SEE TABLE;
SOLDER TAIL: MATTE TIN 100u" Min PLATED;
 - HOOK: MATTE TIN 100u" Min PLATED OVER Ni 50u" Min.
- MECHANICAL PERFORMANCE,
 - INSERTION FORCE:45N Max
 - REMOVAL FORCE:10N Min
 - DURABILITY:50 CYCLES
- ELECTRICAL PERFORMANCE,
 - CURRENT RATING:1.5A Max
 - LLCR:25 MILLIOHMS Max.
 - INSULATION RESISTANCE:1000 MEGAOHMS Min.
 - DIELECTRIC WITHSTAND VOLTAGE:500VRMS AT SEA LEVEL
- RoHS OR HF COMPLIANT
- PCB HOLE PARAMETERS:
 - FINISHED HOLE: 24 MILS
 - DRILL HOLE SIZE: 27 MILS
 - PAD SIZE: 39 MILS
 - ANTI-PAD: 60 MILS
- WAVE SOLDER:
THE CONNECTOR SHALL BE MOUNTED ON THE PCB;THE TEMPERATURE OF THE SOLDER SHALL BE 260±5°C, AND IMMERTION DURATION:3~5SECONDS.
- MARK "LOTES SATA3" or "LOTES" SEE TABLE;

GENERAL TOLERANCES UNLESS SPECIFIED		PART NO.	LOTES		
X± 0.35	X°± 3°	SEE TABLE	TITLE SATA3.0 7PIN CONN. WITH SHROUD,T/H,VERTICAL		
.XX± 0.25	.X°± 2°	APPROVED BY Jie_Liao	DWG NO. GAP-ABA-SAT-054		
.XXX± 0.15	.XX°± 1°	CHECKED BY Yong_Liu	SHEET 1 / 3		
CUSTOMER DRAWING		DRAWN BY Wei_He	SCALE 2:1	REV 19	

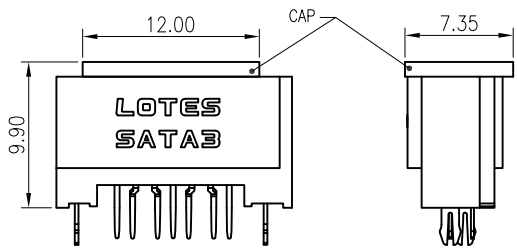

WITH CAP

REV.	ECN NO./DESCRIPTION	DATE
17	N180324	07/17'18
18	N190150	05/29'19
19	NZ20030	08/08'20

PRODUCT NUMBER NOTE:

A B A - S A T - 0 5 4 - X X X

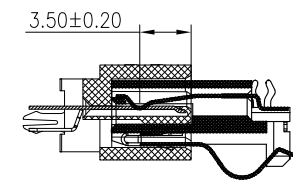
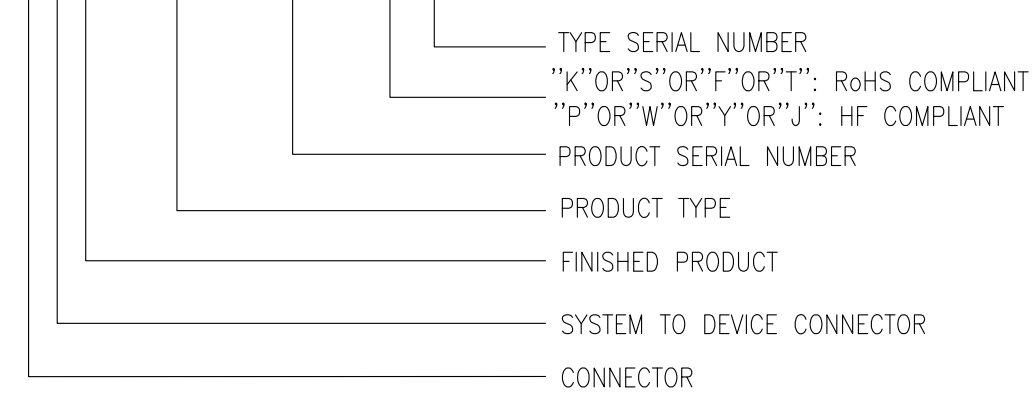

Matting. Dimension

GENERAL TOLERANCES UNLESS SPECIFIED		PART NO.	LOTES		
.X± 0.35	X°± 3°	SEE TABLE			
.XX± 0.25	X°± 2°	APPROVED BY	TITLE SATA3.0 7PIN CONN. WITH SHROUD,T/H,VERTICAL		
.XXX± 0.15	.XX°± 1°	Jie_liao			
CUSTOMER DRAWING		CHECKED BY	DWG NO. GAP-ABA-SAT-054		
		Yong_liu			
SIZE	UNITS	DRAWN BY	SHEET SCALE REV		
A4	mm[inch]	Wei_He			

REV.	ECN NO./DESCRIPTION	DATE
17	N180324	07/17'18
18	N190150	05/29'19
19	NZ20030	08/08'20

3. Put the 30 trays of products into a water-repellent film, then put all of them into a carton.

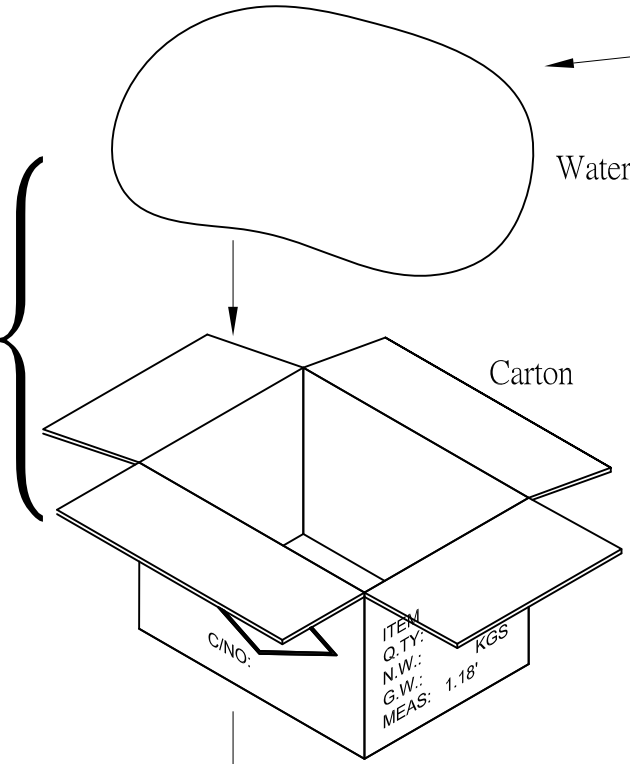

4. Packed the carton, and the seal looks like "工" shape.

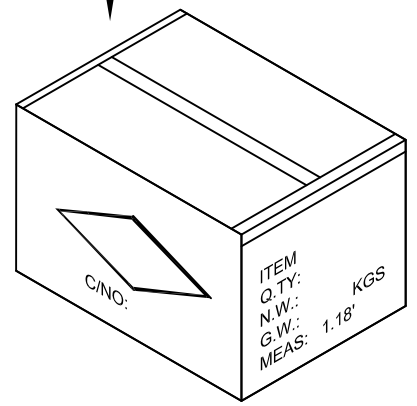

Water-repellent film

Carton

An empty tray on the top

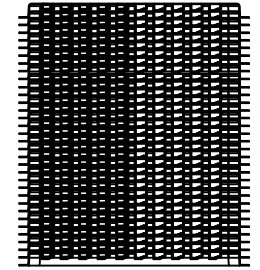

2. Each 30 trays of products puts together, one tray over another one, like the picture shows, 6300pcs products in all.

Product

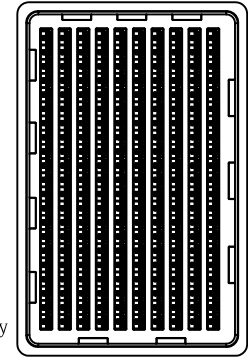

1. Put the good products which had inspected into the tray, 210 pcs per tray.

GENERAL TOLERANCES UNLESS SPECIFIED		PART NO.	LOTES		
.X ± 0.35	X° ± 3°	SEE TABLE			
.XX ± 0.25	X° ± 2°	APPROVED BY	TITLE SATA3.0 7PIN CONN. WITH SHROUD,T/H,VERTICAL		
.XXX ± 0.15	.XX° ± 1°	Jie_liao			
CUSTOMER DRAWING		CHECKED BY	DWG NO. GAP-ABA-SAT-054		
		Yong_liu			
SIZE	UNITS	DRAWN BY	SHEET SCALE REV		
A4	mm[inch]	Wei_He			

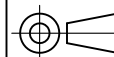



PRODUCT P/N	DESCRIPTION	DIM"A"	DIM"B"	DIM"C"	DIM"D"	MARK	PACKING/CAP
ABA-SAT-054-K32	PA66+30%GF; UL94V-0_BLACK; Au1u"	2.50	2.30	1.43	1.62	LOTES	TRAY/WITHOUT