

13 12 11 10 9 8 7 6 5 4 3 2 1

MATERIALS AND FINISHS

SMA JACK STRIGHT CONNECTOR

BODY, CRIMP TUBE BRASS  
PLATED GOLD

CENTER CONTACT BERYLLIUM COPPER  
PLATED GOLD

INSULATOR TEFLON

GASKET SILICONE RUBBER

JAM NUT BRASS  
PLATED GOLD

LOCK WASHER PHOSPHOR BRONZE  
PLATED GOLD

SMA PLUG STRIGHT CONNECTOR

BODY, CENTER CONTACT, CRIMP TUBE, COUPLING NUT BRASS  
PLATED GOLD

INSULATOR TEFLON

C RING BERYLLIUM COPPER

GASKET SILICONE RUBBER

HEAT SHRINK TUBE  
VERSAFIT V2

CABLE 1.37

PART # 89761-4820

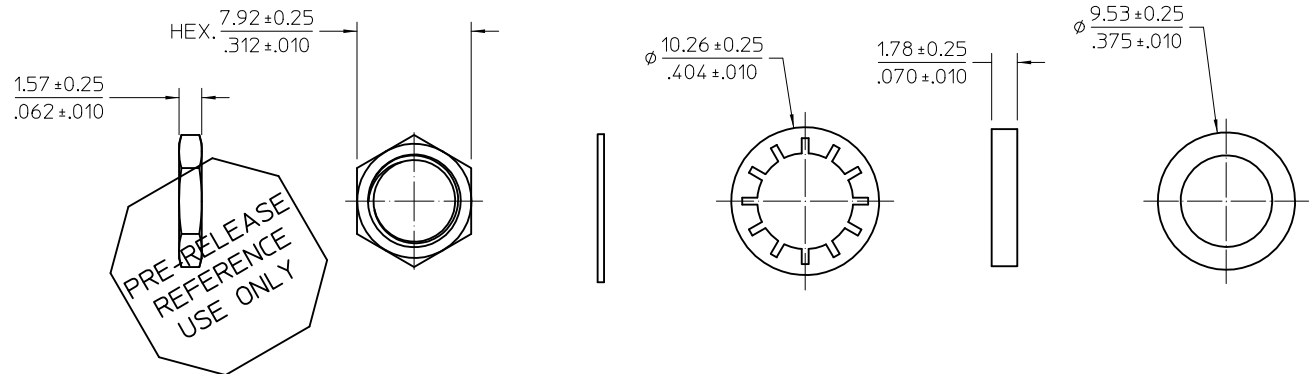
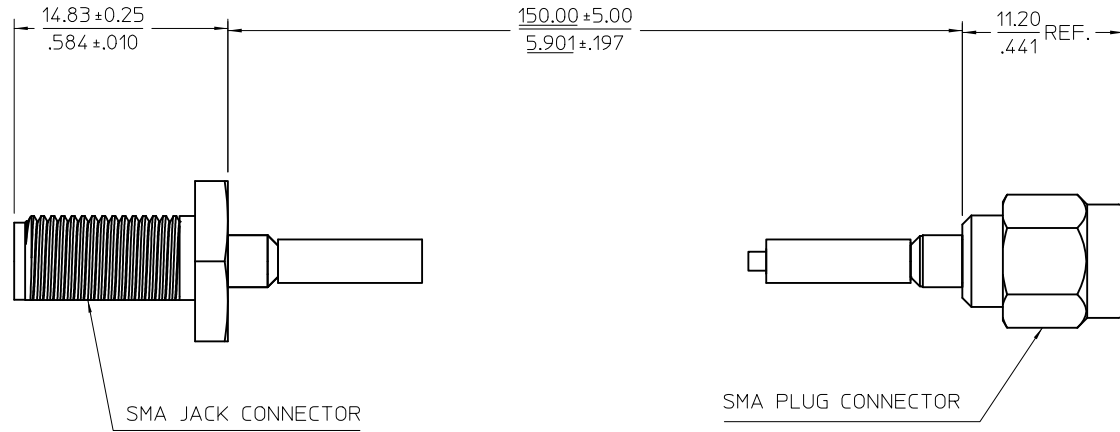

PRE-RELEASE  
REFERENCE  
USE ONLY

B	A	REV	DESCRIPTION	QUALITY SYMBOLS	GENERAL TOLERANCES (UNLESS SPECIFIED)		DIMENSION STYLE		SCALE	DESIGN UNITS	THIRD ANGLE PROJECTION		
					mm	INCH	MM/IN		METRIC	M			
		EC NO:	2010/04/19	▽=0	4 PLACES	±	---	---	DRAWN BY	DATE	TITLE		
		DRWNLN		▽=0	3 PLACES	±	---	---	ELIN	2010/04/19	CABLE ASSY SMA JACK STR. TO SMA PLUG STR. 1.37		
		CHKD:			2 PLACES	±	---	---	CHECKED BY	DATE	CABLE CA-SMA-J/SMA-P		
		APPR:			1 PLACE	±	---	---	KERR IE	2010/04/19	MOLEX INCORPORATED		
		1			ANGULAR ± 2 °			APPROVED BY		DATE	MATERIAL NO.		
					DRAFT WHERE APPLICABLE MUST REMAIN WITHIN DIMENSIONS			897614820			DOCUMENT NO.		
								SD-89761-482			SHEET NO.		
								C		THIS DRAWING CONTAINS INFORMATION THAT IS PROPRIETARY TO MOLEX INCORPORATED AND SHOULD NOT BE USED WITHOUT WRITTEN PERMISSION		1 OF 1	

12 11 10 9 8 7 6 5 4 3 2 1