

TABELA 1
CHART 1

MOLEX PN	WOODHEAD PN	L(mm)	TYP KONEKTORA
1200110013	8R4E30E03C3003	300	4 POL. FE
1200110033	8R5E30E03C3003	300	5 POL. FE
1200110216	8R4E30E03C5003	500	4 POL. FE
1200110330	8R8E30E03C3003	300	8 POL. FE
1200110474	8R4E30E03C6003	600	4 POL. FE
1200110670	8R8E30E03C6003	600	8 POL. FE
1200708008	8R4E30E04C3003	300	4 POL. FE
1200708021	8R5E30E03C5003	500	5 POL. FE
1200708022	8R5E30E03C8003	800	5 POL. FE
1200708036	8R8E30E03C5003	500	8 POL. FE
1200708079	8R8E30E03C3001	300	8 POL. FE
1200708093	8R4E30E03C7003	700	4 POL. FE

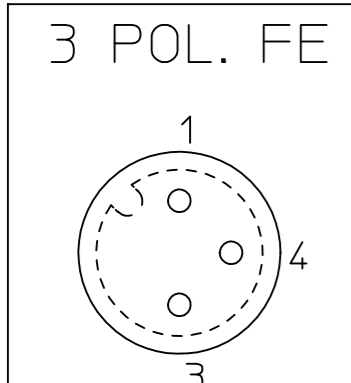

OBUDOWA ZENSKA 3 POLOWA
WIDOK OD STRONY DRUTOW
FEMALE INSERT 3P
VIEW FROM WIRES SIDE

Pin	Kolor przew.	Wire color
1	Brazowy	BN
2	-	-
3	Niebieski	BU
4	Czarny	BK

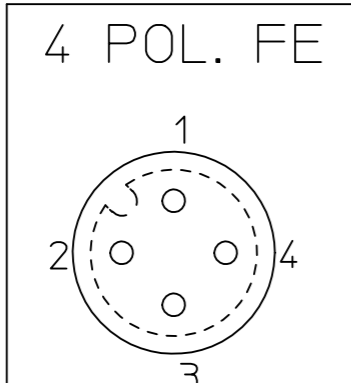

OBUDOWA ZENSKA 4 POLOWA
WIDOK OD STRONY DRUTOW
FEMALE INSERT 4P
VIEW FROM WIRES SIDE

Pin	Kolor przew.	Wire color
1	Brazowy	BN
2	Bialy	WH
3	Niebieski	BU
4	Czarny	BK

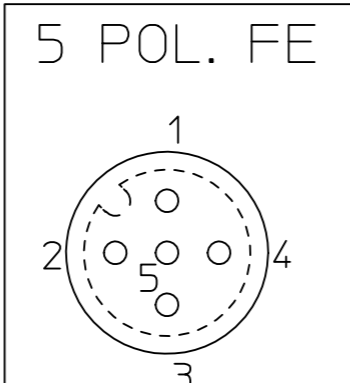

OBUDOWA ZENSKA 5 POLOWA
WIDOK OD STRONY DRUTOW
FEMALE INSERT 5P
VIEW FROM WIRES SIDE

Pin	Kolor przew.	Wire color
1	Brazowy	BN
2	Bialy	WH
3	Niebieski	BU
4	Czarny	BK
5	Szary	GY

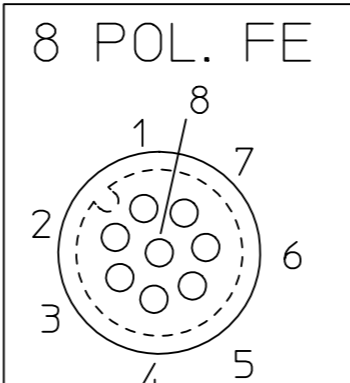

OBUDOWA ZENSKA 8 POLOWA
WIDOK OD STRONY DRUTOW
FEMALE INSERT 8P
VIEW FROM WIRES SIDE

Pin	Kolor przew.	Wire color
1	Bialy	WH
2	Brazowy	BN
3	Zielony	GN
4	Zolty	YE
5	Szary	GY
6	Rozowy	PK
7	Niebieski	BU
8	Czerwony	RD

PART No MATRIX

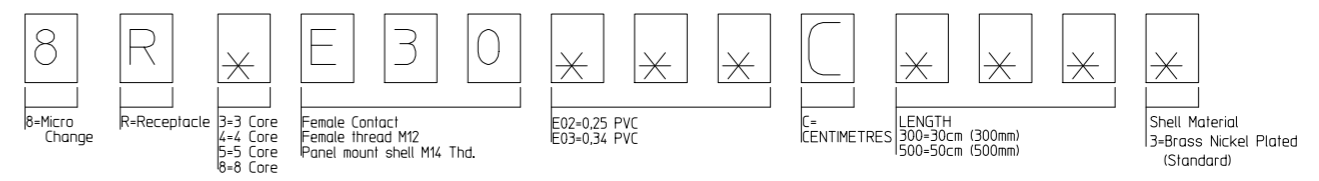

Tablica tolerancji dlugosci
Table of length tolerances

Powyzej Over	Do-wlacznie Up to and including	Tolerancja (+) Tolerance
0	305	+19
305	915	+45
915	1830	+56
1830	3660	+89
3660	7320	+165
7320	14640	+317
14640	30500	+622
30500	>	+2% dlugosci of length

NAKRETKA
LOCKNUT

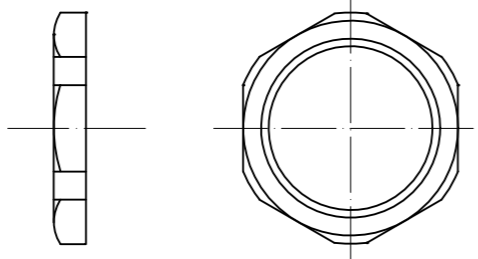

KOLNIERZ
FLANGE

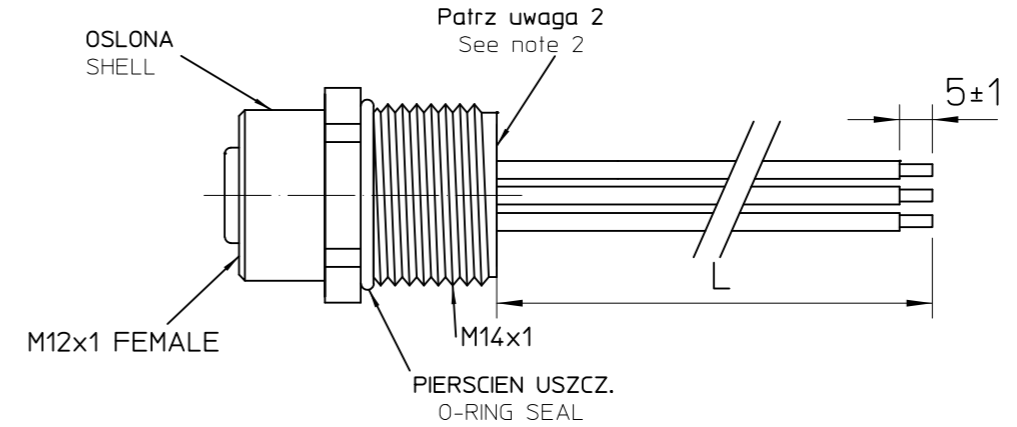
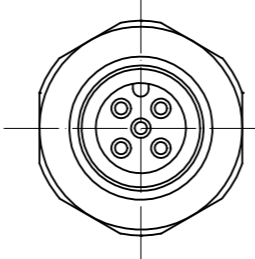

- UWAGI:
- DLUGOSCI CIECIA PRZEWODOW I SPECYFIKACJE NABIJANIA W LISCIE CIECIA.
 - PO OSADZENIU TERMINALI ZALAC KLEJEM.

- NOTES:
- FOR WIRES CUTTING LENGTHS AND CRIMPING SPECIFICATIONS SEE THE CUTTING LIST.
 - AFTER ASSEMBLED TERMINALS THE CONNECTOR MUST BE FLOOD BY GLUE.

ORIGINAL RELEASE EC NO: DRWN:DWARWAS 2008/05/13 CHKD: APPR:	DESCRIPTION REV	QUALITY SYMBOLS ▽=0 ▽=0	GENERAL TOLERANCES (UNLESS SPECIFIED)	DIMENSION STYLE	SCALE 1	DESIGN UNITS	FIRST ANGLE PROJECTION	
			mm INCH	DRAWN BY DWARWAS	DATE 2008/05/13	TITLE MMC-xP-FE-REC-M14-xxM-PVC		
			4 PLACES ± ± 3 PLACES ± ± 2 PLACES ± ± 1 PLACE ± ±	APPROVED BY MWOLSZCZAK	DATE 2008/06/06	MATERIAL NO. See Chart 1	DOCUMENT NO. 8RxE30xxxCxxxx	SHEET NO. 1 OF 1
			ANGULAR ± °	THIS DRAWING CONTAINS INFORMATION THAT IS PROPRIETARY TO MOLEX INCORPORATED AND SHOULD NOT BE USED WITHOUT WRITTEN PERMISSION				