

品名 : ACA-2012-P1-CC-S

1.Explanation of part number :

AC	A	2012	P1	CC	S
Product Type	Center Frequency/Band Code	Product Code (Unit: mm)	Design Revision Code	Antenna Type	Special Code
Chip Antenna	A: 2.4GHz E: Cellular G:868MHz H:915MHz L:5GHz M3:2G+5GHz N:NFC	Per 2 digits of length, width e.g.: 2012 2.0*1.2(Length * Width)	P1:Rev.1	CC: Coupling Ceramic GF: On Ground, FR4 LC: Loop ceramic MC: Monopole Ceramic MF: Monopole FR4 PF: PIFA FR4	S: RoHS Compliant

2.Electrical Specification :

	Specification
Working Frequency Range	2.4GHz ~ 2.5GHz (Note-1)
Gain	0.29 dBi (Typical)
VSWR	≤ 2.6
Polarization	Linear
Azimuth Bandwidth	Omni-directional
Impedance	50Ω

UNLESS OTHER SPECIFIED TOLERANCES ON : X=N/A X.X=N/A X.XX=N/A ANGLES=N/A HOLEDIA=N/A			INPAQ TECHNOLOGY CO., LTD.	
SCALE : N/A	UNIT : mm			THIS DRAWINGS AND SPECIFICATIONS ARE THE PROPERTY OF INPAQ TECHNOLOGY CO.,LTD.AND SHALL NOT BE REPRODUCED OR USED AS THE BASIS FOR THE MANUFACTURE OR SALE OF APPARATUS OR DEVICES WITHOUT PERMISSION
DRAWN BY : 詹惠雯	CHECKED BY : 詹惠雯			
DESIGNED BY : 黃瑞郎	APPROVED BY : 陳振榮			
TITLE : ACA-2012-P1-CC-S		DOCUMENT NO.	ENS070001760-000824000157	SPEC REV. A0

3. Antenna Drawing :

CONSTRUCTION

Top view

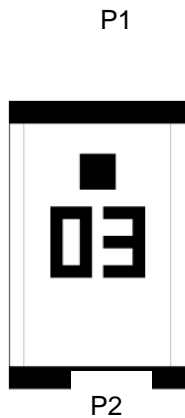

PIN	Connection
1	Feeding
2	Soldering terminal

DIMENSIONS

Figure	Symbol	Dimension (mm)
	L	2.0 ± 0.20
	W	1.20 ± 0.20
	T	0.50 ± 0.10
	A	0.15 ± 0.10

UNLESS OTHER SPECIFIED TOLERANCES ON :
 X=N/A X.X=N/A X.XX=N/A
 ANGLES=N/A HOLEDIA=N/A



INPAQ TECHNOLOGY CO., LTD.

SCALE : N/A

UNIT : mm

DRAWN BY : 詹惠雯

CHECKED BY : 詹惠雯

DESIGNED BY : 黃瑞郎

APPROVED BY : 陳振榮

THIS DRAWINGS AND SPECIFICATIONS ARE THE PROPERTY OF INPAQ TECHNOLOGY CO.,LTD.AND SHALL NOT BE REPRODUCED OR USED AS THE BASIS FOR THE MANUFACTURE OR SALE OF APPARATUS OR DEVICES WITHOUT PERMISSION

TITLE : ACA-2012-P1-CC-S

DOCUMENT NO.

ENS070001760-000824000157

SPEC REV.
A0

4. Performance Report :

SOLDER LAND PATTERN DESIGN

Figure (Empty Space 5.0 mm x 3.0 mm)

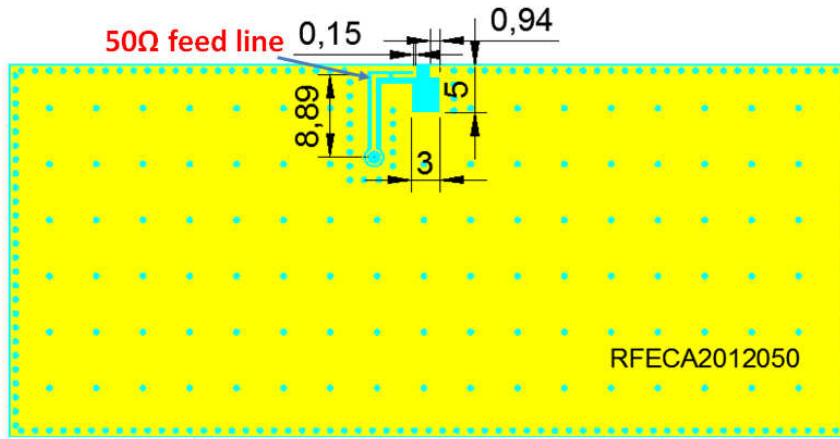

The limited size for ECA2012 is L > 30 mm and D > 6mm

Unit : mm

Land pattern

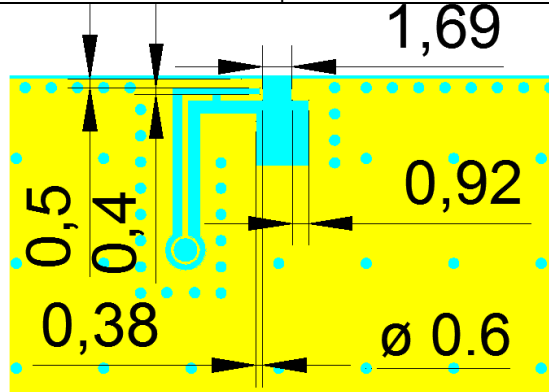

UNLESS OTHER SPECIFIED TOLERANCES ON :
 X=N/A X.X=N/A X.XX=N/A
 ANGLES=N/A HOLEDIA=N/A



INPAQ TECHNOLOGY CO., LTD.

SCALE : N/A

UNIT : mm

DRAWN BY : 詹惠雯

CHECKED BY : 詹惠雯

DESIGNED BY : 黃瑞郎

APPROVED BY : 陳振榮

THIS DRAWINGS AND SPECIFICATIONS ARE THE PROPERTY OF INPAQ TECHNOLOGY CO.,LTD.AND SHALL NOT BE REPRODUCED OR USED AS THE BASIS FOR THE MANUFACTURE OR SALE OF APPARATUS OR DEVICES WITHOUT PERMISSION

TITLE : ACA-2012-P1-CC-S

DOCUMENT NO.

ENS070001760-000824000157

SPEC REV.
A0

Antenna on Test Board (Thickness 0.8mm)

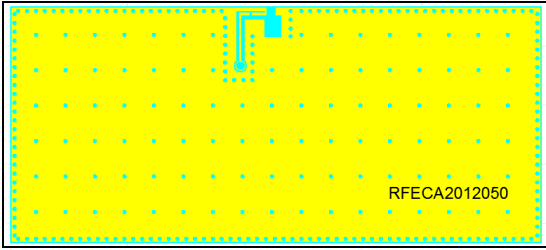

Antenna S11 on Test Board

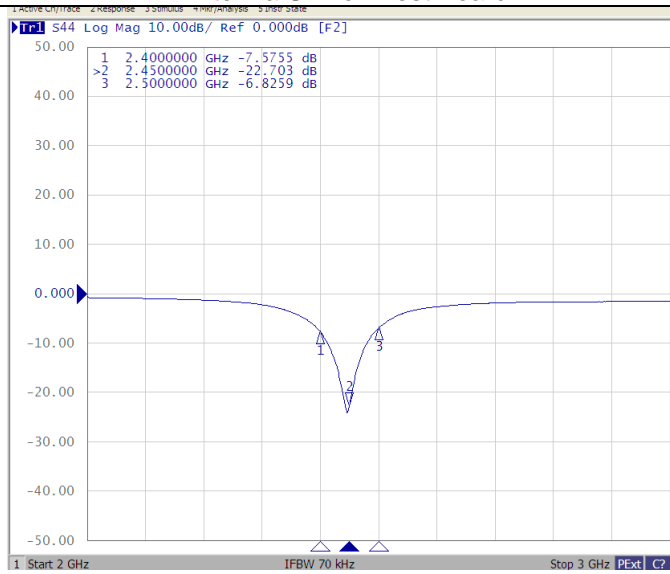

Antenna VSWR on Test Board

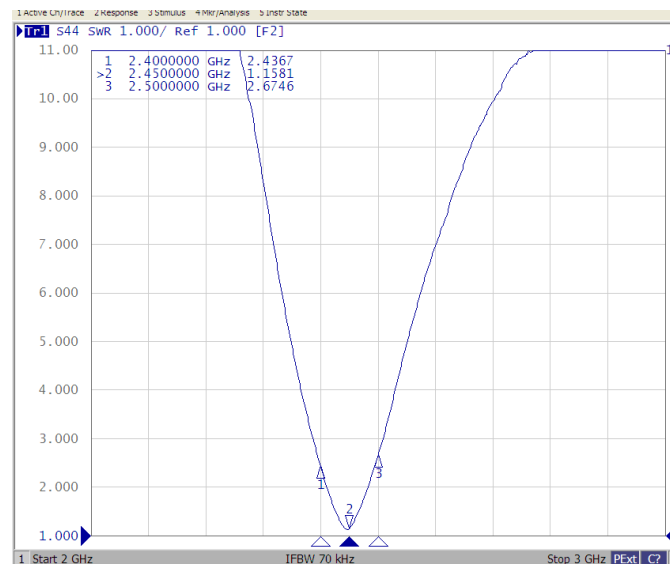

UNLESS OTHER SPECIFIED TOLERANCES ON : X=N/A X.X=N/A X.XX=N/A ANGLES=N/A HOLEDIA=N/A		 INPAQ TECHNOLOGY CO., LTD.
SCALE : N/A	UNIT : mm	
DRAWN BY : 詹惠雯	CHECKED BY : 詹惠雯	THIS DRAWINGS AND SPECIFICATIONS ARE THE PROPERTY OF INPAQ TECHNOLOGY CO.,LTD.AND SHALL NOT BE REPRODUCED OR USED AS THE BASIS FOR THE MANUFACTURE OR SALE OF APPARATUS OR DEVICES WITHOUT PERMISSION
DESIGNED BY : 黃瑞郎	APPROVED BY : 陳振榮	
TITLE : ACA-2012-P1-CC-S		DOCUMENT NO. ENS070001760-000824000157
		SPEC REV. A0

RADIATION PATTERN

Radiation Pattern and Gain were dependent on measurement board design. The specification of ACA-2012-P1-CC-S antenna was measured based on the PCB size and installation position as shown in the below figure Test Board.

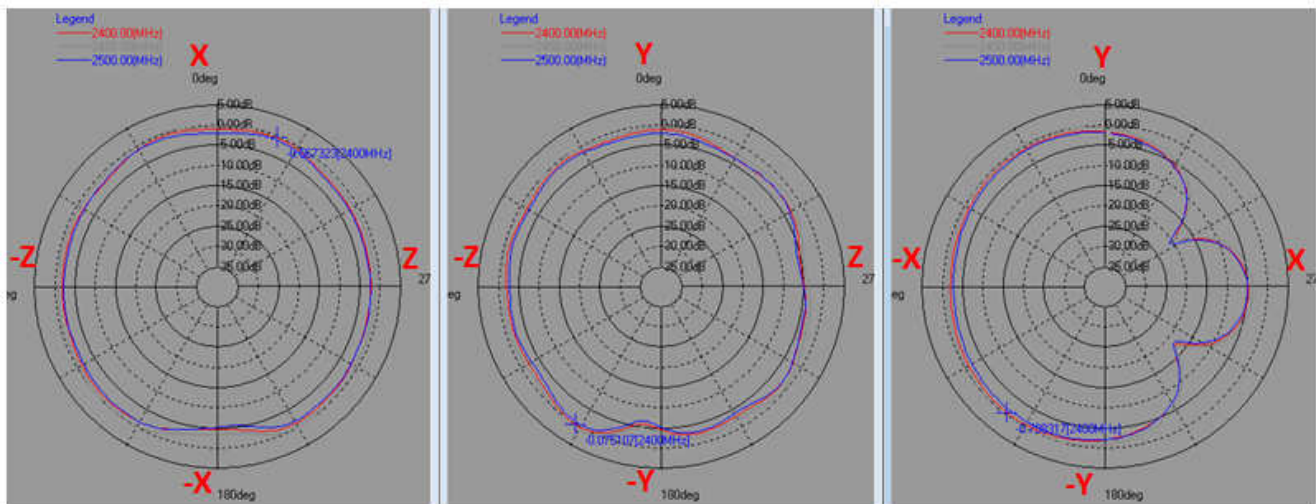
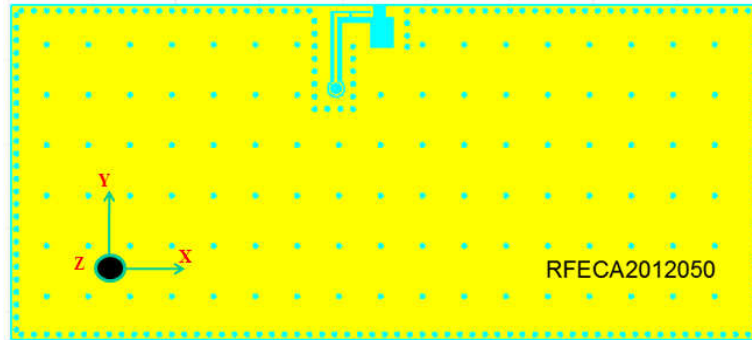

	ZX plane		ZY plane		XY plane	
Frequency [MHz]	Max Value [dB]	Average [dB]	Max Value [dB]	Average [dB]	Max Value [dB]	Average [dB]
2400	-0.57	-1.91	-0.02	-4.53	-1.07	-3.81
2450	0.29	-0.89	0.03	-4.36	-1.21	-4.09
2500	-1.13	-2.27	-0.67	-4.63	-1.89	-4.79

UNLESS OTHER SPECIFIED TOLERANCES ON :
 X=N/A X.X=N/A X.XX=N/A
 ANGLES=N/A HOLEDIA=N/A



INPAQ TECHNOLOGY CO., LTD.

SCALE : N/A UNIT : mm
 DRAWN BY : 詹惠雯 CHECKED BY : 詹惠雯
 DESIGNED BY : 黃瑞郎 APPROVED BY : 陳振榮

THIS DRAWINGS AND SPECIFICATIONS ARE THE PROPERTY OF INPAQ TECHNOLOGY CO.,LTD.AND SHALL NOT BE REPRODUCED OR USED AS THE BASIS FOR THE MANUFACTURE OR SALE OF APPARATUS OR DEVICES WITHOUT PERMISSION

TITLE : ACA-2012-P1-CC-S

DOCUMENT NO. ENS070001760-000824000157 SPEC REV. A0

5. RELIABILITY TEST

Test item	Test condition / Test method	Specification
Solderability JIS C 0050-4.6 JESD22-B102D	*Solder bath temperature : 235 ± 5°C *Immersion time : 2 ± 0.5 sec *Solder : Sn3Ag0.5Cu for lead-free	At least 95% of a surface of each terminal electrode must be covered by fresh solder.
Leaching (Resistance to dissolution of metallization) IEC 60068-2-58	*Solder bath temperature : 260 ± 5°C *Leaching immersion time : 30 ± 0.5 sec *Solder : SN63A	Loss of metallization on the edges of each electrode shall not exceed 25%.
Resistance to soldering heat JIS C 0050-5.4	*Preheating temperature : 120~150°C, 1 minute. *Solder temperature : 270±5°C *Immersion time : 10±1 sec *Solder : Sn3Ag0.5Cu for lead-free Measurement to be made after keeping at room temperature for 24±2 hrs	No mechanical damage. Samples shall satisfy electrical specification after test. Loss of metallization on the edges of each electrode shall not exceed 25%.
Drop Test JIS C 0044	*Height : 75 cm *Test Surface : Rigid surface of concrete or steel. *Times : 6 surfaces for each units ; 2 times for each side.	No mechanical damage. Samples shall satisfy electrical specification after test.
Adhesive Strength of Termination JIS C 0051- 7.4.3	*Pressurizing force : 5N(≤0603) ; 10N(>0603) *Test time : 10±1 sec	No remarkable damage or removal of the termination.
Bending test JIS C 0051- 7.4.1	The middle part of substrate shall be pressurized by means of the pressurizing rod at a rate of about 1 mm/s per second until the deflection becomes 1mm/s and then pressure shall be maintained for 5±1 sec. Measurement to be made after keeping at room temperature for 24±2 hours	No mechanical damage. Samples shall satisfy electrical specification after test.

UNLESS OTHER SPECIFIED TOLERANCES ON :
 X=N/A X.X=N/A X.XX=N/A
 ANGLES=N/A HOLEDIA=N/A



INPAQ TECHNOLOGY CO., LTD.

SCALE : N/A

UNIT : mm

DRAWN BY : 詹惠雯

CHECKED BY : 詹惠雯

DESIGNED BY : 黃瑞郎

APPROVED BY : 陳振榮

THIS DRAWINGS AND SPECIFICATIONS ARE THE PROPERTY OF INPAQ TECHNOLOGY CO.,LTD.AND SHALL NOT BE REPRODUCED OR USED AS THE BASIS FOR THE MANUFACTURE OR SALE OF APPARATUS OR DEVICES WITHOUT PERMISSION

TITLE : ACA-2012-P1-CC-S

DOCUMENT NO.

ENS070001760-000824000157

SPEC REV.
A0

Temperature cycle JIS C 0025	<ol style="list-style-type: none"> 30±3 minutes at -40°C±3°C, 10~15 minutes at room temperature, 30±3 minutes at +85°C±3°C, 10~15 minutes at room temperature, Total 100 continuous cycles Measurement to be made after keeping at room temperature for 24±2 hrs	No mechanical damage. Samples shall satisfy electrical specification after test.
Vibration JIS C 0040	*Frequency : 10Hz~55Hz~10Hz(1min) *Total amplitude : 1.5mm *Test times : 6hrs.(Two hrs each in three mutually perpendicular directions)	No mechanical damage. Samples shall satisfy electrical specification after test.
High temperature JIS C 0021	*Temperature : 85°C±2°C *Test duration : 1000+24/-0 hours Measurement to be made after keeping at room temperature for 24±2 hrs	No mechanical damage. Samples shall satisfy electrical specification after test.
Humidity (steady conditions) JIS C 0022	*Humidity : 90% to 95% R.H. *Temperature : 40±2°C *Time : 1000+24/-0 hrs. Measurement to be made after keeping at room temperature for 24±2 hrs ※ 500hrs measuring the first data then 1000hrs data	No mechanical damage. Samples shall satisfy electrical specification after test.
Low temperature JIS C 0020	*Temperature : -40°C±2°C *Test duration : 1000+24/-0 hours Measurement to be made after keeping at room temperature for 24±2 hrs	No mechanical damage. Samples shall satisfy electrical specification after test.

SOLDERING CONDITION

Typical examples of soldering processes that provide reliable joints without any damage are given in Fig 2

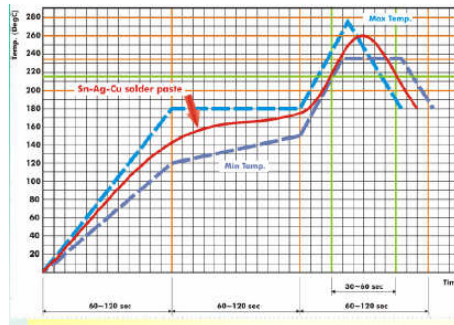

UNLESS OTHER SPECIFIED TOLERANCES ON : X=N/A X.X=N/A X.XX=N/A ANGLES=N/A HOLEDIA=N/A		 INPAQ TECHNOLOGY CO., LTD.
SCALE : N/A	UNIT : mm	
DRAWN BY : 詹惠雯	CHECKED BY : 詹惠雯	THIS DRAWINGS AND SPECIFICATIONS ARE THE PROPERTY OF INPAQ TECHNOLOGY CO.,LTD.AND SHALL NOT BE REPRODUCED OR USED AS THE BASIS FOR THE MANUFACTURE OR SALE OF APPARATUS OR DEVICES WITHOUT PERMISSION
DESIGNED BY : 黃瑞郎	APPROVED BY : 陳振榮	
TITLE : ACA-2012-P1-CC-S		DOCUMENT NO. ENS070001760-000824000157
		SPEC REV. A0

6. Package

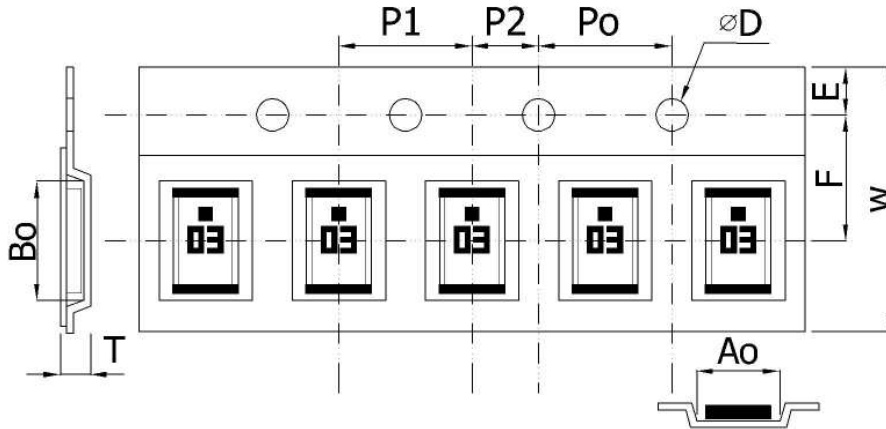

Plastic Tape specifications (unit :mm)

Index	Ao	Bo	ΦD	T	W
Dimension (mm)	1.40 ± 0.10	2.25 ± 0.10	1.55 ± 0.05	0.75 ± 0.10	8.20 ± 0.30
Index	E	F	Po	P1	P2
Dimension (mm)	1.75 ± 0.10	3.50 ± 0.05	4.00 ± 0.10	4.00 ± 0.10	2.00 ± 0.10

Reel dimensions

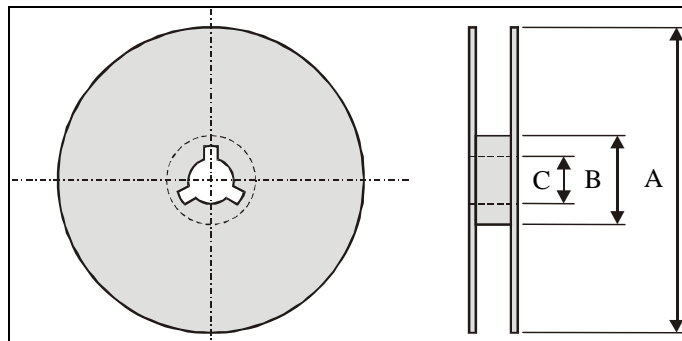

Index	A	B	C
Dimension (mm)	Φ178.0	Φ60.0	Φ13.0

Taping Quantity:2000 pieces per 7" reel

UNLESS OTHER SPECIFIED TOLERANCES ON : X=N/A X.X=N/A X.XX=N/A ANGLES=N/A HOLEDIA=N/A		 INPAQ TECHNOLOGY CO., LTD.
SCALE : N/A	UNIT : mm	
DRAWN BY : 詹惠雯	CHECKED BY : 詹惠雯	THIS DRAWINGS AND SPECIFICATIONS ARE THE PROPERTY OF INPAQ TECHNOLOGY CO.,LTD.AND SHALL NOT BE REPRODUCED OR USED AS THE BASIS FOR THE MANUFACTURE OR SALE OF APPARATUS OR DEVICES WITHOUT PERMISSION
DESIGNED BY : 黃瑞郎	APPROVED BY : 陳振榮	
TITLE : ACA-2012-P1-CC-S		DOCUMENT NO. ENS070001760-000824000157
		SPEC REV. A0