

Figure 1

### 1. INTRODUCTION

This instruction sheet covers assembling a terminated contact, housing and TPA as represented in Figure 1 and extracting the contacts from the housing.

Reasons for reissue of this instruction sheet are provided in Section 6, REVISION SUMMARY.



**NOTE**  
*Dimensions in these instructions are in metric units [with inches in brackets]. Figures and illustrations are for reference only and are not drawn to scale.*

### 2. DESCRIPTION

All VAL-U-LOK pin and socket contacts have two flexible latches that lock into their respective housings when fully inserted. The TPA-compatible contacts have special features on their insulation barrels that work in conjunction with the TPA device to ensure full contact insertion. See Figure 2A.

The plug and receptacle housings are available in 2 through 24 positions which are arranged into 2 rows. The TPA devices are available in 1 through 12 positions, single row, so 2 TPA devices are required for each housing. The TPA is designed to be installed into the housing to ensure all contacts are fully inserted and will not back out during mating. When fully installed, the locking latches of the TPA snap onto raised ledges around the perimeter of the housing. See Figure 3B.

### 3. ASSEMBLY

1. Ensure that the contact is properly terminated to the wire according to the requirements provided in Application Specification 114-13172. Check that the flexible latches are not damaged or distorted from their original form as shown in Figure 2A.

2. Insert the terminated contact into its respective housing as follows:

- a. Grasp the contact directly behind the insulation barrel. Align the contact with a contact cavity in the housing at the wire entry end as shown in Figure 2A. Make sure that the contact is perfectly aligned (not angled or rotated) to the contact cavity. See Figure 2B.

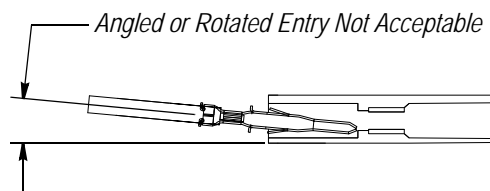
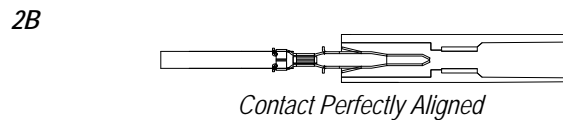
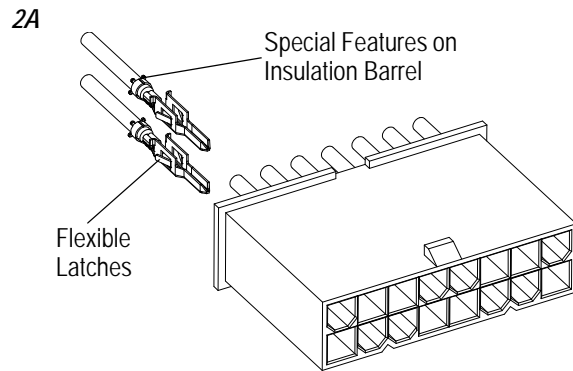

Figure 2



**CAUTION**

Never insert the contact upside down; otherwise, the locking latches could depress and lodge into the cavity in an unseated position or become compressed so that they will not lock when repositioned for proper insertion.

b. Push the contact straight, not rotated, into the contact cavity. If it is rotated, damage to the contact will occur or the contact will not latch properly into the contact cavity. See Figure 2B. Do not force the contact into the housing. It should slide in and latch into position with minimal force.

c. Ensure that the contact latches are locked into the cavity by pulling lightly on the wire and checking for resistance to pull out.

3. Install the TPAs into the housing as follows:

a. Align a TPA with the wire end of the housing so that each tooth faces a contact cavity with its radius surface against the wire. See Figure 3A.

b. Slide the TPA into the housing so that the teeth enter the contact cavities evenly and until all the locking latches lock onto the ledges around the perimeter of the housing. Make sure to push on each locking latch individually to ensure complete installation. There will be an audible and tactile “click”. See Figure 3B.



**NOTE**

TPAs with more than 5 positions have 4 locking latches. TPAs with 5 positions or less have only 2 locking latches. Make sure to push on each locking latch individually to ensure complete installation.

c. Flip the housing over and repeat steps “3a” and “3b” with a second TPA for the other row.

**4. EXTRACTING CONTACTS**

1. TPAs can be removed from the housing by releasing the locking latches from the ledges and pulling the TPA straight away from the housing. No contact can be extracted until the TPA is removed.

2. Contacts can be removed from housings using Extraction Tool 1586343-1 according to Instruction Sheet 408-32114.



**CAUTION**

DO NOT re-insert any extracted contacts.

**5. REPLACEMENT AND REPAIR**

- DO NOT use defective or damaged products. Contacts, housings, and TPAs are not repairable.
- DO NOT re-use a contact by removing the wire.
- DO NOT re-insert any contact after extracting it from the receptacle housing.

**6. REVISION SUMMARY**

- Initial release of document

3A

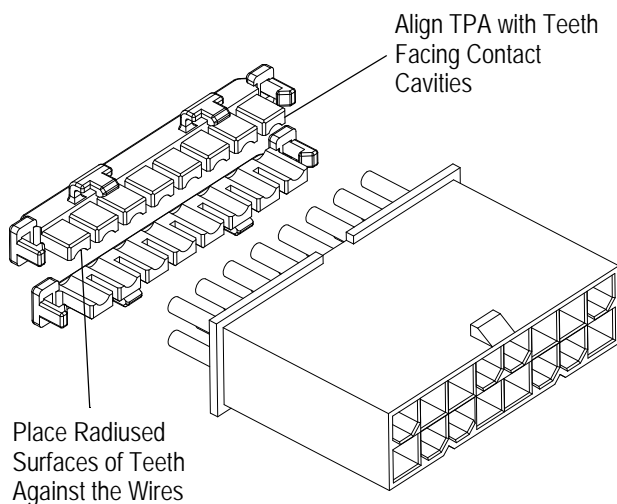

3B

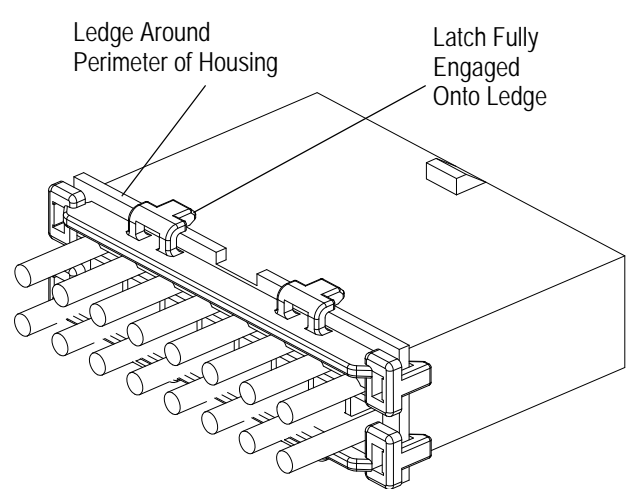

Figure 3