

MATERIALS

HOUSING: LCP (UL 94V-0), BLACK
 SHELL: STAINLESS STEEL
 PAD: STAINLESS STEEL, GOLD FLASH
 TERMINAL: PHOSPHOR BRONZE, GOLD PLATED ON CONTACT AREA, TIN PLATING ON SOLDER TAIL

SPECIFICATION

CURRENT RATING: 0.5AMP MAX
 DIELECTRIC WITHSTANDING: 500V AC FOR ONE MINUTE
 CONTACT RESISTANCE: 100m OHMS MAX
 INSULATION RESISTANCE: 1000M OHMS AT DC 500V
 OPERATION TEMPERATURE: -25°C~+85°C
 COPLANARITY OF SOLDER TAILS: 0.10mm MAX

RoHS Compliant		HSM 玄茂科技股份有限公司 HSUAN MAO TECHNOLOGY CO., LTD.	
APPD 核准 Betty	SCALE 比例 参考	TOLERANCE 容許公差 0 ± 0.30 .00 ± 0.20 ANG. ± 3°	PART NAME 品名 TFLASH+SIM CARD SMT TYPE 16P SELECTIVE GOLD 5U" PLATING BLACK COLOR REEL PACKING ROHS
DWG. 製圖 Betty	UNIT 單位 MM	SIZE 紙張尺寸 A 4	PART NO. C0633-16DEBR00R
DATE 制表日 2013/08/20	PAGE 版數 1 OF 4	REV. 版次 A	料號

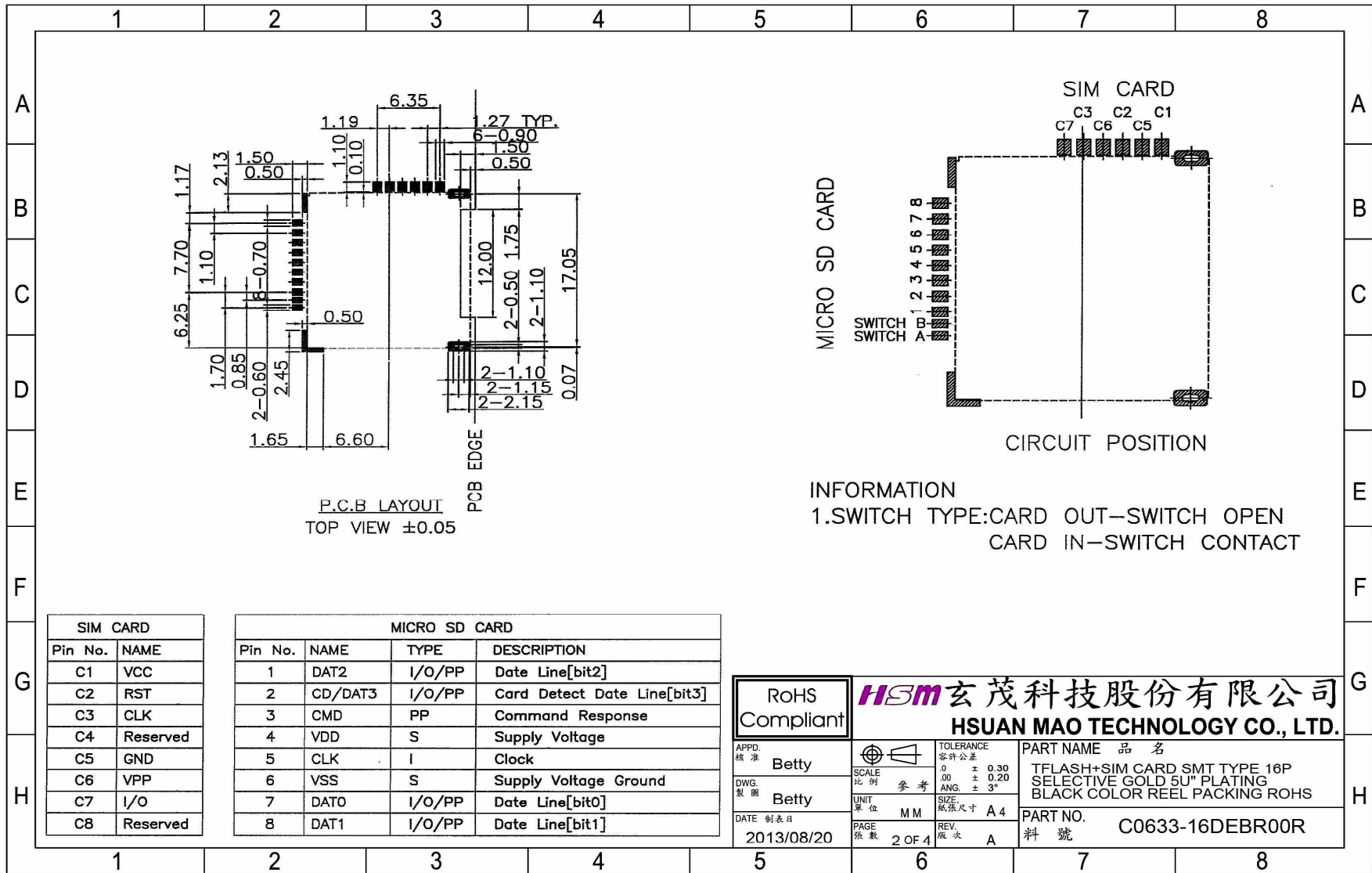

P.C.B LAYOUT
TOP VIEW ±0.05

MICRO SD CARD

SIM CARD

INFORMATION
1.SWITCH TYPE: CARD OUT-SWITCH OPEN
CARD IN-SWITCH CONTACT

SIM CARD	
Pin No.	NAME
C1	VCC
C2	RST
C3	CLK
C4	Reserved
C5	GND
C6	VPP
C7	I/O
C8	Reserved

MICRO SD CARD			
Pin No.	NAME	TYPE	DESCRIPTION
1	DAT2	I/O/PP	Date Line[bit2]
2	CD/DAT3	I/O/PP	Card Detect Date Line[bit3]
3	CMD	PP	Command Response
4	VDD	S	Supply Voltage
5	CLK	I	Clock
6	VSS	S	Supply Voltage Ground
7	DAT0	I/O/PP	Date Line[bit0]
8	DAT1	I/O/PP	Date Line[bit1]

		玄茂科技股份有限公司 HSUAN MAO TECHNOLOGY CO., LTD.	
APPD. 核准 Betty	SCALE 比例 参考	TOLERANCE 容許公差 0 ± 0.30 .00 ± 0.20 ANG. ± 3°	PART NAME 品名 TFLASH+SIM CARD SMT TYPE 16P SELECTIVE GOLD 5U" PLATING BLACK COLOR REEL PACKING ROHS
DWG. 製圖 Betty	UNIT 單位 MM	SIZE 紙張尺寸 A 4	PART NO. 料號 C0633-16DEBR00R
DATE 制表日 2013/08/20	PAGE 張數 2 OF 4	REV. 版次 A	

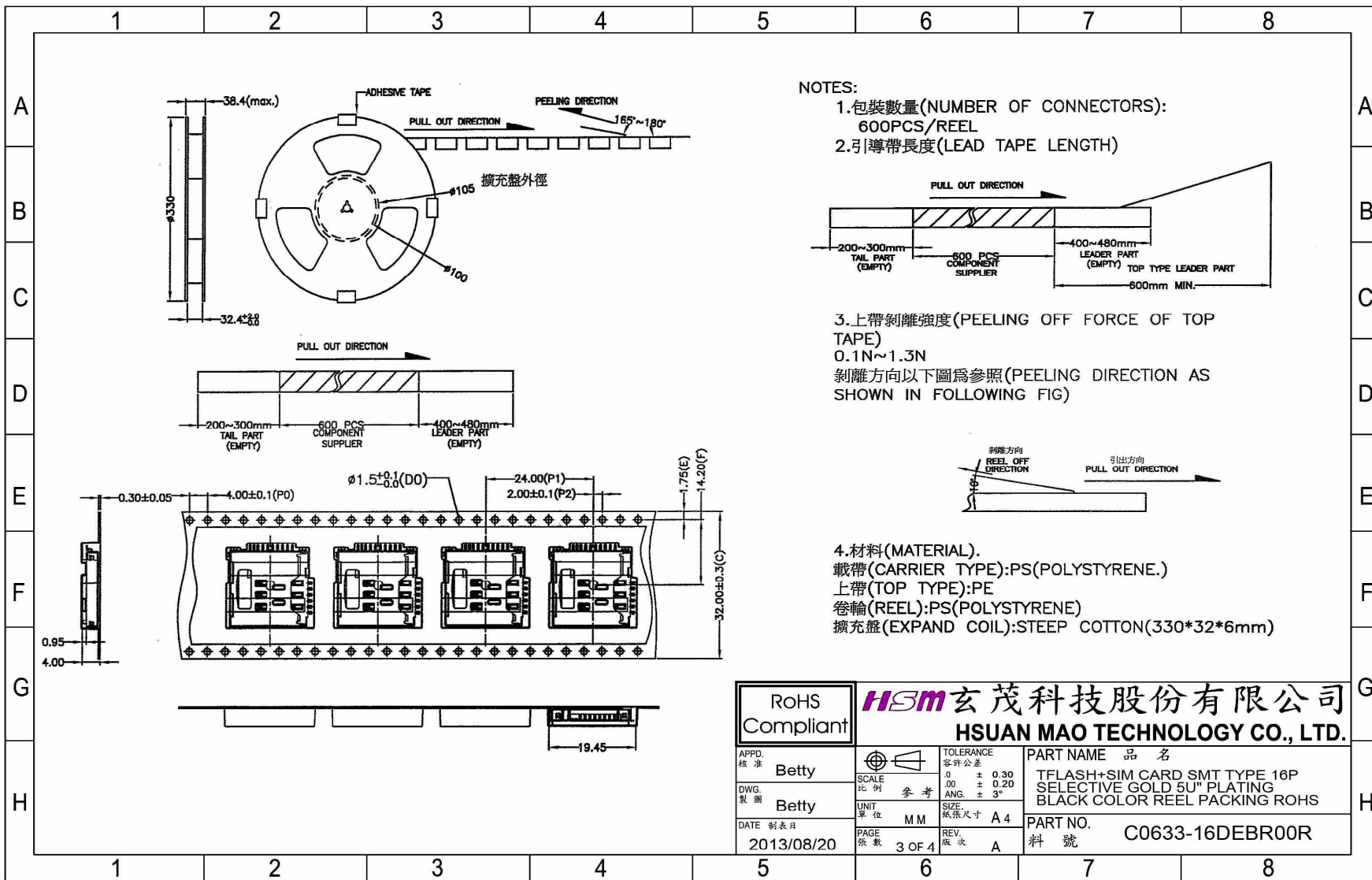

NOTES:

- 1.包裝數量(NUMBER OF CONNECTORS): 600PCS/REEL
- 2.引導帶長度(LEAD TAPE LENGTH)

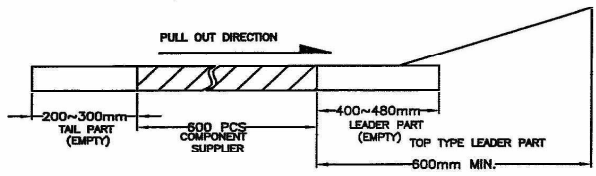

- 3.上帶剝離強度 (PEELING OFF FORCE OF TOP TAPE) 0.1N~1.3N
- 剝離方向以下圖為參照 (PEELING DIRECTION AS SHOWN IN FOLLOWING FIG)

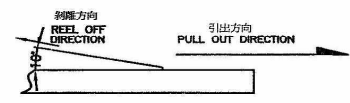

- 4.材料 (MATERIAL):
- 載帶 (CARRIER TYPE): PS (POLYSTYRENE.)
- 上帶 (TOP TYPE): PE
- 卷輪 (REEL): PS (POLYSTYRENE)
- 擴充盤 (EXPAND COIL): STEEP COTTON (330*32*6mm)

RoHS Compliant		HSM 玄茂科技股份有限公司 HSUAN MAO TECHNOLOGY CO., LTD.	
APPD. 核准 Betty	SCALE 比例 參考	TOLERANCE 容許公差 0 ± 0.30 .00 ± 0.20 ANG. ± 3°	PART NAME 品名 TFLASH+SIM CARD SMT TYPE 16P SELECTIVE GOLD 5U" PLATING BLACK COLOR REEL PACKING ROHS
DWG. 製圖 Betty	UNIT 單位 MM	SIZE 紙張尺寸 A 4	PART NO. C0633-16DEBR00R
DATE 制表日 2013/08/20	PAGE 版數 3 OF 4	REV. 版次 A	料號

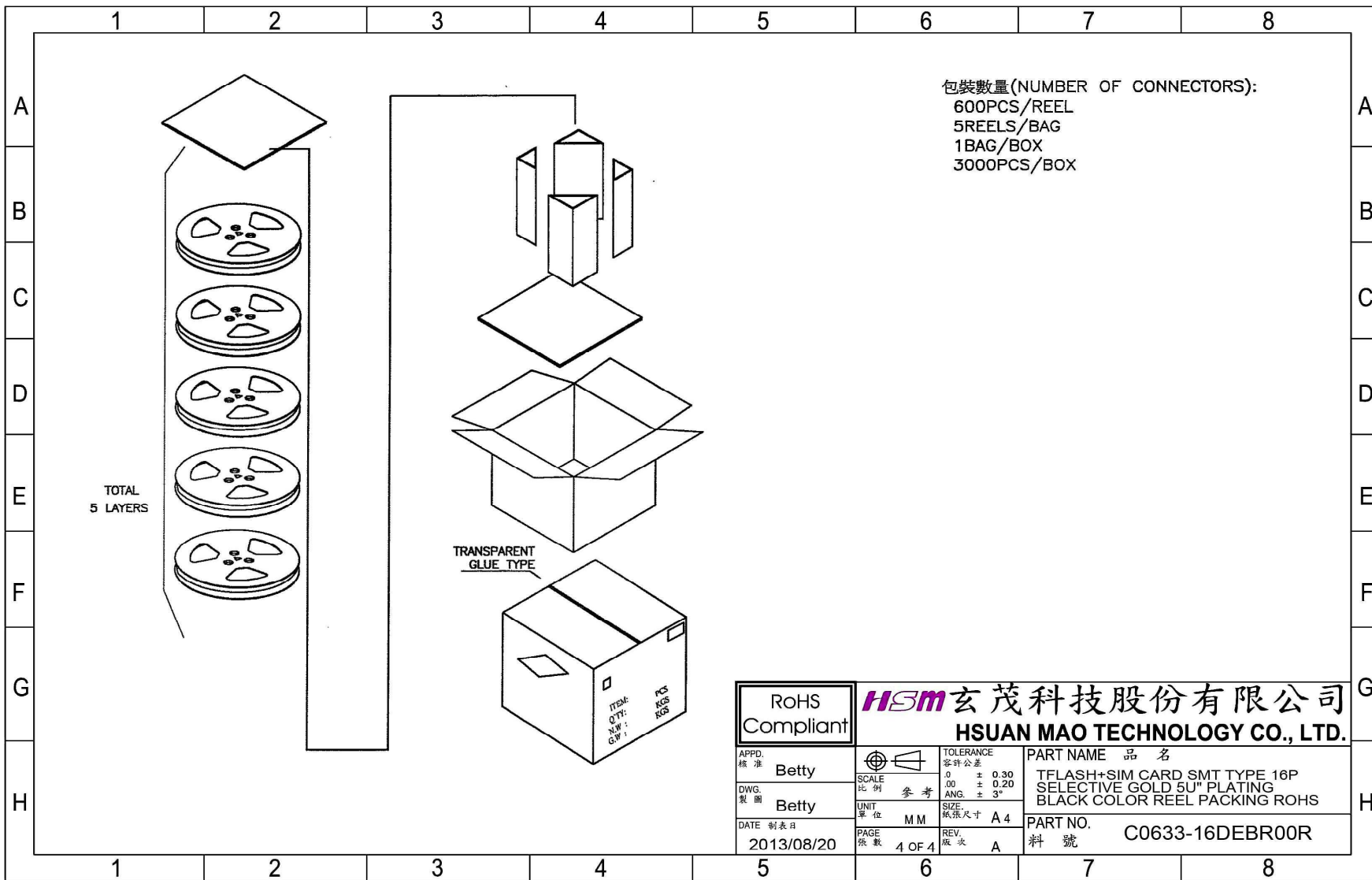

包裝數量(NUMBER OF CONNECTORS):
 600PCS/REEL
 5REELS/BAG
 1BAG/BOX
 3000PCS/BOX

RoHS Compliant		HSM 玄茂科技股份有限公司 HSUAN MAO TECHNOLOGY CO., LTD.	
APPD. 核准 Betty	SCALE 比例 參考	TOLERANCE 容許公差 0 ± 0.30 .00 ± 0.20 ANG. ± 3°	PART NAME 品名 TFLASH+SIM CARD SMT TYPE 16P SELECTIVE GOLD 5U" PLATING BLACK COLOR REEL PACKING ROHS
DWG. 製圖 Betty	UNIT 單位 MM	SIZE 紙張尺寸 A 4	PART NO. 料號 C0633-16DEBR00R
DATE 制表日 2013/08/20	PAGE 張數 4 OF 4	REV. 版次 A	