

MATERIAL&FINISHES:
BODY/HOOK :BRASS/PLATED GOLD 1μ MICROINCH MIN.

MALE CONTACT/SIDE CONTACT:BRASS
PLATED GOLD 10μ MICROINCH MIN.

FEMALE CONTACT:PHOSPHOR BRONZE
PLATED GOLD 10μ MICROINCH MIN.

INSULATOR:TEFLON
COLOR NATURE

SPRING :STAINLESS STEEL

JUM NUT :BRASS
/ PLATED GOLD 1μ MICROINCH MIN.

LOCK WASHER :PHOSPHOR BRONZE
PLATED GOLD 1μ MICROINCH MIN.

PACKING :
73391-1120 BY TRAY
NUT/WASHER BY POLY BAG

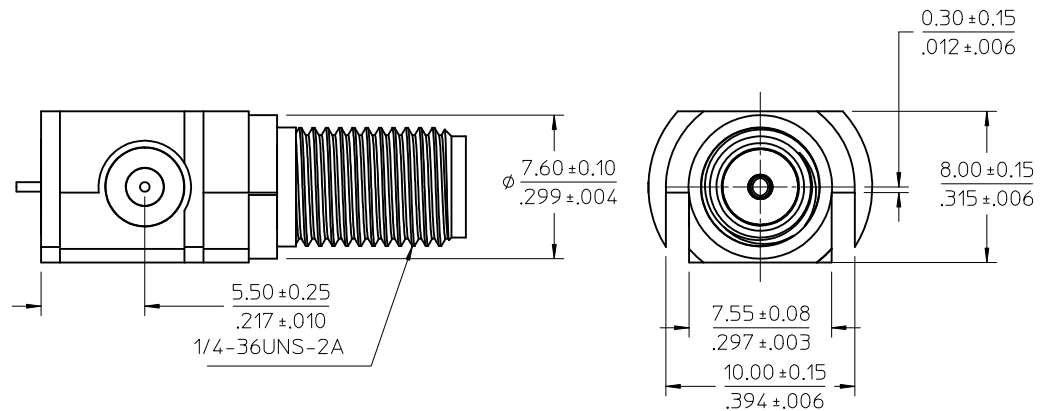
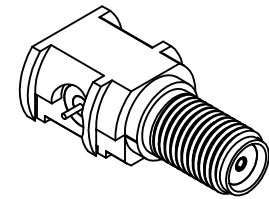
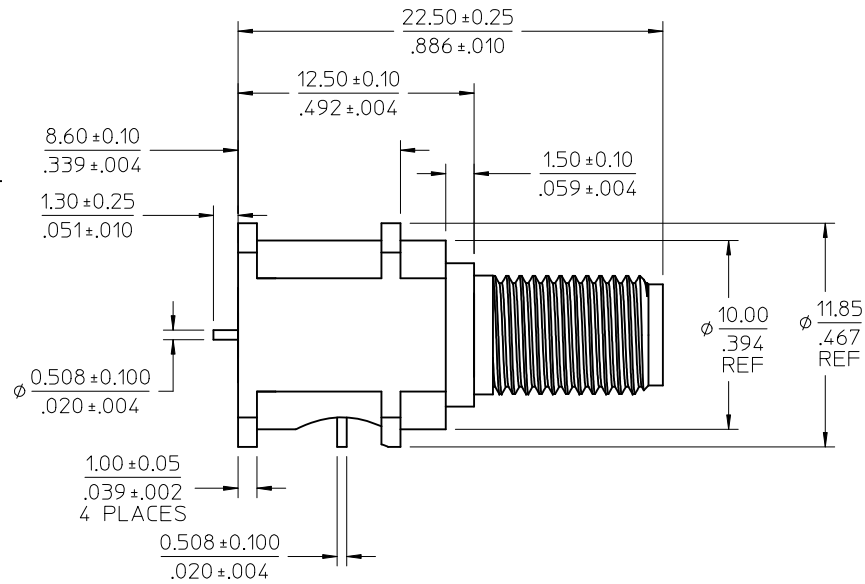

PS-73398-047	EE/MECH PERFORMANCE
SPECIFICATION	DESCRIPTION

CHG:1ADD TEFLON
COLOR NATURE
2ADD WASHER AND
NUT DIMENSION AND
CUSTOMER REQUEST
EC NO: URF2011-0205
DRAWN:CHENG 2010/10/04
CHKD:
APPR:MHUANG 2010/10/13

QUALITY SYMBOLS
▽=0
▽=0

GENERAL TOLERANCES (UNLESS SPECIFIED)

	mm	INCH
4 PLACES	± .10	± .004
3 PLACES	± .13	± .005
2 PLACES	± 0.13	± .005
1 PLACE	± 0.25	± .010

ANGULAR ± 2°

DRAFT WHERE APPLICABLE
MUST REMAIN
WITHIN DIMENSIONS

DIMENSION STYLE
MM/IN

DRAWN BY DATE
DARRY 2008/4/30

CHECKED BY DATE
JOHNSON 2008/4/30

APPROVED BY DATE
MHUANG 2010/10/13

MATERIAL NO.
733911120

SIZE
C

SCALE
DESIGN UNITS
METRIC

THIRD ANGLE PROJECTION

TITLE
SMA JACK SWITCH SMT TYPE
SAM-J/SMT

MOLEX INCORPORATED

DOCUMENT NO.
SD-73391-112

SHEET NO.
1 OF 4

THIS DRAWING CONTAINS INFORMATION THAT IS PROPRIETARY TO MOLEX INCORPORATED AND SHOULD NOT BE USED WITHOUT WRITTEN PERMISSION

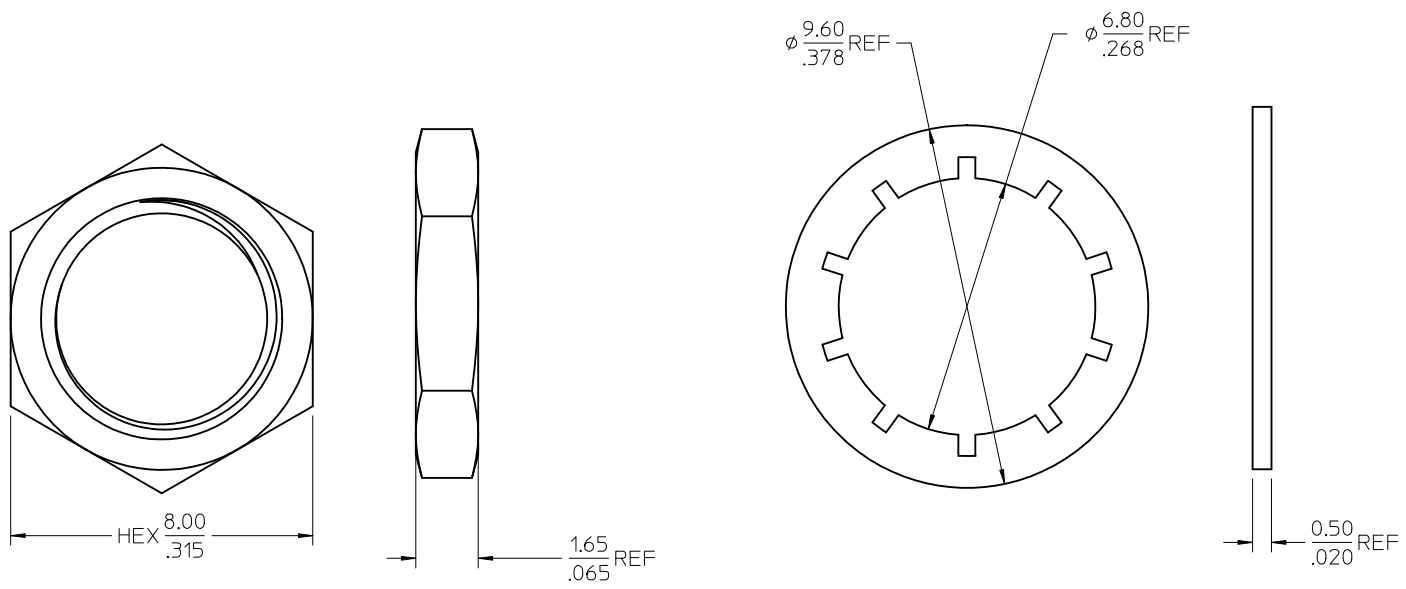

CHG: SEE SHEET 1
 EC NO: URF2011-0205 2010/10/04
 DRWN: YCHENG
 CHKD: APPR: MHUANG 2010/10/13

REV	DESCRIPTION
D	

QUALITY SYMBOLS	
	=0
	=0

GENERAL TOLERANCES (UNLESS SPECIFIED)	
	MM/IN
4 PLACES	± .13 / ± .005
3 PLACES	± .13 / ± .005
2 PLACES	± 0.13 / ± .005
1 PLACE	± 0.25 / ± .010
ANGULAR ± 2 °	

DIMENSION STYLE		SCALE	DESIGN UNITS	THIRD ANGLE PROJECTION
MM/IN			METRIC	
DRAWN BY	DATE	TITLE		
DARRY	2008/4/30	SMA JACK SWITCH SMT TYPE SAM-J/SMT		
CHECKED BY	DATE	MOLEX INCORPORATED		
JOHNSON	2008/4/30			
APPROVED BY	DATE	DOCUMENT NO.	SHEET NO.	
MHUANG	2010/10/13	SD-73391-112	2 OF 4	
MATERIAL NO.		THIS DRAWING CONTAINS INFORMATION THAT IS PROPRIETARY TO MOLEX INCORPORATED AND SHOULD NOT BE USED WITHOUT WRITTEN PERMISSION		
SEE SHEET 1				

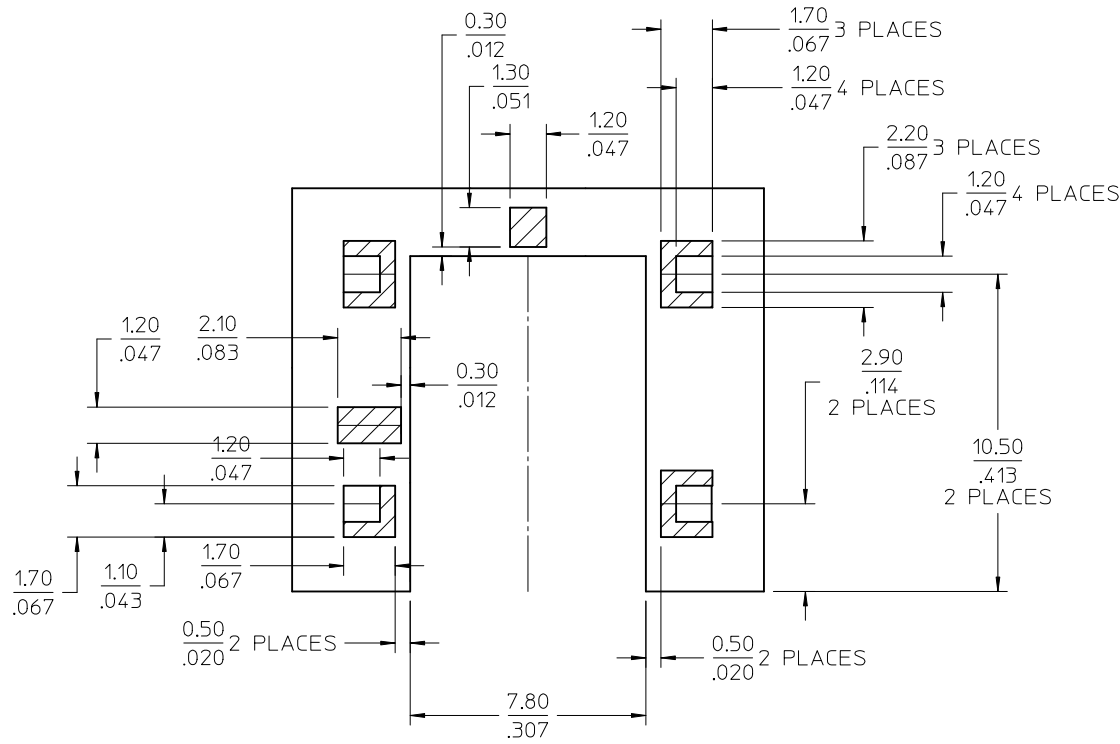

PCB FRONT VIEW

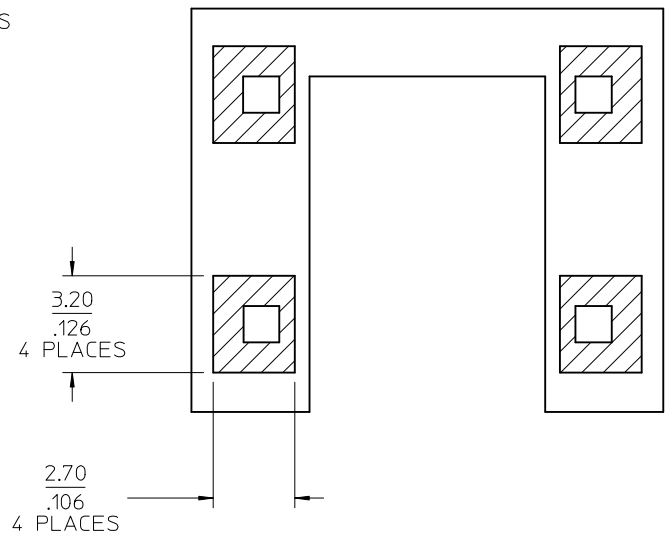

PCB BACK VIEW

RECOMMEND PCB LAYOUT DIMENSION

CHG: SEE SHEET 1

EC NO: URF2011-0205 2010/10/04

DRWN: YCHENG

CHKD: APPR: MHUANG 2010/10/13

REV DESCRIPTION

QUALITY SYMBOLS

▽=0

▽=0

GENERAL TOLERANCES (UNLESS SPECIFIED)	
mm	INCH
4 PLACES ± .13	± .005
3 PLACES ± .15	± .006
2 PLACES ± 0.13	± .005
1 PLACE ± 0.25	± .010
ANGULAR ± 2°	

DRAFT WHERE APPLICABLE MUST REMAIN WITHIN DIMENSIONS

DIMENSION STYLE	
MM/IN	
DRAWN BY	DATE
DARRY	2008/4/30
CHECKED BY	DATE
JOHNSON	2008/4/30
APPROVED BY	DATE
MHUANG	2010/10/13

SCALE	DESIGN UNITS	THIRD ANGLE PROJECTION
	METRIC	
TITLE		
SMA JACK SWITCH SMT TYPE SAM-J/SMT		
MATERIAL NO.		
SEE SHEET 1		
DOCUMENT NO.		
SD-73391-112		
SHEET NO.		
3 OF 4		



MOLEX INCORPORATED

THIS DRAWING CONTAINS INFORMATION THAT IS PROPRIETARY TO MOLEX INCORPORATED AND SHOULD NOT BE USED WITHOUT WRITTEN PERMISSION

360 mm REF. * 170 mm REF.

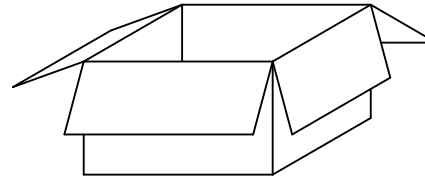
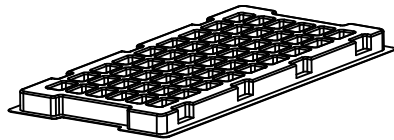
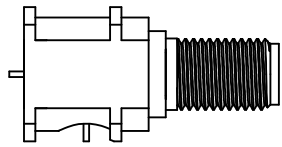

54 PCS PER ONE TRAY

10 TRAYS (540 PCS) IN ONE INNER CARTON BOX

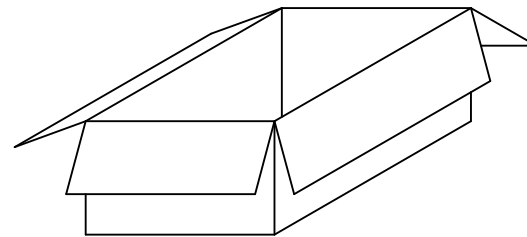

2 INNER CARTON (1080 PCS) IN OUTER CARTON BOX

SEE SHEET 1 EC NO: URF2011-0205 2010/10/04 DRAWN: CHENG CHKD: APPR: MHUANG 2010/10/13 DESCRIPTION	QUALITY SYMBOLS	GENERAL TOLERANCES (UNLESS SPECIFIED) <table border="1"> <tr> <td></td> <td>mm</td> <td>INCH</td> </tr> <tr> <td>4 PLACES</td> <td>± ---</td> <td>± ---</td> </tr> <tr> <td>3 PLACES</td> <td>± ---</td> <td>± ---</td> </tr> <tr> <td>2 PLACES</td> <td>± 0.13</td> <td>± ---</td> </tr> <tr> <td>1 PLACE</td> <td>± 0.25</td> <td>± ---</td> </tr> </table> ANGULAR ± 2 ° DRAFT WHERE APPLICABLE MUST REMAIN WITHIN DIMENSIONS		mm	INCH	4 PLACES	± ---	± ---	3 PLACES	± ---	± ---	2 PLACES	± 0.13	± ---	1 PLACE	± 0.25	± ---	DIMENSION STYLE	SCALE	DESIGN UNITS	THIRD ANGLE PROJECTION
			mm	INCH																	
	4 PLACES		± ---	± ---																	
	3 PLACES		± ---	± ---																	
2 PLACES	± 0.13	± ---																			
1 PLACE	± 0.25	± ---																			
	MM/IN		METRIC																		
	DRAWN BY DATE	CHECKED BY DATE	TITLE																		
	DARRY 2008/4/30	JOHNSON 2008/4/30	SMA JACK SWITCH SMT TYPE SAM-J/SMT																		
	APPROVED BY DATE	MATERIAL NO.	MOLEX INCORPORATED																		
	MHUANG 2010/10/13	SEE SHEET 1	DOCUMENT NO. SD-73391-112																		
		SIZE	SHEET NO. 4 OF 4																		
			THIS DRAWING CONTAINS INFORMATION THAT IS PROPRIETARY TO MOLEX INCORPORATED AND SHOULD NOT BE USED WITHOUT WRITTEN PERMISSION																		