

WG160128C Graphic 160 x 128 dots

Dimension drawing

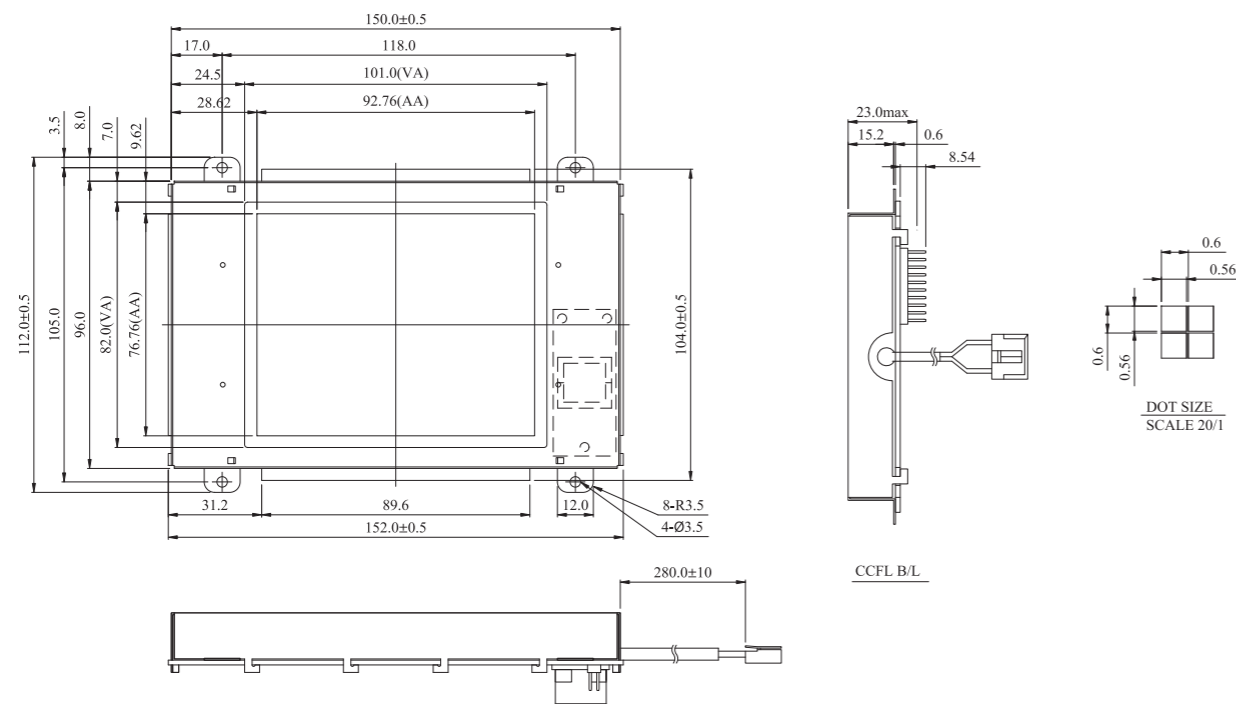

WG160128E Graphic 160x128dots

Dimension drawing

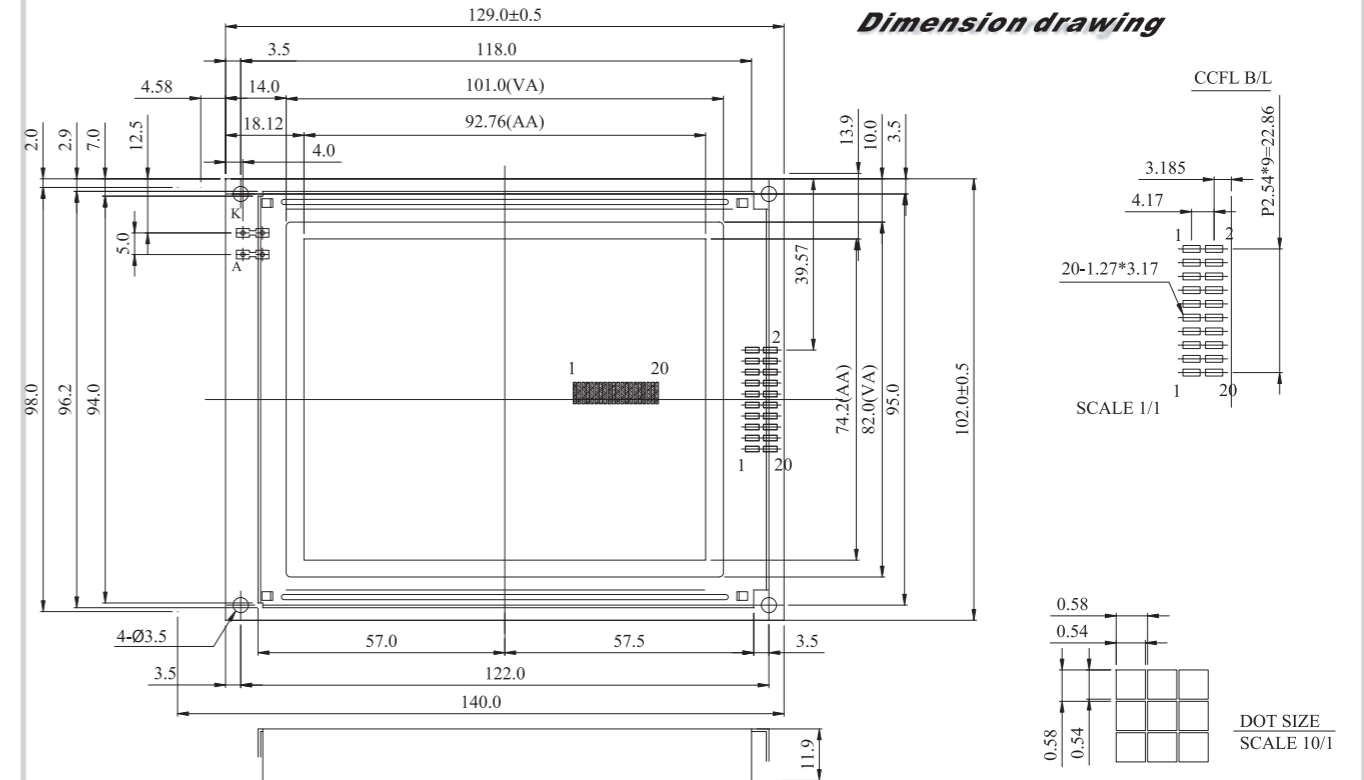

Graphic type

Feature

1. Built-in controller TOSHIBA- (T6963C or equivalent)
2. +5V power supply
3. 1/128 duty cycle
4. Optional N/v
5. Built in CCFL Inverter

Mechanical Data

Item	Standard Value	Unit
Module Dimension	150.0x112.0	mm
Viewing Area	101.0x82.0	mm
Dot Size	0.56x0.56	mm
Dot Pitch	0.60x0.60	mm
Mounting hole	118.0x105.0	

Absolute Maximum Rating

Item	Symbol	Standard Value			Unit
		min.	typ.	max.	
Power Supply	VDD-VSS	4.75	5.0	5.25	V
Input Voltage	VI	-0.3	---	VDD	V

Note : VSS=0 Volt, VDD=5.0 Volt.

Electronical Characteristics

Item	Symbol	Condition	Standard Value			Unit
			min.	typ.	max.	
Input Voltage	VDD	L level	0.7V _{DD}	---	V _{DD}	V
	VIO	H level	0	---	0.3V _{DD}	V
Supply Current	IDD	VDD=+5V	---	4.5	50	mA
Recommended LC Driving Voltage for Normal Temp. Version module	VDD-V0	-20°C	19.9	21.0	22.1	V
		0°C	19.0	---	21.2	
		25°C	18.6	19.1	19.6	
		50°C	16.2	16.5	16.8	
		70°C	11.6	9.1	12.8	
CCFL Forward Voltage	VF	25°C	---	256	560	V
CCFL Forward Current	IF	25°C	---	---	5.0	mA

Pin NO.	Symbol	Function
1	FGND	Frame Ground
2	VSS	Power Supply(GND)
3	Vdd	Power supply (+5V)
4	Vadj	Contrast Adjustment
5	Vee	Negative Voltage output
6	WR	Data Write
7	RD	Data read
8	CE	Chip enable
9	C/D	Command/ Data read/write
10	HALT	Clock operating stop signal
11	Reset	Reset signal
12	DB0	Data bus line
13	DB1	Data bus line
14	DB2	Data bus line
15	DB3	Data bus line
16	DB4	Data bus line
17	DB5	Data bus line
18	DB6	Data bus line
19	DB7	Data bus line
20	NC	No connection

Feature

1. Built in controller Tosiba- (T6963C or equivalent)
2. +5V power supply
3. 1/128 duty cycle
4. Optional N/V
5. View angle 12°H only.

Pin NO.	Symbol	Function
1	FG	Frame ground
2	Vss	Power supply(GND)
3	Vdd	Power supply (+5V)
4	Vadj	Contrast Adjustment
5	Vee	Negative Voltage output
6	WR	Data write
7	RD	Data read
8	CE	Chip enable
9	C/D	Command /data read/write
10	HALT	Clock operating stop signal
11	Reset	Reset signal
12	DB0	Data bus line
13	DB1	Data bus line
14	DB2	Data bus line
15	DB3	Data bus line
16	DB4	Data bus line
17	DB5	Data bus line
18	DB6	Data bus line
19	DB7	Data bus line
20	NC	No connection

Mechanical Data

Item	Standard Value	Unit
Module Dimension	129.0x102.0	mm
Viewing Area	101.0x82.0	mm
Dot Size	0.54x0.54	mm
Dot pitch	0.58x0.58	mm
Mounting hole	122.0x96.2	mm

Absolute Maximum Rating

Item	Symbol	Standard Value			Unit
		min.	typ.	max.	
Power Supply	VDD-VSS	4.75	5.0	5.25	V
Input Voltage	VI	-0.3	---	VDD	V

Note : VSS=0 Volt, VDD=5.0 Volt.

Electronical Characteristics

Item	Symbol	Condition	Standard Value			Unit
			min.	typ.	max.	
Input Voltage	VDD	L level	0.7V _{DD}	---	V _{DD}	V
	VIO	H level	0	---	0.3V _{DD}	V
Supply Current	IDD	VDD=+5V	---	45	50	mA
Recommended LC Driving Voltage for Normal Temp. Version module	VDD-V0	-20°C	19.9	21.0	22.1	V
		0°C	19.0	---	21.2	
		25°C	18.6	19.1	19.6	
		50°C	16.2	16.5	16.8	
		70°C	11.6	9.1	12.8	
CCFL Forward Voltage	VF	25°C	---	256	560	Vrms
CCFL Forward Current	IF	25°C	---	---	5.0	mA
LED Forward Voltage	VF	25°C	---	4.6	4.6	V
LED Forward Current	IF	25°C	---	---	500	mA

Graphic type