

# Winstar Display Co., LTD

|                 |                       |              |
|-----------------|-----------------------|--------------|
| <b>CUSTOMER</b> |                       |              |
| <b>MODEL</b>    | <b>WG12864A-YGK-V</b> |              |
| <b>APPROVAL</b> | <b>BY:</b>            | <b>DATA:</b> |

| <b>SALES BY</b> | <b>APPROVED BY</b> | <b>CHECKED BY</b> | <b>PREPARED BY</b> |
|-----------------|--------------------|-------------------|--------------------|
|                 |                    |                   |                    |

**華凌光電股份有限公司**

住址：台中市中清路 163 號  
NO.163 CHUNG CHING RD.  
TAICHUNG, TAIWAN, R.O.C

# Contents

- 1.Module Classification Information
- 2.Precautions in use of LCD Modules
- 3.General Specification
- 4.Absolute Maximum Ratings
- 5.Electrical Characteristics
- 6.Optical Characteristics
- 7.Interface Description
- 8.Contour Drawing & Block Diagram
9. Timing Characteristics
- 10.Display Control Instruction
- 11.Detailed Explanation
- 12.Quality Assurance
- 13.Reliability
- 14.Backlight Information

# 1.Module Classification Information

W G   1 2 8 6 4   A - Y G K -   V  
 ① ②                    ③                    ④ ⑤ ⑥ ⑦                    ⑧

① Brand : WINSTAR DISPLAY CORPORATION

② Display Type : H→ Character Type, G→ Graphic Type

③ Display Font : Character 128 words, 64Lines.

④ Model serials no.

⑤ Backlight Type :    N→ Without backlight  
                                   B→ EL, Blue green                    A→ LED, Amber  
                                   D→ EL, Green                            R→ LED, Red  
                                   W→ EL, White                            O→ LED, Orange  
                                   F→ CCFL, White                        G→ LED, Green  
                                   Y→ LED, Yellow Green

⑥ LCD Mode :            B→ TN Positive, Gray                    T→ FSTN Negative  
                                   N→ TN Negative,  
                                   G→ STN Positive, Gray  
                                   Y→ STN Positive, Yellow Green  
                                   M→ STN Negative, Blue  
                                   F→ FSTN Positive

⑦ LCD Polarizer            A→ Reflective, N.T, 6:00                    H→ Transflective, W.T,6:00  
   Type/ Temperature            D→ Reflective, N.T, 12:00                    K→ Transflective, W.T,12:00  
   range/ View                    G→ Reflective, W. T, 6:00                    C→ Transmissive, N.T,6:00  
   direction                        J→ Reflective, W. T, 12:00                    F→ Transmissive, N.T,12:00  
   B→ Transflective, N.T,6:00                    I→ Transmissive, W. T, 6:00  
   E→ Transflective, N.T,12:00                    L→ Transmissive, W.T,12:00

⑧ Special Code            V : Build in Negative Voltage ;

## 2. Precautions in use of LCD Modules

- (1) Avoid applying excessive shocks to the module or making any alterations or modifications to it.
- (2) Don't make extra holes on the printed circuit board, modify its shape or change the components of LCD module.
- (3) Don't disassemble the LCM.
- (4) Don't operate it above the absolute maximum rating.
- (5) Don't drop, bend or twist LCM.
- (6) Soldering: only to the I/O terminals.
- (7) Storage: please storage in anti-static electricity container and clean environment.

## 3. General Specification

| <b>Item</b>          | <b>Dimension</b>                   | <b>Unit</b> |
|----------------------|------------------------------------|-------------|
| Number of Characters | 128 characters x 64 Lines          | -           |
| Module dimension     | 93.0 x 70.0 x 13.6(MAX)            | mm          |
| View area            | 72.0 x 40.0                        | mm          |
| Active area          | 66.52 x 33.24                      | mm          |
| Dot size             | 0.48 x 0.48                        | mm          |
| Dot pitch            | 0.52 x 0.52                        | mm          |
| LCD type             | STN, Positive, Transflective, Gray |             |
| Duty                 | 1/64                               |             |
| View direction       | 12 o'clock                         |             |
| Backlight Type       | LED Yellow Green                   |             |

## 4. Absolute Maximum Ratings

| Item                     | Symbol           | Min | Typ | Max      | Unit |
|--------------------------|------------------|-----|-----|----------|------|
| Operating Temperature    | $T_{OP}$         | -20 | -   | +70      | °C   |
| Storage Temperature      | $T_{ST}$         | -30 | -   | +80      | °C   |
| Input Voltage            | $V_I$            | 0   | -   | $V_{CC}$ | V    |
| Supply Voltage For Logic | $V_{DD}$         | 0   | -   | 67       | V    |
| Supply Voltage For LCD   | $V_{DD}-V_{SS}$  | 0   | -   | 16.7     | V    |
| Supply Voltage For LCD   | $V_{DD}-V_{OUT}$ | -   | 5   | -        | V    |

## 5. Electrical Characteristics

| Item                     | Symbol          | Condition                 | Min         | Typ | Max      | Unit |
|--------------------------|-----------------|---------------------------|-------------|-----|----------|------|
| Supply Voltage For Logic | $V_{DD}-V_{SS}$ | -                         | 4.5         | 5.0 | 5.5      | V    |
| Supply Voltage For LCD   | $V_{DD}-V_0$    | $T_a=-20^{\circ}\text{C}$ | -           | -   | 10.6     | V    |
|                          |                 | $T_a=25^{\circ}\text{C}$  | -           | 9.1 | -        | V    |
|                          |                 | $T_a=+70^{\circ}\text{C}$ | 7.6         | -   | -        | V    |
| Input High Volt.         | $V_{IH}$        | -                         | $0.7V_{DD}$ | -   | $V_{DD}$ | V    |

|                   |          |   |     |    |             |    |
|-------------------|----------|---|-----|----|-------------|----|
| Input Low Volt.   | $V_{IL}$ | - | 0   | -  | $0.3V_{DD}$ | V  |
| Output High Volt. | $V_{OH}$ | - | 2.4 | -  | -           | V  |
| Output Low Volt.  | $V_{OL}$ | - | -   | -  | 0.4         | V  |
| Supply Current    | $I_{DD}$ | - | -   | 18 | -           | mA |

## 6. Optical Characteristics

| Item           | Symbol       | Condition   | Min | Typ | Max | Unit |
|----------------|--------------|-------------|-----|-----|-----|------|
| View Angle     | (V) $\theta$ | $CR \geq 2$ | 10  | -   | 105 | deg  |
|                | (H) $\phi$   | $CR \geq 2$ | -30 | -   | 30  | deg  |
| Contrast Ratio | CR           | -           | -   | 5   | -   | -    |
| Response Time  | T rise       | -           | -   | 200 | 300 | ms   |
|                | T fall       | -           | -   | 200 | 300 | ms   |

**Definition of Operation Voltage ( $V_{op}$ )**

**Definition of Response Time (  $T_r$  ,  $T_f$  )**

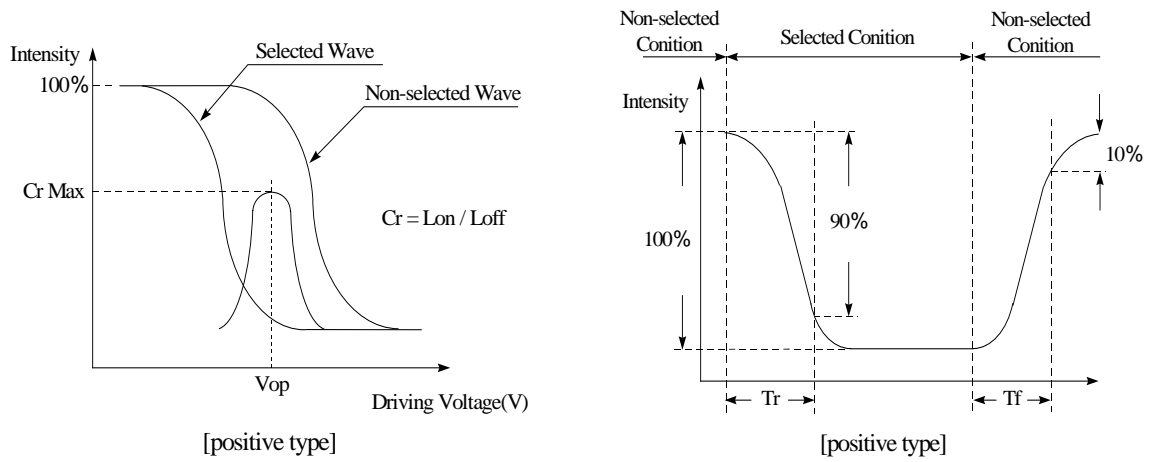

**Conditions :**

Operating Voltage :  $V_{op}$       Viewing Angle( $\theta$  ,  $\varphi$ ) :  $0^\circ$  ,  $0^\circ$

Frame Frequency : 64 HZ      Driving Waveform : 1/N duty , 1/a bias

**Definition of viewing angle( $CR \geq 2$ )**

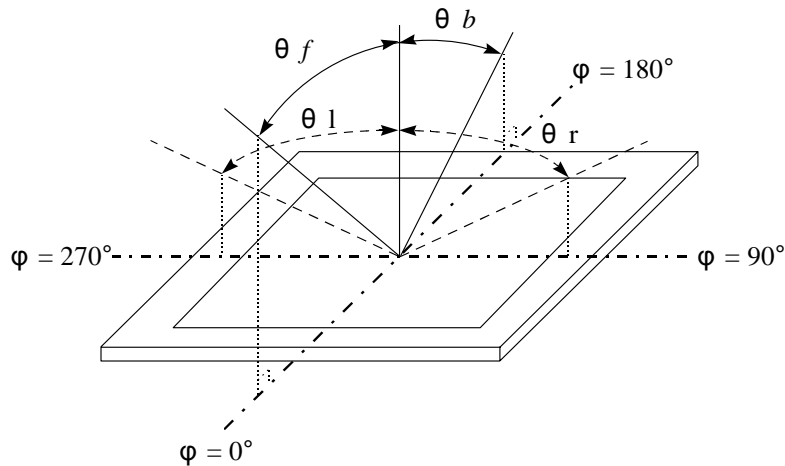

**7. Interface Description**

| Pin No. | Symbol                | Level             | Description   |
|---------|-----------------------|-------------------|---|
| 1       | <b>GND</b>            | <b>0V</b>         | <b>Ground</b>   |
| 2       | <b>V<sub>DD</sub></b> | <b>5.0V</b>       | <b>Supply voltage for logic</b>                       |
| 3       | <b>V<sub>o</sub></b>  | <b>(Variable)</b> | <b>Operating voltage for LCD</b>                      |
| 4       | <b>D/I</b>            | <b>H/L</b>        | <b>H: Data , L : Instruction</b>                      |
| 5       | <b>R/W</b>            | <b>H/L</b>        | <b>H: Read (MPU← Module) , L: Write (MPU→ Module)</b> |
| 6       | <b>E</b>              | <b>H</b>          | <b>Enable signal</b>                                  |
| 7       | <b>DB0</b>            | <b>H/L</b>        | <b>Data bit 0</b>                                     |

|    |      |     |                                    |
|----|------|-----|------------------------------------|
| 8  | DB1  | H/L | Data bit 1                         |
| 9  | DB2  | H/L | Data bit 2                         |
| 10 | DB3  | H/L | Data bit 3                         |
| 11 | DB4  | H/L | Data bit 4                         |
| 12 | DB5  | H/L | Data bit 5                         |
| 13 | DB6  | H/L | Data bit 6                         |
| 14 | DB7  | H/L | Data bit 7                         |
| 15 | CS1  | L   | Select Column 1~ Column 64         |
| 16 | CS2  | L   | Select Column 65~ Column 128       |
| 17 | RST  | L   | Reset signal                       |
| 18 | Vout | -   | Negative Voltage                   |
| 19 | A    | -   | Power Supply for LED backlight (+) |
| 20 | K    | -   | Power Supply for LED backlight (-) |

## 8. Contour Drawing & Block Diagram



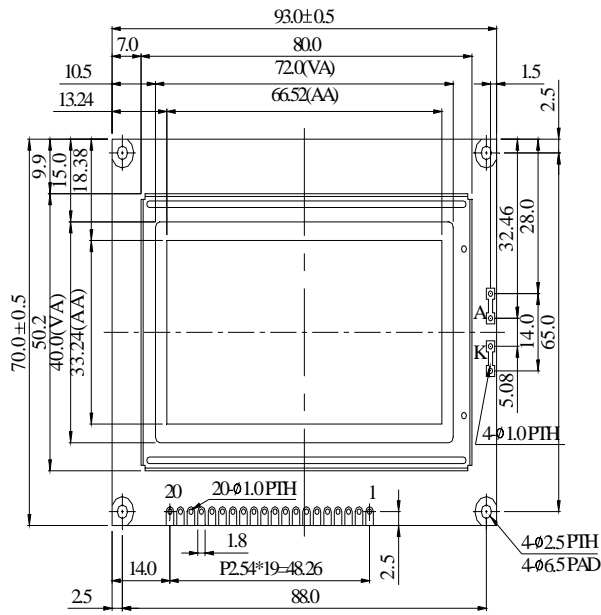

LEDBL

| PIN NO. | SYMBOL |
|---------|--------|
| 1       | Vss    |
| 2       | Vdd    |
| 3       | Vo     |
| 4       | DI     |
| 5       | R/W    |
| 6       | E      |
| 7       | DB0    |
| 8       | DB1    |
| 9       | DB2    |
| 10      | DB3    |
| 11      | DB4    |
| 12      | DB5    |
| 13      | DB6    |
| 14      | DB7    |
| 15      | CS1    |
| 16      | CS2    |
| 17      | RES    |
| 18      | Vout   |
| 19      | A      |
| 20      | K      |

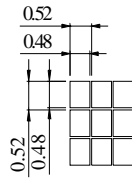

DOT SIZE

The non-specified tolerance of dimension is  $\pm 0.3\text{mm}$

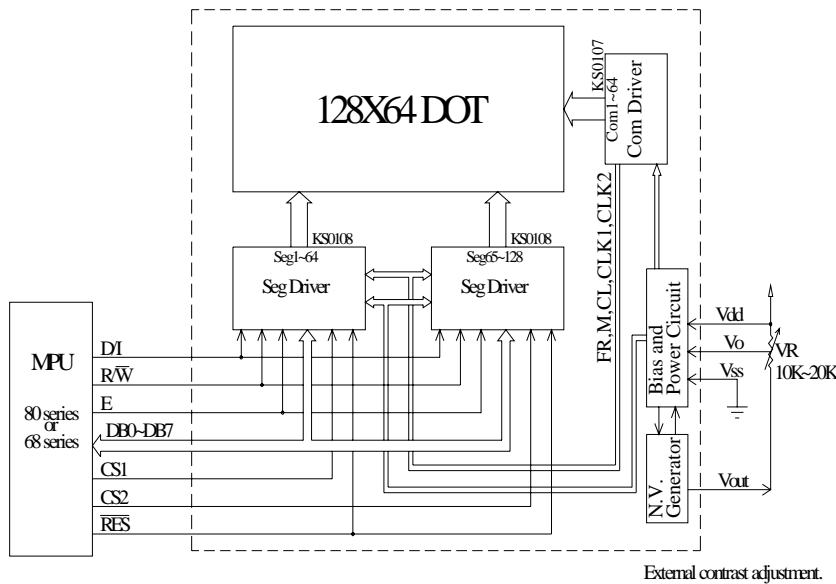

External contrast adjustment.

### LEDBL Drive Method

1. Drive from A/K

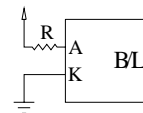

2. Drive from pin19, pin20

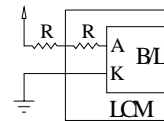

## 9. Timing Characteristics

| Characteristic         | Symbol | Min  | Typ | Max | Unit |
|------------------------|--------|------|-----|-----|------|
| E cycle                | tcyc   | 1000 | -   | -   | ns   |
| E high level width     | twhE   | 450  | -   | -   | ns   |
| E low level width      | twlE   | 450  | -   | -   | ns   |
| E rise time            | tr     | -    | -   | 25  | ns   |
| E fall time            | tf     | -    | -   | 25  | ns   |
| Address set-up time    | tas    | 140  | -   | -   | ns   |
| Address hold time      | tah    | 10   | -   | -   | ns   |
| Data set-up time       | tdsw   | 200  | -   | -   | ns   |
| Data delay time        | tddr   | -    | -   | 320 | ns   |
| Data hold time (write) | tdhw   | 10   | -   | -   | ns   |
| Data hold time (read)  | tdhr   | 20   | -   | -   | ns   |

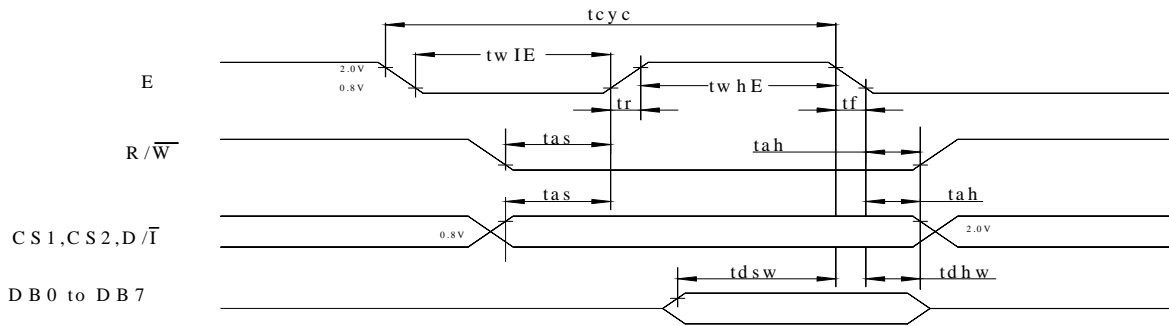

MPU Write Timing

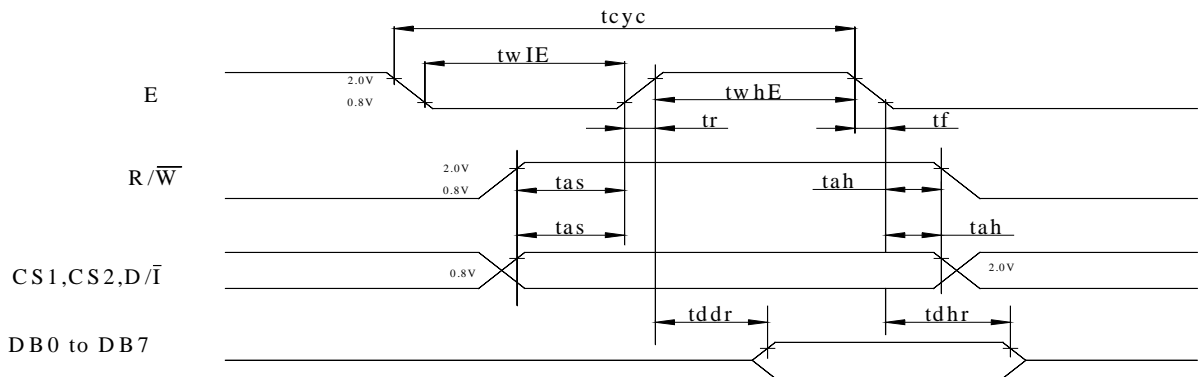

MPU Read Timing

# 10. Display Control Instruction

The display control instructions control the internal state of the KS0108B. Instruction is received from MPU to KS0108B for the display control. The following table shows various instructions

| Instruction          | D/I | R/W | DB7              | DB6 | DB5                      | DB4                   | DB3 | DB2         | DB1 | DB0 | Function  |  |
|----------------------|-----|-----|------------------|-----|--------------------------|-----------------------|-----|-------------|-----|-----|---|--|
| Display ON/OFF       | 0   | 0   | 0                | 0   | 1                        | 1                     | 1   | 1           | 1   | 0/1 | Controls the display on or off. Internal status and display RAM data are not affected.<br>0:OFF, 1:ON               |  |
| Set Address          | 0   | 0   | 0                | 1   | Y address (0~63)         |                       |     |             |     |     | Sets the Y address in the Y address counter.  |  |
| Set Page (X address) | 0   | 0   | 1                | 0   | 1                        | 1                     | 1   | Page (0 ~7) |     |     | Sets the X address at the X address register.   |  |
| Display Start Line   | 0   | 0   | 1                | 1   | Display start line(0~63) |                       |     |             |     |     | Indicates the display data RAM displayed at the top of the screen.  |  |
| Status Read          | 0   | 1   | B<br>U<br>S<br>Y | 0   | O<br>N/<br>O<br>F<br>F   | R<br>E<br>S<br>E<br>T | 0   | 0           | 0   | 0   | Read status.<br>BUSY 0:Ready<br>1:In operation<br>ON/OFF 0:Display ON<br>1:Display OFF<br>RESET 0:Normal<br>1:Reset |  |
| Write Display Data   | 1   | 0   | Display Data     |     |                          |                       |     |             |     |     |   | Writes data (DB0:7) into display data RAM. After writing instruction, Y address is increased by 1 automatically. |
| Read Display Data    | 1   | 1   | Display Data     |     |                          |                       |     |             |     |     |   | Reads data (DB0:7) from display data RAM to the data bus.  |

# 11. Detailed Explanation

## Display On/Off

| R/W | D/I | DB7 | DB6 | DB5 | DB4 | DB3 | DB2 | DB1 | DB0 |
|-----|-----|-----|-----|-----|-----|-----|-----|-----|-----|
| 0   | 0   | 0   | 0   | 1   | 1   | 1   | 1   | 1   | D   |

The display data appears when D is 1 and disappears when D is 0. Though the data is not on the screen with D = 0, it remains in the display data RAM. Therefore, you can make it appear by changing D = 0 into D = 1.

## Display Start Line

| R/W | D/I | DB7 | DB6 | DB5 | DB4 | DB3 | DB2 | DB1 | DB0 |
|-----|-----|-----|-----|-----|-----|-----|-----|-----|-----|
| 0   | 0   | 1   | 1   | A   | A   | A   | A   | A   | A   |

Z address AAAAAA ( binary ) of the display data RAM is set in the display start line register and displayed at the top of the screen. Figure 2. shows examples of display ( 1/64 duty cycle ) when the start line = 0-3. When the display duty cycle is 1/64 or more ( ex. 1/32, 1/24 etc. ), the data of total line number of LCD screen, from the line specified by display start line instruction, is displayed

## Set Page ( X Address )

| R/W | D/I | DB7 | DB6 | DB5 | DB4 | DB3 | DB2 | DB1 | DB0 |
|-----|-----|-----|-----|-----|-----|-----|-----|-----|-----|
| 0   | 0   | 1   | 0   | 1   | 1   | 1   | A   | A   | A   |

X address AAA ( binary ) of the display data RAM is set in the X address register. After that, writing or reading to or from MPU is executed in this specified page until the next page is set. See Figure 1.



Writes 8-bit data DDDDDDDD ( binary ) into the display data RAM. The Y address is increased by 1 automatically.

**Read Display Data**

| R/W | D/I | DB7 | DB6 | DB5 | DB4 | DB3 | DB2 | DB1 | DB0 |
|-----|-----|-----|-----|-----|-----|-----|-----|-----|-----|
| 0   | 0   | D   | D   | D   | D   | 1   | D   | D   | D   |

Reads out 8-bit data DDDDDDDD ( binary ) from the display data RAM. Then Y address is increased by 1 automatically.

One dummy read is necessary right after the address setting. For details, refer to the

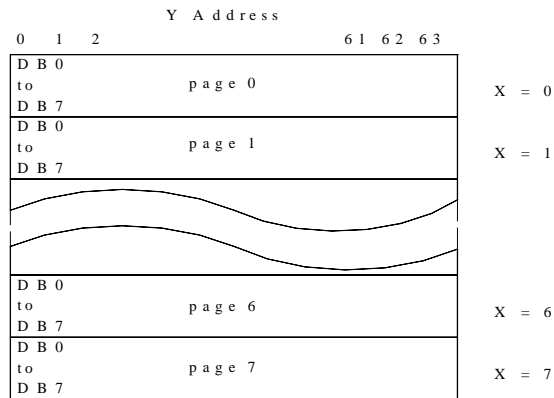
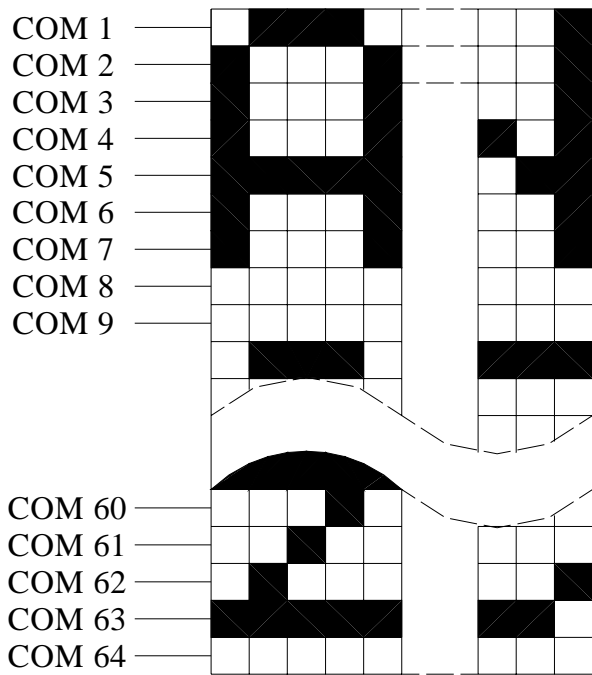
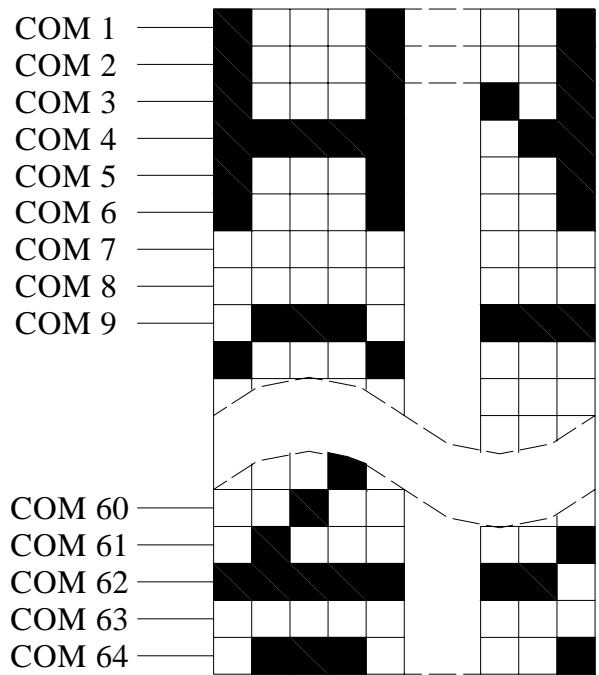

Figure 1.

explanation of output register in “Function of Each Block”.



Start line = 0



Start line = 1

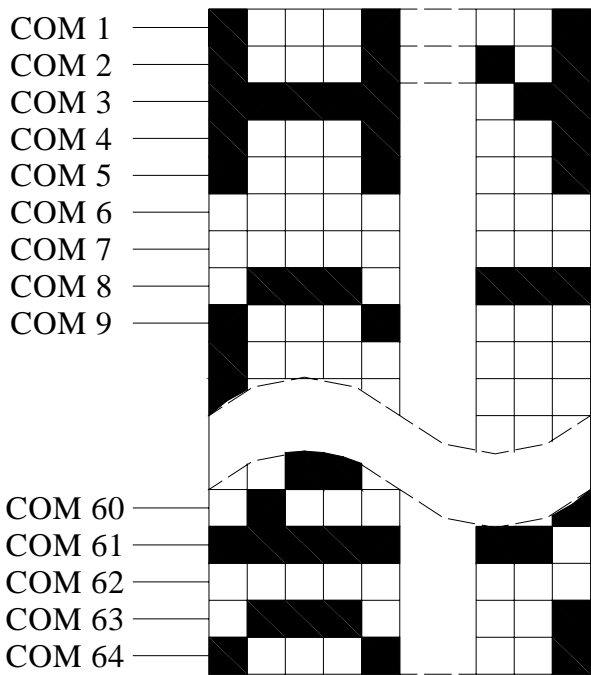

Start line = 3

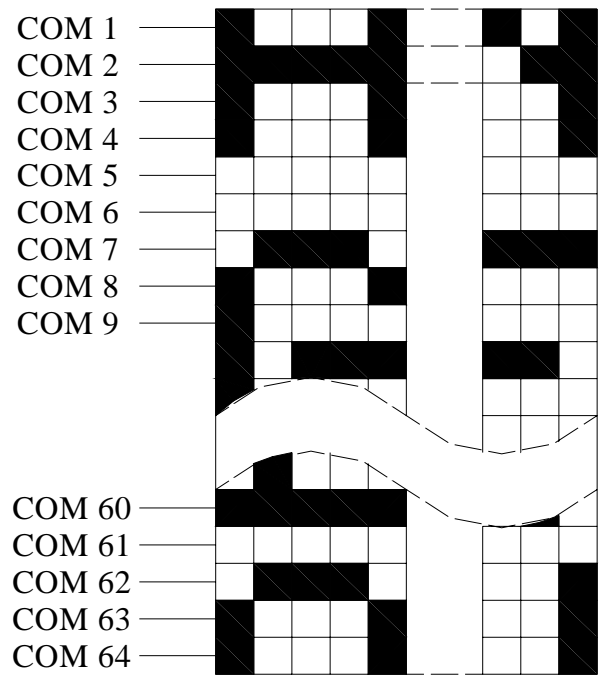

Start line = 4

Figure 2.

# 12. Quality Assurance

## Screen Cosmetic Criteria

| No.                | Defect                               | Judgment Criterion   | Partition         |                                      |              |           |                    |   |                    |   |           |   |                   |                                      |              |           |                    |   |                    |   |           |   |       |
|--------------------|--------------------------------------|--|-------------------|--------------------------------------|--------------|-----------|--------------------|---|--------------------|---|-----------|---|-------------------|--------------------------------------|--------------|-----------|--------------------|---|--------------------|---|-----------|---|-------|
| 1                  | Spots                                | <p>A)Clear</p> <table border="0"> <tr> <td><u>Size: d mm</u></td> <td><u>Acceptable Qty in active area</u></td> </tr> <tr> <td><math>d \leq 0.1</math></td> <td>Disregard</td> </tr> <tr> <td><math>0.1 &lt; d \leq 0.2</math></td> <td>6</td> </tr> <tr> <td><math>0.2 &lt; d \leq 0.3</math></td> <td>2</td> </tr> <tr> <td><math>0.3 &lt; d</math></td> <td>0</td> </tr> </table> <p>Note: Including pin holes and defective dots which must be within one pixel size.</p> <p>B)Unclear</p> <table border="0"> <tr> <td><u>Size: d mm</u></td> <td><u>Acceptable Qty in active area</u></td> </tr> <tr> <td><math>d \leq 0.2</math></td> <td>Disregard</td> </tr> <tr> <td><math>0.2 &lt; d \leq 0.5</math></td> <td>6</td> </tr> <tr> <td><math>0.5 &lt; d \leq 0.7</math></td> <td>2</td> </tr> <tr> <td><math>0.7 &lt; d</math></td> <td>0</td> </tr> </table> | <u>Size: d mm</u> | <u>Acceptable Qty in active area</u> | $d \leq 0.1$ | Disregard | $0.1 < d \leq 0.2$ | 6 | $0.2 < d \leq 0.3$ | 2 | $0.3 < d$ | 0 | <u>Size: d mm</u> | <u>Acceptable Qty in active area</u> | $d \leq 0.2$ | Disregard | $0.2 < d \leq 0.5$ | 6 | $0.5 < d \leq 0.7$ | 2 | $0.7 < d$ | 0 | Minor |
| <u>Size: d mm</u>  | <u>Acceptable Qty in active area</u> |  |                   |                                      |              |           |                    |   |                    |   |           |   |                   |                                      |              |           |                    |   |                    |   |           |   |       |
| $d \leq 0.1$       | Disregard                            |  |                   |                                      |              |           |                    |   |                    |   |           |   |                   |                                      |              |           |                    |   |                    |   |           |   |       |
| $0.1 < d \leq 0.2$ | 6                                    |  |                   |                                      |              |           |                    |   |                    |   |           |   |                   |                                      |              |           |                    |   |                    |   |           |   |       |
| $0.2 < d \leq 0.3$ | 2                                    |  |                   |                                      |              |           |                    |   |                    |   |           |   |                   |                                      |              |           |                    |   |                    |   |           |   |       |
| $0.3 < d$          | 0                                    |  |                   |                                      |              |           |                    |   |                    |   |           |   |                   |                                      |              |           |                    |   |                    |   |           |   |       |
| <u>Size: d mm</u>  | <u>Acceptable Qty in active area</u> |  |                   |                                      |              |           |                    |   |                    |   |           |   |                   |                                      |              |           |                    |   |                    |   |           |   |       |
| $d \leq 0.2$       | Disregard                            |  |                   |                                      |              |           |                    |   |                    |   |           |   |                   |                                      |              |           |                    |   |                    |   |           |   |       |
| $0.2 < d \leq 0.5$ | 6                                    |  |                   |                                      |              |           |                    |   |                    |   |           |   |                   |                                      |              |           |                    |   |                    |   |           |   |       |
| $0.5 < d \leq 0.7$ | 2                                    |  |                   |                                      |              |           |                    |   |                    |   |           |   |                   |                                      |              |           |                    |   |                    |   |           |   |       |
| $0.7 < d$          | 0                                    |  |                   |                                      |              |           |                    |   |                    |   |           |   |                   |                                      |              |           |                    |   |                    |   |           |   |       |
| 2                  | Bubbles in Polarize                  | <table border="0"> <tr> <td><u>Size: d mm</u></td> <td><u>Acceptable Qty in active area</u></td> </tr> <tr> <td><math>d \leq 0.3</math></td> <td>Disregard</td> </tr> <tr> <td><math>0.3 &lt; d \leq 1.0</math></td> <td>3</td> </tr> <tr> <td><math>1.0 &lt; d \leq 1.5</math></td> <td>1</td> </tr> <tr> <td><math>1.5 &lt; d</math></td> <td>0</td> </tr> </table>  | <u>Size: d mm</u> | <u>Acceptable Qty in active area</u> | $d \leq 0.3$ | Disregard | $0.3 < d \leq 1.0$ | 3 | $1.0 < d \leq 1.5$ | 1 | $1.5 < d$ | 0 | Minor             |                                      |              |           |                    |   |                    |   |           |   |       |
| <u>Size: d mm</u>  | <u>Acceptable Qty in active area</u> |  |                   |                                      |              |           |                    |   |                    |   |           |   |                   |                                      |              |           |                    |   |                    |   |           |   |       |
| $d \leq 0.3$       | Disregard                            |  |                   |                                      |              |           |                    |   |                    |   |           |   |                   |                                      |              |           |                    |   |                    |   |           |   |       |
| $0.3 < d \leq 1.0$ | 3                                    |  |                   |                                      |              |           |                    |   |                    |   |           |   |                   |                                      |              |           |                    |   |                    |   |           |   |       |
| $1.0 < d \leq 1.5$ | 1                                    |  |                   |                                      |              |           |                    |   |                    |   |           |   |                   |                                      |              |           |                    |   |                    |   |           |   |       |
| $1.5 < d$          | 0                                    |  |                   |                                      |              |           |                    |   |                    |   |           |   |                   |                                      |              |           |                    |   |                    |   |           |   |       |
| 3                  | Scratch                              | In accordance with spots cosmetic criteria. When the light reflects on the panel surface, the scratches are not to be remarkable.  | Minor             |                                      |              |           |                    |   |                    |   |           |   |                   |                                      |              |           |                    |   |                    |   |           |   |       |
| 4                  | Allowable Density                    | Above defects should be separated more than 30mm each other.   | Minor             |                                      |              |           |                    |   |                    |   |           |   |                   |                                      |              |           |                    |   |                    |   |           |   |       |
| 5                  | Coloration                           | Not to be noticeable coloration in the viewing area of the LCD panels.<br>Back-light type should be judged with back-light on state only.  | Minor             |                                      |              |           |                    |   |                    |   |           |   |                   |                                      |              |           |                    |   |                    |   |           |   |       |



# 13. Reliability

## Content of Reliability Test

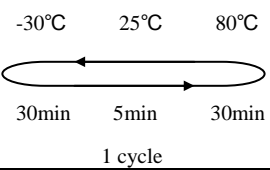
| Environmental Test                   |  |  |                     |
|--------------------------------------|--|--|---------------------|
| Test Item                            | Content of Test  | Test Condition   | Applicable Standard |
| High Temperature storage             | Endurance test applying the high storage temperature for a long time.  | 80°C<br>200hrs   | ---                 |
| Low Temperature storage              | Endurance test applying the high storage temperature for a long time.  | -30°C<br>200hrs  | ---                 |
| High Temperature Operation           | Endurance test applying the electric stress (Voltage & Current) and the thermal stress to the element for a long time.                             | 70°C<br>200hrs   | ---                 |
| Low Temperature Operation            | Endurance test applying the electric stress under low temperature for a long time.   | -20°C<br>200hrs  | ---                 |
| High Temperature/ Humidity Storage   | Endurance test applying the high temperature and high humidity storage for a long time.  | 80°C,90%RH<br>96hrs  | ---                 |
| High Temperature/ Humidity Operation | Endurance test applying the electric stress (Voltage & Current) and temperature / humidity stress to the element for a long time.                  | 70°C,90%RH<br>96hrs  | ---                 |
| Temperature Cycle                    | Endurance test applying the low and high temperature cycle.<br> | -30°C/80°C<br>10 cycles                                    | ---                 |
| Mechanical Test                      |  |  |                     |
| Vibration test                       | Endurance test applying the vibration during transportation and using.   | 10~22Hz→ 1.5mmp-p<br>22~500Hz→ 1.5G<br>Total 0.5hrs        | ---                 |
| Shock test                           | Constructional and mechanical endurance test applying the shock during transportation.   | 50G Half sign<br>wave 11 msdc<br>3 times of each direction | ---                 |
| Atmospheric pressure test            | Endurance test applying the atmospheric pressure during transportation by air.   | 115mbar<br>40hrs   | ---                 |
| Others                               |  |  |                     |
| Static electricity test              | Endurance test applying the electric stress to the terminal.   | VS=800V,RS=1.5kΩ<br>CS=100pF<br>1 time                     | ---                 |

\*\*\*Supply voltage for logic system=5V. Supply voltage for LCD system =Operating voltage at 25°C

## 14. Backlight Information

### Specification

| PARAMETER          | SYMBOL           | MIN | TYP   | MAX | UNIT              | TEST CONDITION          |
|--------------------|------------------|-----|-------|-----|-------------------|-------------------------|
| Supply Current     | I <sub>LED</sub> | —   | 330   | 660 | mA                | V=4.2V                  |
| Supply Voltage     | V                | -   | 4.2   | 4.6 | V                 | -                       |
| Reverse Voltage    | V <sub>R</sub>   | -   | -     | 10  | V                 | -                       |
| Luminous Intensity | I <sub>V</sub>   | -   | 186.6 | -   | cd/m <sup>2</sup> | I <sub>LED</sub> =330mA |
| Wave Length        | λ <sub>p</sub>   | —   | 570   | —   | nm                | I <sub>LED</sub> =330mA |
| Life Time          | -                | -   | 100K  | -   | Hr.               | V ≤ 4.6V                |
| Color              | Yellow Green     |     |       |     |                   |                         |