

**WG12864M** Graphic 128x64dots

**Dimension drawing**

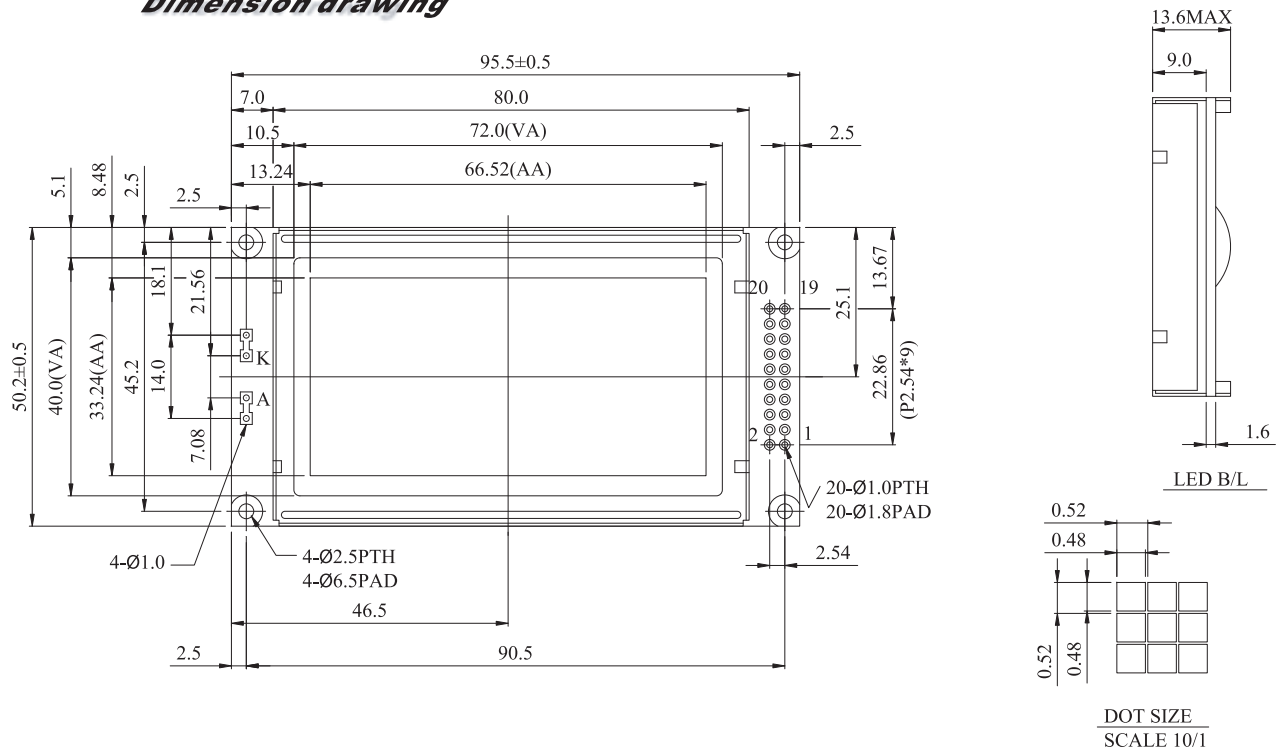

**Feature**

1. Built-in controller Samsung-(KS0107 · KS0108 or Equivalent)
2. +5V power supply
3. 1/64 duty cycle
4. N.V. Built-in

Pin NO.	Symbol	Function
1	Vss	GND
2	Vdd	Power supply
3	Vo	Contrast Adjustment
4	D/I	Data/instruction
5	R/W	Data read/write
6	E	H→L Enable signal
7	DB0	Data bus line
8	DB1	Data bus line
9	DB2	Data bus line
10	DB3	Data bus line
11	DB4	Data bus line
12	DB5	Data bus line
13	DB6	Data bus line
14	DB7	Data bus line
15	CS1	Chip select for IC1
16	CS2	Chip select for IC2
17	RST	Reset
18	Vee	Negative voltage output
19	A	Power supply for LED+(4.2V)RA=0Ω
20	K	Power supply for LED (0V)

**Mechanical Data**

Item	Standard Value	Unit
Module Dimension	<b>95.5x50.2</b>	mm
Viewing Area	<b>72.0x40</b>	mm
Mounting hole	<b>90.5x45.2</b>	mm
Dot Pitch	<b>0.52x0.52</b>	mm

**Absolute Maximum Rating**

Item	Symbol	Standard Value			Unit
		min.	typ.	max.	
Power Supply	VDD-VSS	4.75	5.0	5.25	V
Input Voltage	VI	-0.3	---	VDD	V

Note : VSS=0 Volt, VDD=5.0 Volt.

**Electronical Characteristics**

Item	Symbol	Condition	Standard Value			Unit
			min.	typ.	max.	
Input Voltage	VDD	L level	0.7VDD	---	VDD	V
	VIO	H level	0	---	0.3VDD	V
Supply Current	IDD	VDD=5V	---	2.5	7.5	m
Recommended LC Driving Voltage for Normal Temp. Version module	VDD-V0	-20°C	9.9	10.4	10.9	V
		0°C	9.7	10.2	10.7	
		25°C	8.9	9.4	9.9	
		50°C	8.6	9.1	9.6	
		70°C	8.4	8.9	9.4	
LED Forward Voltage	VF	25°C	---	4.2	4.6	V
LED Forward Current	IF	25°C Array	---	330	660	mA
		Edge	---	120	240	
EL Power Supply Current	IEL	Vel=110VAC;400Hz	---	---	5.0	m

Graphic type