



FEATURES:

- Step Down DC/DC LED driver
- Constant current output
- Ultra Wide (8:1) input voltage range
- High efficiency up to 97%
- Operating Temperature range -40°C to +85°C
- Open and Short LED Protection
- PWM/Digital and Analog Voltage dimming
- Built with MLCC Capacitors only

Models
Single output



Model	Input Voltage (V)	Output Voltage (V)	Output Current (mA)	Efficiency (%)	Ripple & Noise (mV p-p)
AMLD-6015Z	7-60	2-57	150	97	150
AMLD-6025Z	7-60	2-57	250	97	200
AMLD-6030Z	7-60	2-57	300	97	250
AMLD-6035Z	7-60	2-57	350	97	300
AMLD-6050Z	7-60	2-57	500	97	400
AMLD-6070Z	7-60	2-57	700	97	500
AMLD-60100Z	7-60	2-48	1000	97	800

NOTE: All specifications in this datasheet are measured at an ambient temperature of 25°C, humidity<75%, nominal input voltage and at rated output load unless otherwise specified.

Input Specifications

Parameters	Nominal	Typical	Maximum	Units
Voltage range		7-60		VDC
Filter	Capacitor			
Absolute Maximum Rating			65	VDC
Peak Input Voltage time			500	ms
DC/DC ON (Leave open if not used)	ON –Open or 0.3V<Vadj<1.25			
DC/DC OFF	OFF(shutdown) – Vadj<0.15			
Maximum Remote pin drive current	Vadj = 1.25V		1	mA
Quiescent Current in Shutdown mode	Vin = 60V, Vadj <0.15		0.1	mA
On/Off Control (Digital Control)	Max PWM Frequency 1KHz			
Output current adjustment	PWM Frequency <300Hz	0.1 to 100		%
Minimum Switch ON/OFF time		200		ns
On/Off Control (Analog Dimming Control) (Leave open if not used)	Input voltage range	0.3-1.25		VDC
Output current adjustment*	Vin-Vout<30	25-100		%
Control Voltage Range limits	ON – 0.2 – 0.3V (Vadj rise)			
	OFF – 0.15-0.25V (Vadj fall)			
Maximum Analog pin drive current	Vadj = 1.25V		1	mA

NOTE: Vin –Vout must be less than 30V to maintain current adjustment range

Output Specifications

Parameters	Conditions	Typical	Maximum	Units
Current accuracy		±7		%
Output Voltage range	V input = 60V	2-57		VDC
Output current	Vin – Vout > 3V			
Short Circuit protection	Regulated at the rated current for each model			
Output no load Protection	Continuously			
Max load capacitance			47	µF
Temperature coefficient	Ta = -40 to +85°C	±0.03		%/°C
Ripple & Noise	20MHz Bandwidth	See model table		

General Specifications

Parameters	Conditions	Typical	Maximum	Units
Switching frequency	100% load	20 - 500		KHz
Operating temperature		-40 to +85		°C
Storage temperature		-40 to +150		°C
Derating		See derating curve		
Maximum case temperature			110	°C
Thermal Impedance	Free air convection	+30		°C/W
Cooling		Free air convection		
Humidity			95	% RH
Case material		Non-Conductive Black Plastic (UL94-V0 rated)		
Weight		12.5		g
Dimensions (L x W x H)	1.25 x 0.80 x 0.49 inches	31.75 x 20.32 x 12.45 mm		
MTBF		> 950 000hrs (MIL-HDBK-217 F at +25 °C)		
Maximum Soldering Temperature	1.5mm from case for 10sec.		260	°C

NOTES:

1. Reversed polarity at the input power will damage the driver. The input ground must not be connected to the negative output.
2. Leave the pin VADJ opened if not used, grounding VADJ will shut the driver off, connecting VADJ to +Vin will damage the driver.
3. Maximum output open voltage is equal to input voltage.

Safety Specifications

Parameters	
Standards	Designed to meet EN 55015 (CISPR22)

Pin Out Specifications

Pin	Single	
2	- V Input	- DC Supply
3	- V Input	- DC Supply
4	Vadj	PWM/ON/OFF or not used
9	- V Output	LED Cathode connection
11	- V Output	LED Cathode connection
14	+ V Output	LED Anode connection
16	+ V Output	LED Anode connection
22	+ V Input	+ DC Supply
23	+ V Input	+ DC Supply

Derating

Free Air Convection

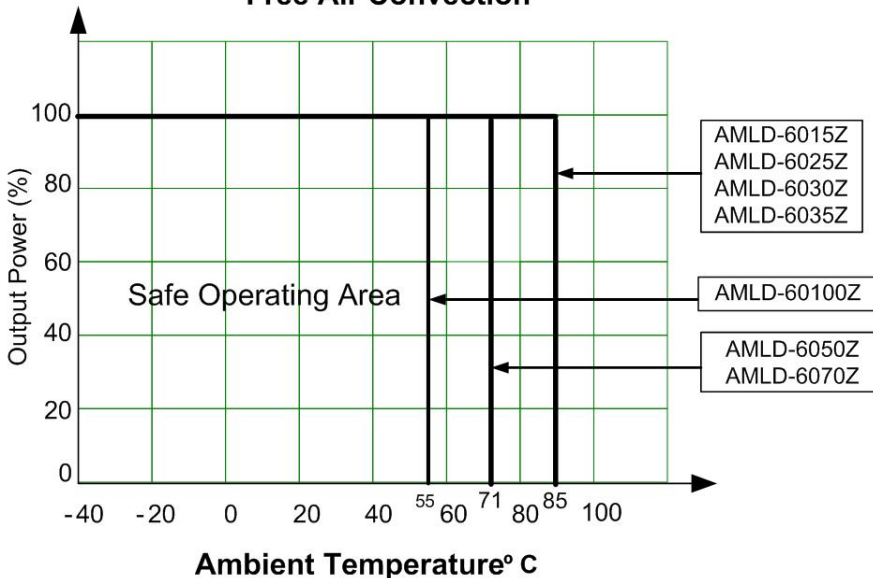

Dimensions

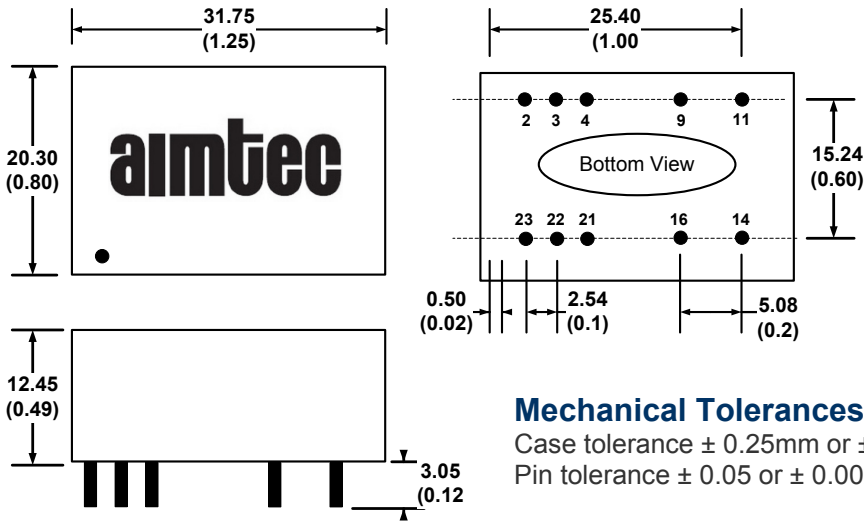

Application circuit examples:

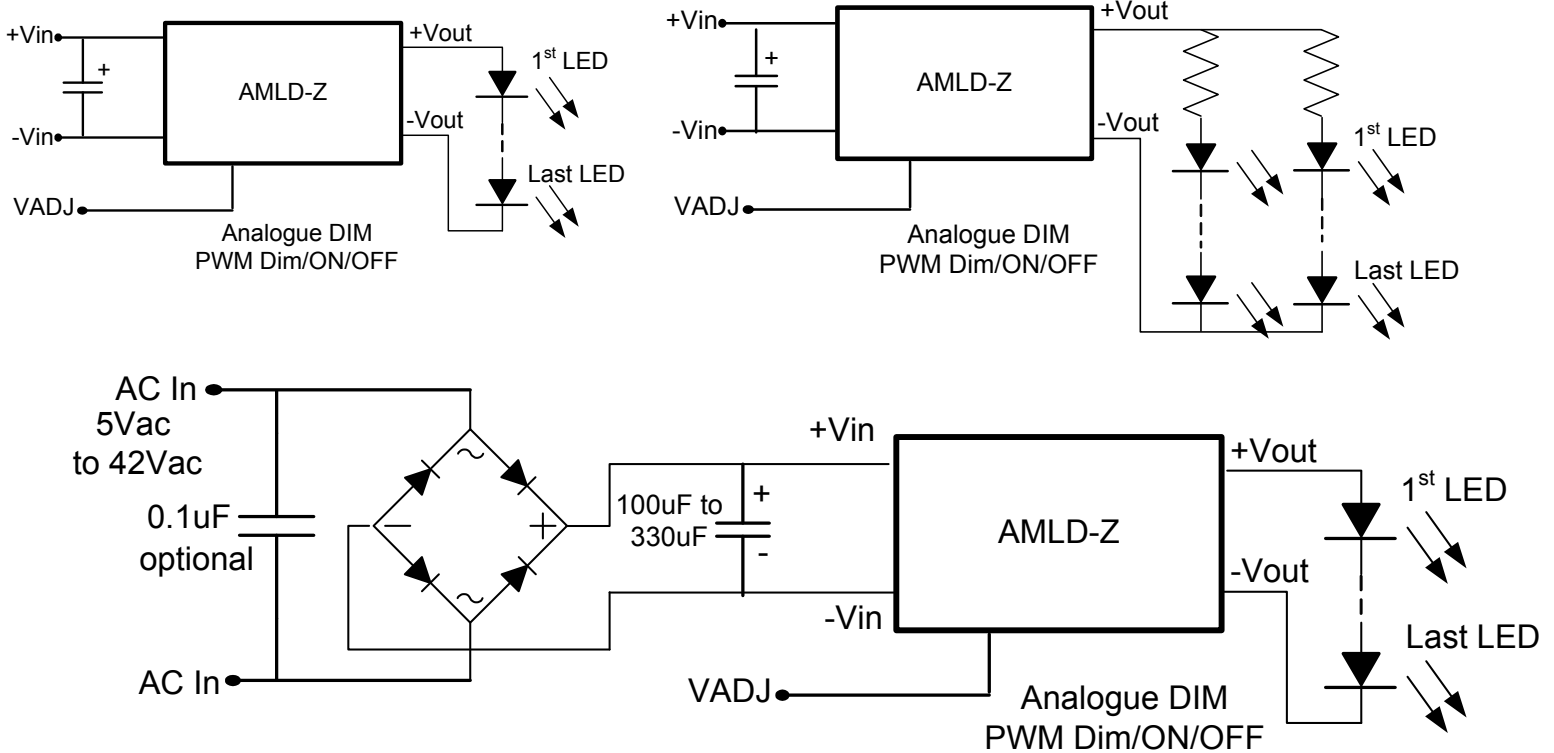

Output Current Adjustment by External DC Control Voltage (VCTRL):

VCTRL = VADJ (If VCTRL = 0-1.25Vdc)

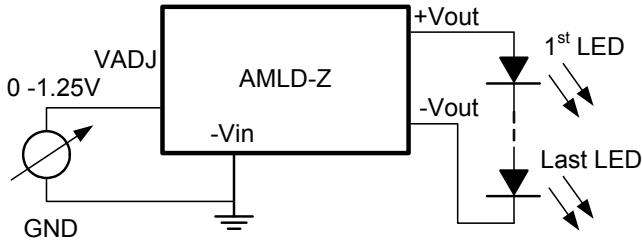

$$VADJ = \left[\frac{R2}{R1 + R2} \right] \times VCTRL \quad (\text{If } VCTRL > 1.25Vdc)$$

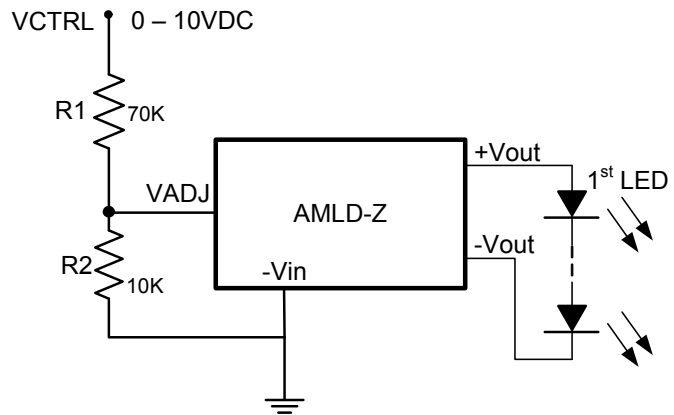
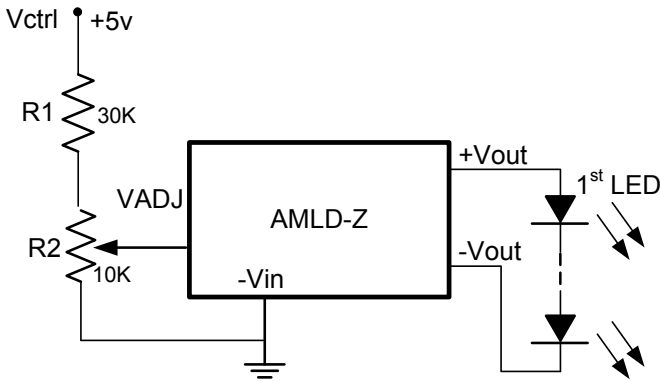

$$VADJ = \left[\frac{R3}{R2 + R3} \right] \times 2.5$$

If VCTRL = Vin

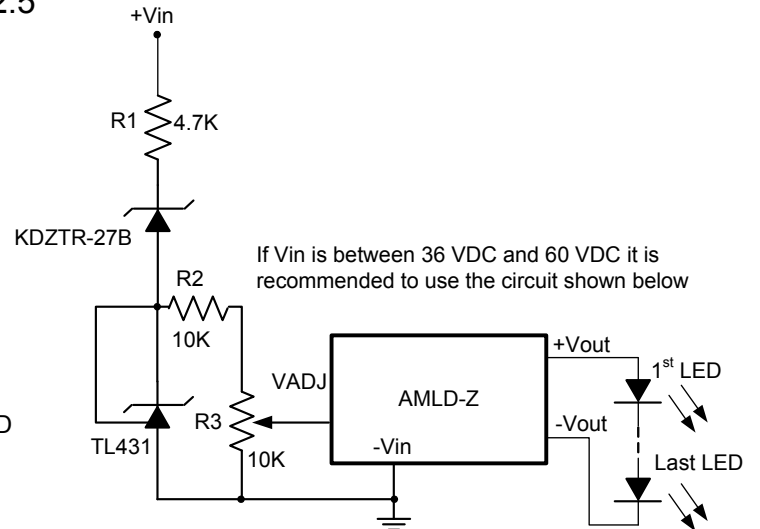
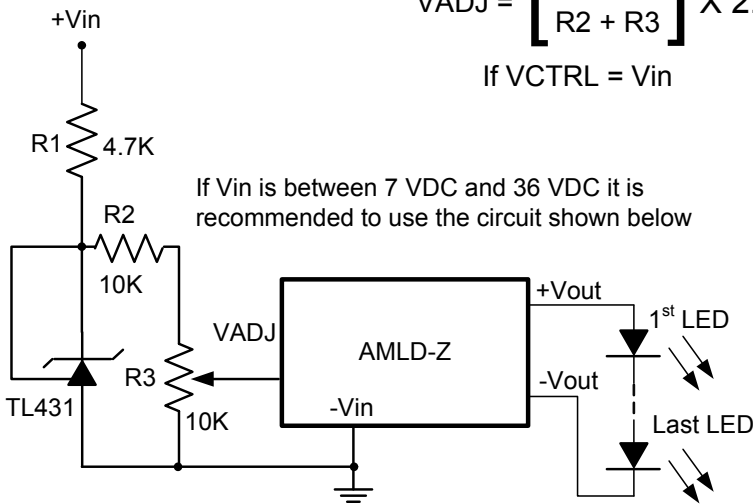

Resistive Dimming Control

A simplified dimming control can be achieved using a variable resistor connected between VADJ and GND. Capacitor CADJ is optional, it is installed to limit AC mains interference and high frequency noise. The recommended value of CADJ is 0.22μF.

NOTE: Typical error is ±10% with resistive dimming control

The output current is given by:

$$I_{outnom} \approx \frac{I_{out} \times R_{adj}}{R_{adj} + 50K}$$

If RADJ is between 0 and 2M ohm, the maximum adjustment range of Iout is 25% to 90% (for Vin – Vout < 20V)

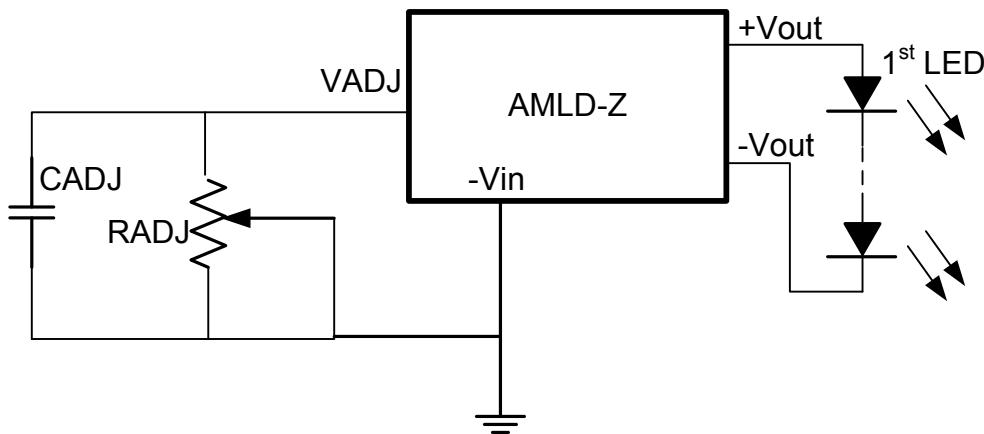

Output Current Adjustment by PWM Control: Driving VADJ Directly

A Pulse Width Modulation (PWM) signal with a duty cycle DPWM can be applied to the ADJ pin as shown below.

The output current is given by:

$$I_{out} \approx I_{outnom} \times DPWM \quad \left[\begin{array}{l} \text{if PWM frequency} < 300\text{Hz,} \\ \text{for } 0.1 < DPWM < 1 \end{array} \right]$$

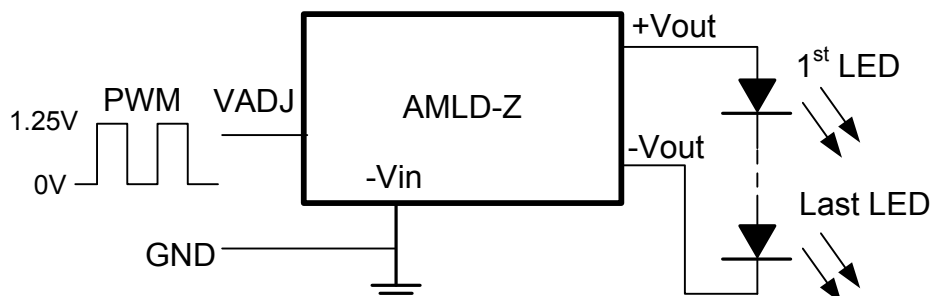

Driving VADJ Via Open Collector Transistor

The VADJ can also be driven via an open collector transistor as shown below. The diode and resistor serve to suppress any possible high amplitude negative voltage spikes to the VADJ input resulting from the collector to emitter capacitance of the transistor. Any negative voltage spikes will cause errors in output current and/or unstable driver operation.

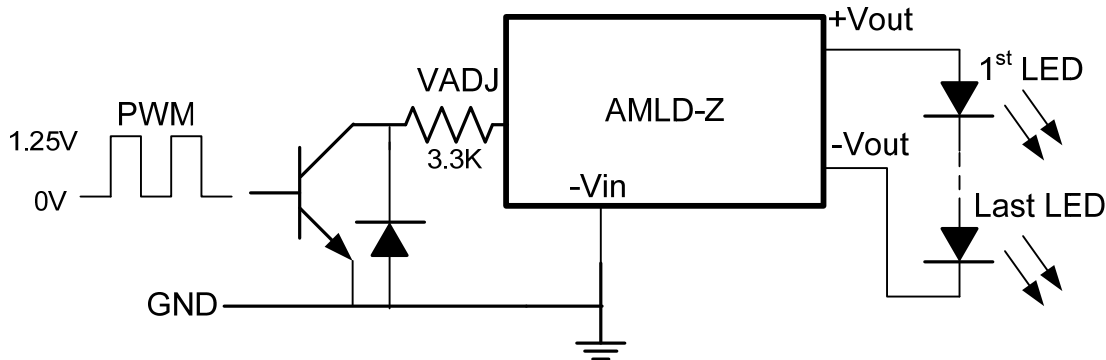

Driving the VADJ from a Microcontroller

The VADJ can be driven from an open drain output of a microcontroller as shown below. The diode and resistor serve to suppress any possible high amplitude negative voltage spikes to the VADJ input resulting from the drain to source capacitance of the FET. Any negative voltage spikes will cause errors in output current and/or unstable driver operation.

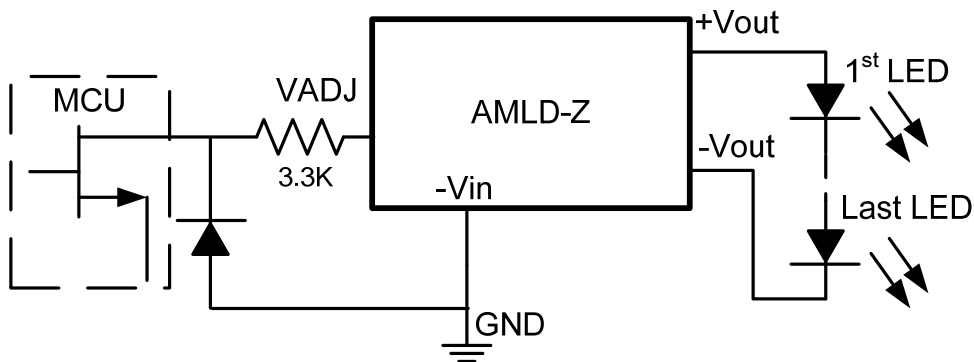

Output Current Adjustment by PWM Control (Dimming):

A PWM signal must have a frequency of greater than 100Hz to prevent any visible flicker.

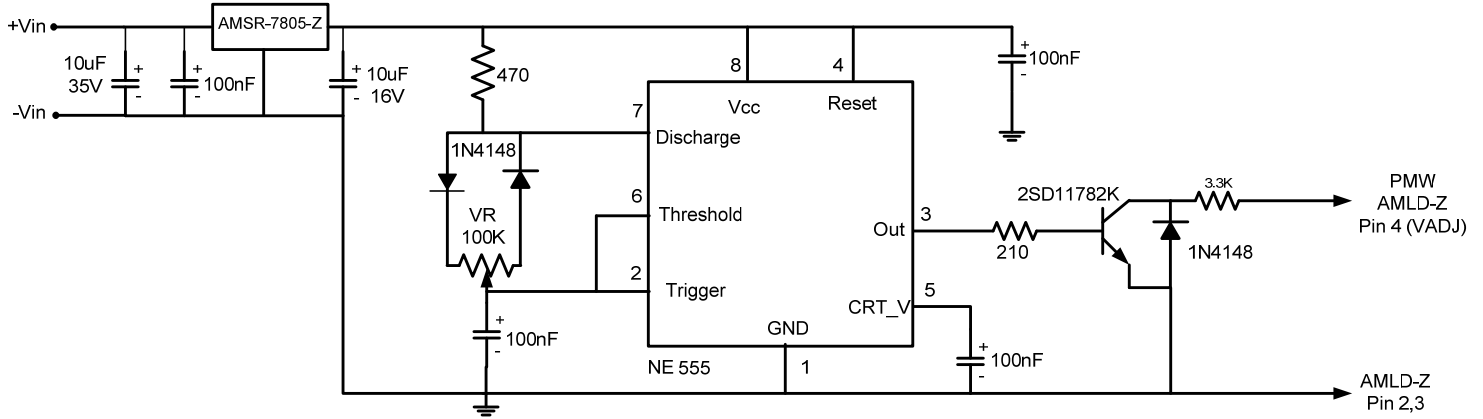

Output Current Adjustment by PWM Control (Flash):

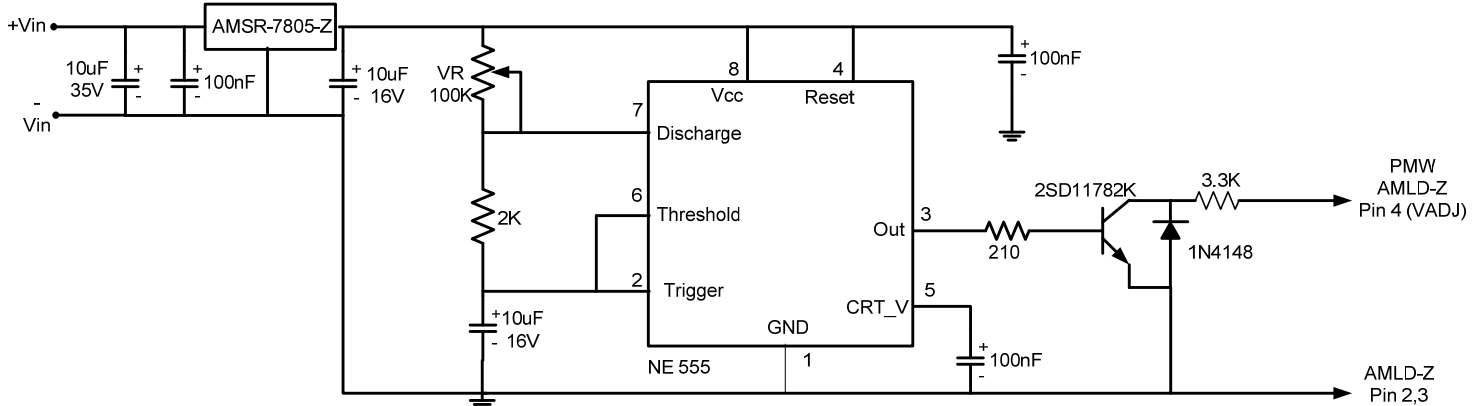

Recommended Class B EMI Filter:

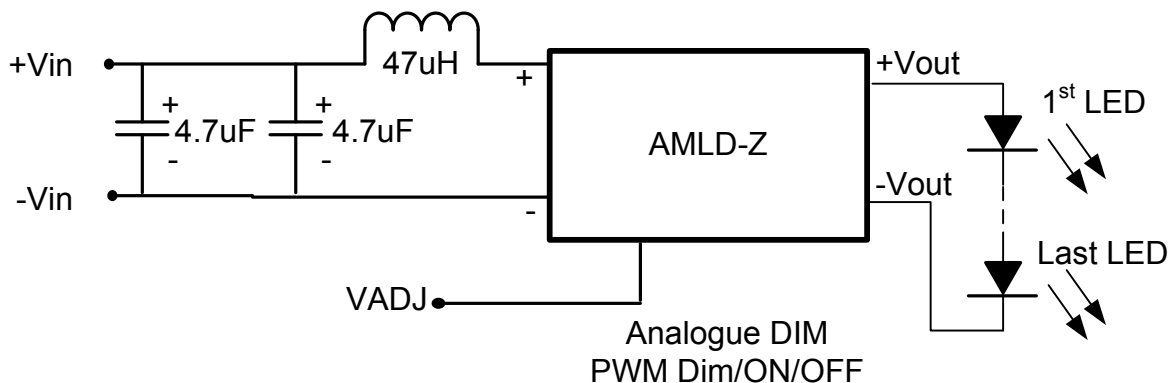

Typical Characteristics:

AMLD-6030Z

Operating Frequency vs Input Voltage
(Forward Voltage = 3.5V per LED)

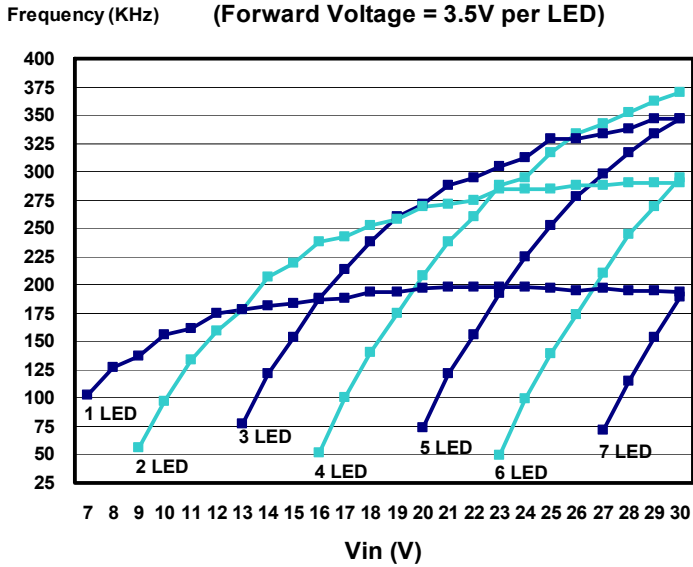

Efficiency vs Vin
(Forward Voltage = 3.5V per LED)

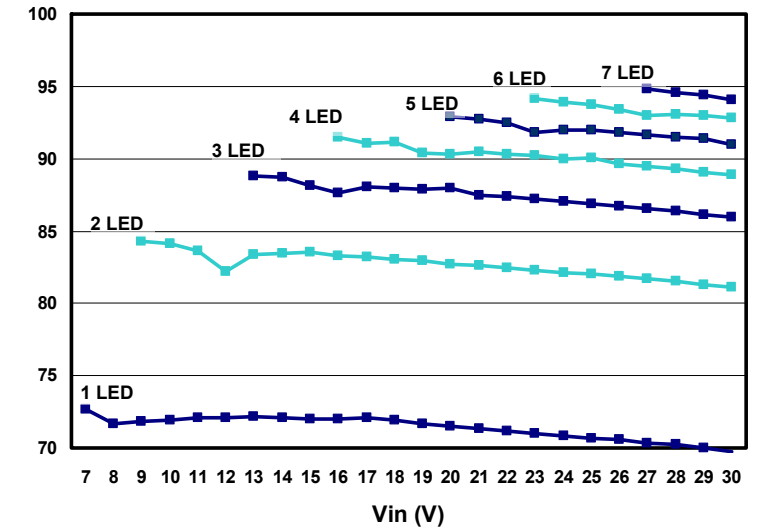

Output Current Vs V_{ADJ}

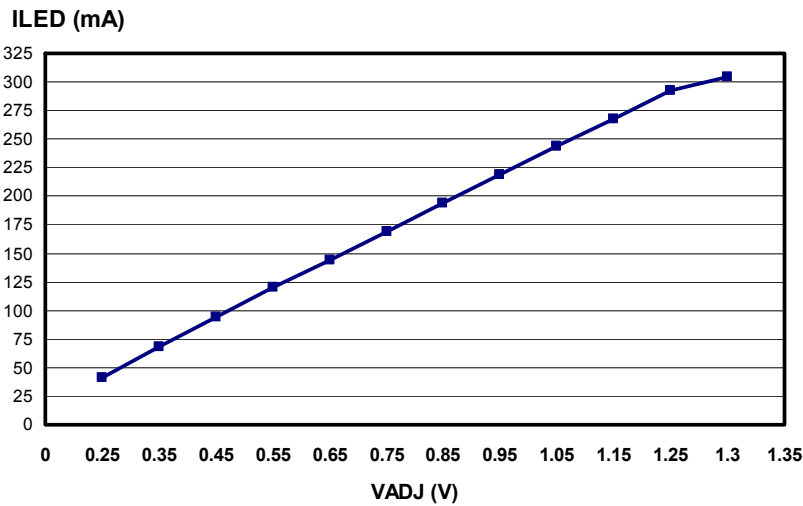

Typical Characteristics: AMLD-6035Z

Operating Frequency vs Input Voltage
(Forward Voltage = 3.5V per LED)

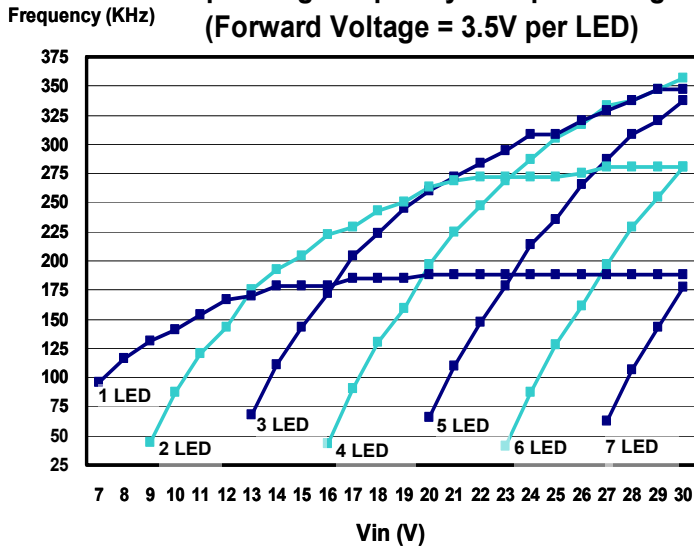

Efficiency vs Vin
(Forward Voltage = 3.5V per LED)

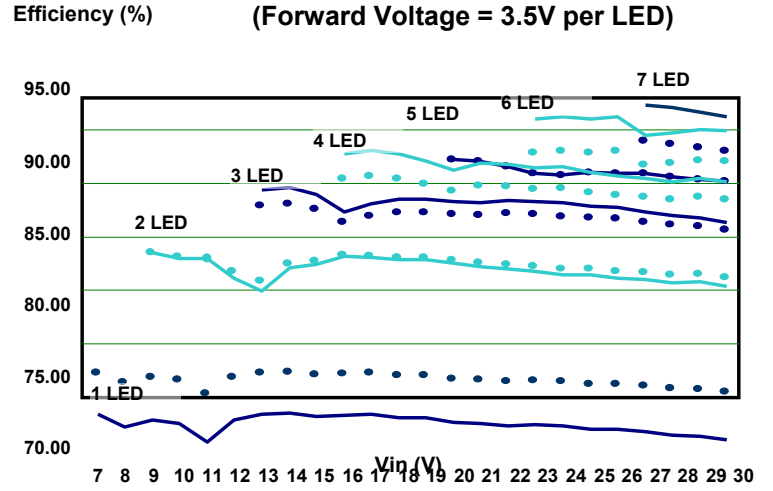

Output Current Vs VADJ

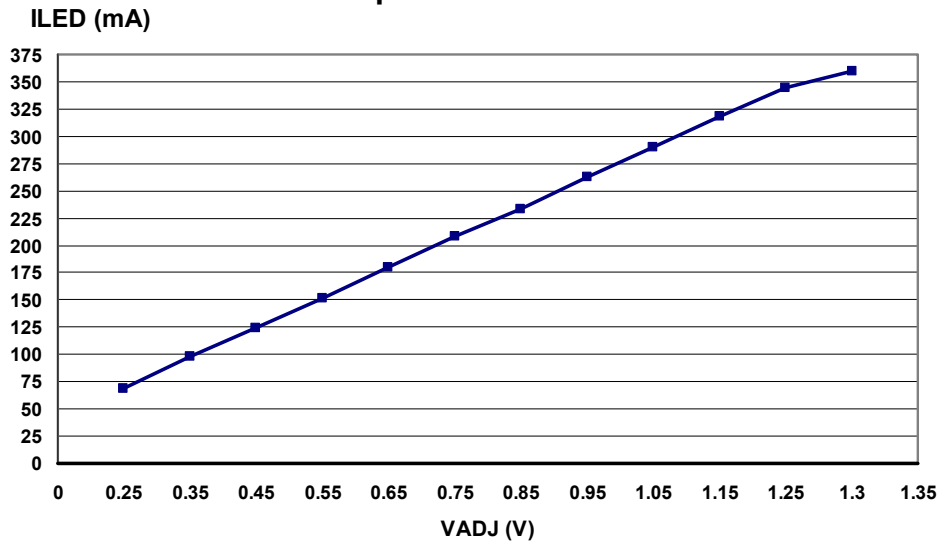

Typical Characteristics: AMLD-6050Z

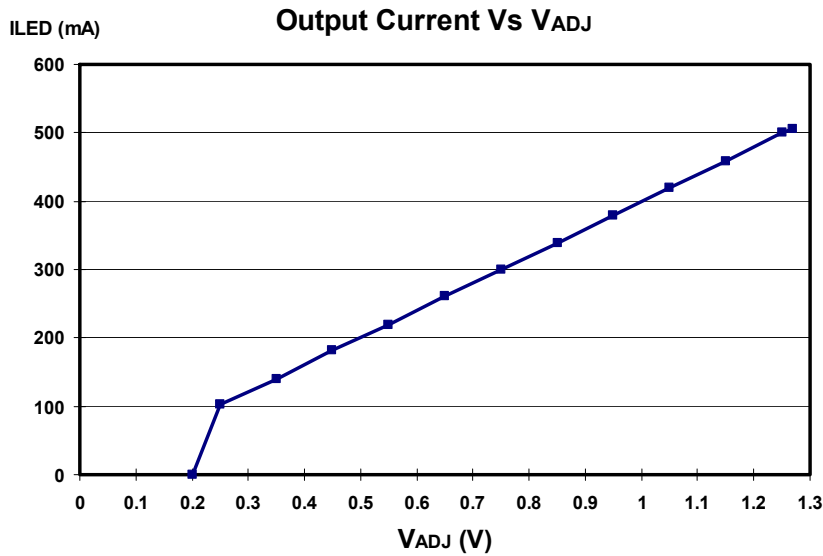
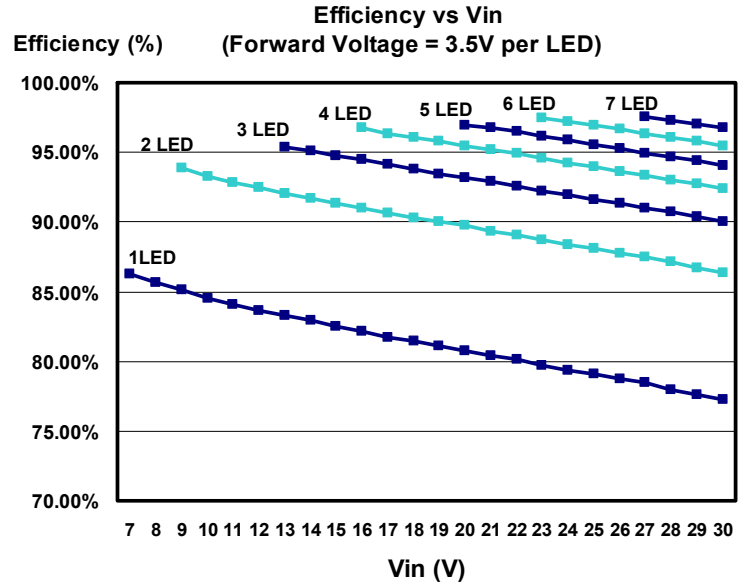
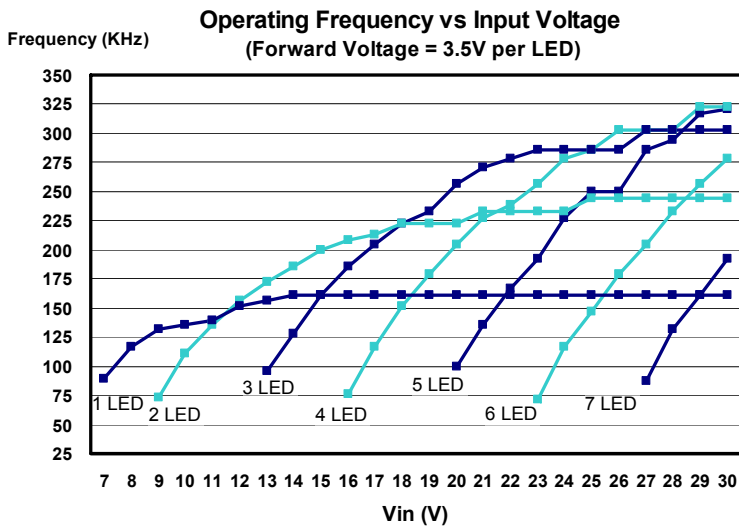

Typical Characteristics: AMLD-6060Z

Operating Frequency vs Input Voltage
(Forward Voltage = 3.5V per LED)

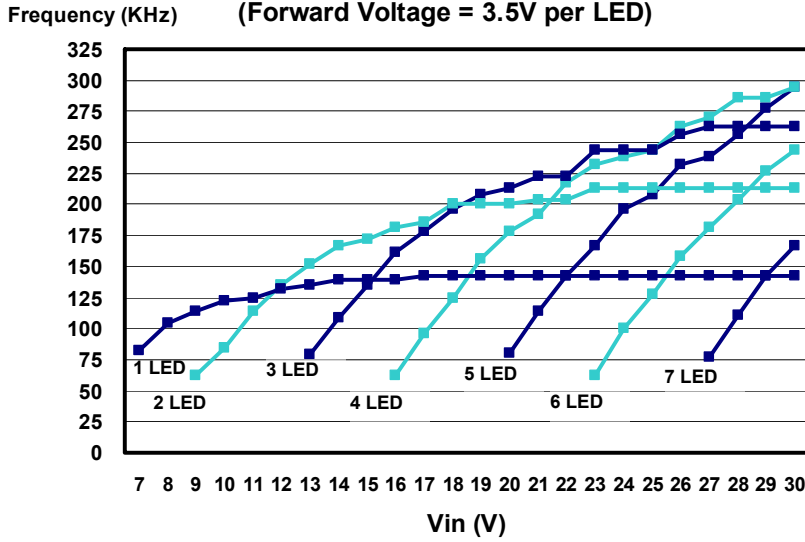

Efficiency vs Vin
(Forward Voltage = 3.5V per LED)

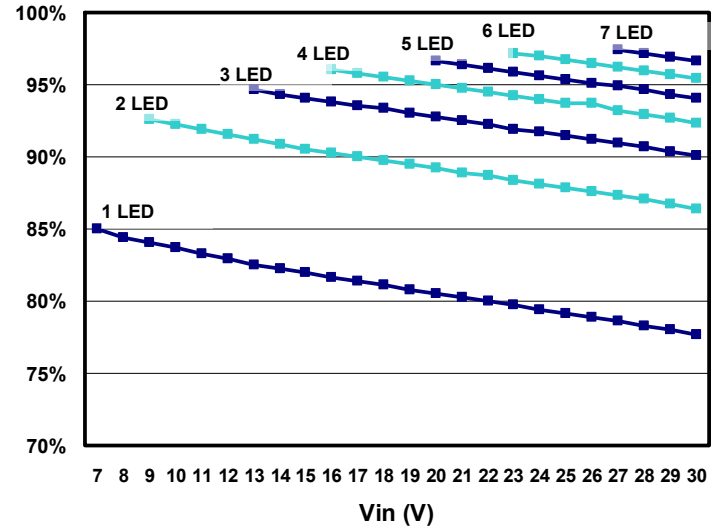

Output Current Vs VADJ

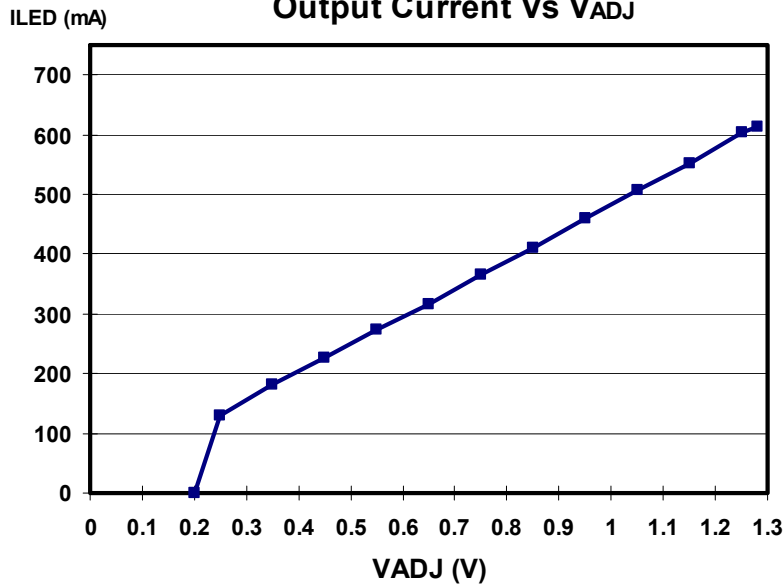

Typical Characteristics: AMLD-6070Z

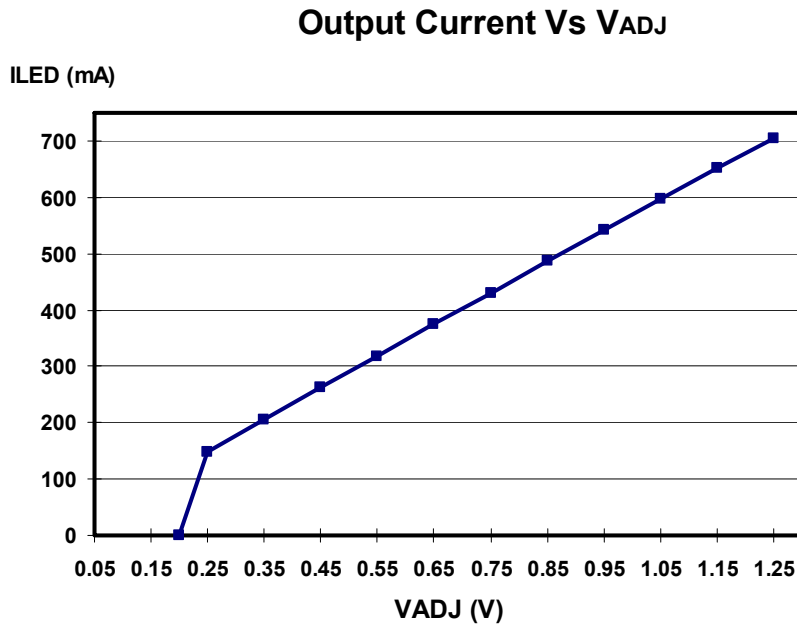
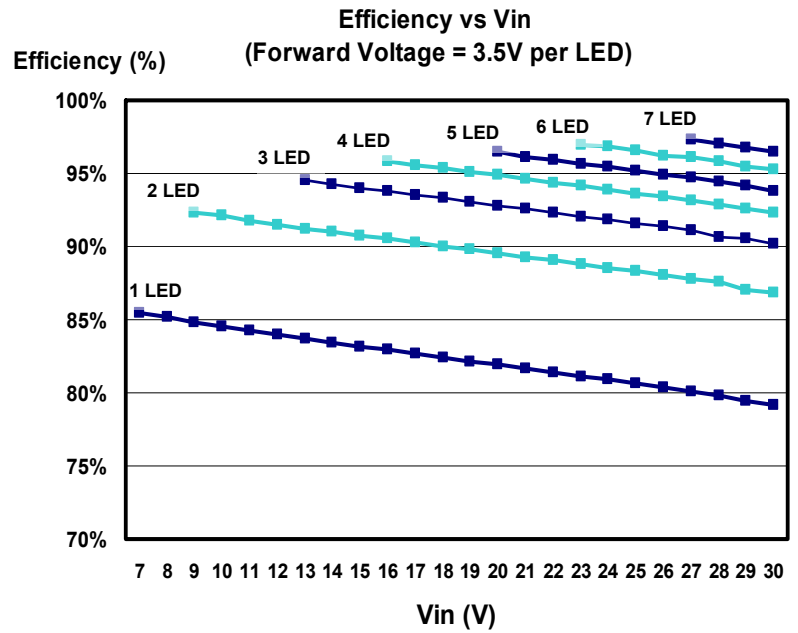
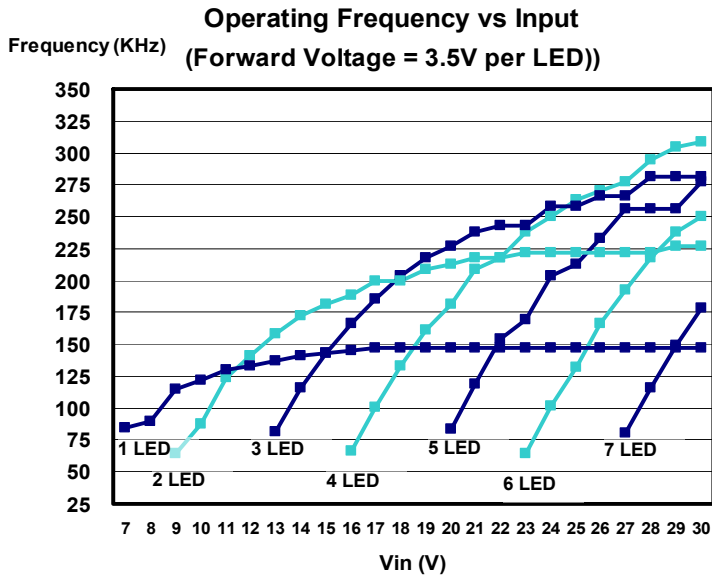

Typical Characteristics: AMLD-60100Z

Operating Frequency vs Input Voltage
(Forward Voltage = 3.5V per LED)

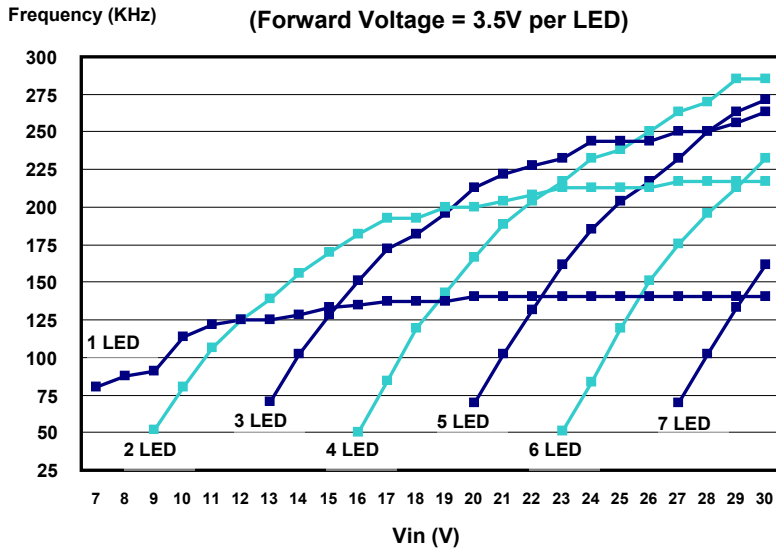

Efficiency vs Vin
(Forward Voltage = 3.5V per LED)

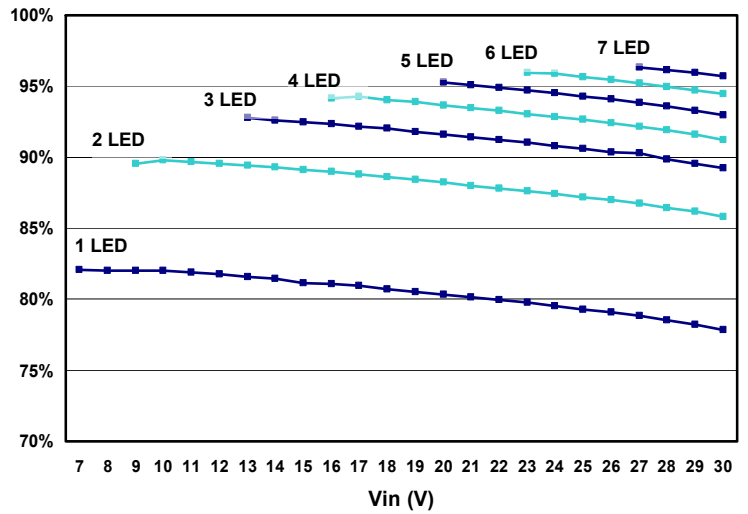

Output Current vs V_{ADJ}

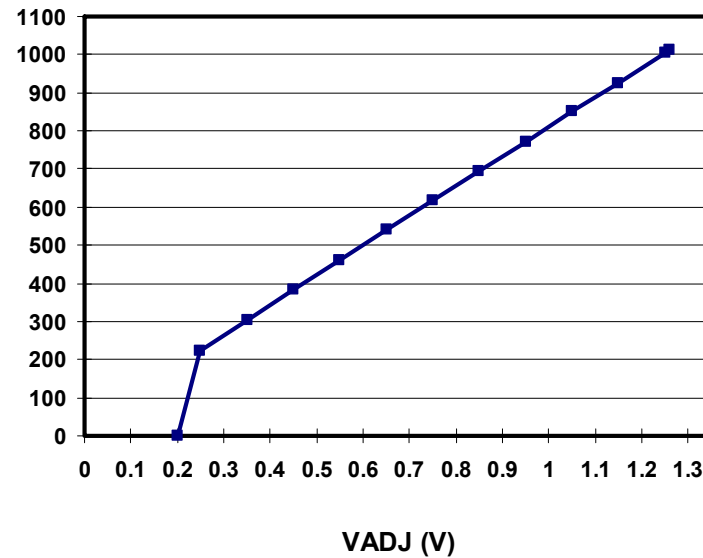

NOTE: 1. Datasheets are updated as needed and as such, specifications are subject to change without notice. Once printed or downloaded, datasheets are no longer controlled by Aimtec; refer to www.aimtec.com for the most current product specifications. 2. Product labels shown, including safety agency certifications on labels, may vary based on the date manufactured. 3. Mechanical drawings and specifications are for reference only. 4. All specifications are measured at an ambient temperature of 25°C, humidity < 75%, nominal input voltage and at rated output load unless otherwise specified. 5. Aimtec may not have conducted destructive testing or chemical analysis on all internal components and chemicals at the time of publishing this document. CAS numbers and other limited information are considered proprietary and may not be available for release. 5. This product is not designed for use in critical life support systems, equipment used in hazardous environments, nuclear control systems or other such applications which necessitate specific safety and regulatory standards other than the ones listed in this datasheet.