

NUD3105D

Integrated Relay, Inductive Load Driver

This device is used to switch inductive loads such as relays, solenoids incandescent lamps, and small DC motors without the need of a free-wheeling diode. The device integrates all necessary items such as the MOSFET switch, ESD protection, and Zener clamps. It accepts logic level inputs thus allowing it to be driven by a large variety of devices including logic gates, inverters, and microcontrollers.

Features

- Provides a Robust Driver Interface Between D.C. Relay Coil and Sensitive Logic Circuits
- Optimized to Switch Relays from 3.0 V to 5.0 V Rail
- Capable of Driving Relay Coils Rated up to 2.5 W at 5.0 V
- Internal Zener Eliminates the Need of Free-Wheeling Diode
- Internal Zener Clamp Routes Induced Current to Ground for Quieter Systems Operation
- Low $V_{DS(on)}$ Reduces System Current Drain
- Pb-Free Package is Available

Typical Applications

- Telecom: Line Cards, Modems, Answering Machines, FAX
- Computers and Office: Photocopiers, Printers, Desktop Computers
- Consumer: TVs and VCRs, Stereo Receivers, CD Players, Cassette Recorders
- Industrial: Small Appliances, Security Systems, Automated Test Equipment, Garage Door Openers
- Automotive: 5.0 V Driven Relays, Motor Controls, Power Latches, Lamp Drivers

INTERNAL CIRCUIT DIAGRAMS

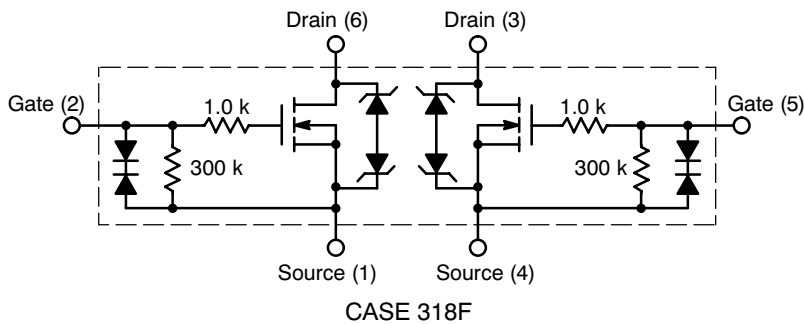

ON Semiconductor®

<http://onsemi.com>

Relay, Inductive Load Driver Silicon SMALLBLOCK™ 0.5 Ampere, 8.0 V Clamp

MARKING DIAGRAM



**SC-74
CASE 318F
STYLE 7**

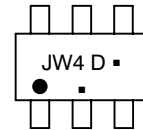

JW4 = Specific Device Code
D = Date Code
▪ = Pb-Free Package

(Note: Microdot may be in either location)

ORDERING INFORMATION

Device	Package	Shipping†
NUD3105DMT1	SC-74	3000/Tape & Reel
NUD3105DMT1G	SC-74 (Pb-Free)	3000/Tape & Reel

†For information on tape and reel specifications, including part orientation and tape sizes, please refer to our Tape and Reel Packaging Specification Brochure, BRD8011/D.

NUD3105D

MAXIMUM RATINGS (T_J = 25°C unless otherwise specified)

Symbol	Rating	Value	Unit
V _{DSS}	Drain to Source Voltage - Continuous	6.0	V _{dc}
V _{GS}	Gate to Source Voltage — Continuous	6.0	V _{dc}
I _D	Drain Current — Continuous	500	mA
E _z	Single Pulse Drain-to-Source Avalanche Energy (T _{Jinitial} = 25°C)	50	mJ
T _J	Junction Temperature	150	°C
T _A	Operating Ambient Temperature	-40 to 85	°C
T _{stg}	Storage Temperature Range	-65 to +150	°C
P _D	Total Power Dissipation (Note 1) Derating Above 25°C	380 1.5	mW mW/°C
R _{θJA}	Thermal Resistance Junction-to-Ambient	329	°C/W

Stresses exceeding Maximum Ratings may damage the device. Maximum Ratings are stress ratings only. Functional operation above the Recommended Operating Conditions is not implied. Extended exposure to stresses above the Recommended Operating Conditions may affect device reliability.

- This device contains ESD protection and exceeds the following tests:
Human Body Model 2000 V per MIL_STD-883, Method 3015.
Machine Model Method 200 V.

TYPICAL ELECTRICAL CHARACTERISTICS (T_J = 25°C unless otherwise noted)

Symbol	Characteristic	Min	Typ	Max	Unit
OFF CHARACTERISTICS					
V _{BRDSS}	Drain to Source Sustaining Voltage (Internally Clamped) (I _D = 10 mA)	6.0	8.0	9.0	V
B _{VGS0}	I _g = 1.0 mA	-	-	8.0	V
I _{DSS}	Drain to Source Leakage Current (V _{DS} = 5.5 V, V _{GS} = 0 V, T _J = 25°C) (V _{DS} = 5.5 V, V _{GS} = 0 V, T _J = 85°C)	- -	- -	15 15	μA
I _{GSS}	Gate Body Leakage Current (V _{GS} = 3.0 V, V _{DS} = 0 V) (V _{GS} = 5.0 V, V _{DS} = 0 V)	5.0 -	- -	35 65	μA
ON CHARACTERISTICS					
V _{GS(th)}	Gate Threshold Voltage (V _{GS} = V _{DS} , I _D = 1.0 mA) (V _{GS} = V _{DS} , I _D = 1.0 mA, T _J = 85°C)	0.8 0.8	1.2 -	1.4 1.4	V
R _{DS(on)}	Drain to Source On-Resistance (I _D = 250 mA, V _{GS} = 3.0 V) (I _D = 500 mA, V _{GS} = 3.0 V) (I _D = 500 mA, V _{GS} = 5.0 V) (I _D = 500 mA, V _{GS} = 3.0 V, T _J = 85°C) (I _D = 500 mA, V _{GS} = 5.0 V, T _J = 85°C)	- - - - -	- - - - -	1.2 1.3 0.9 1.3 0.9	Ω
I _{DS(on)}	Output Continuous Current (V _{DS} = 0.25 V, V _{GS} = 3.0 V) (V _{DS} = 0.25 V, V _{GS} = 3.0 V, T _J = 85°C)	300 200	400 -	- -	mA
g _{FS}	Forward Transconductance (V _{OUT} = 5.0 V, I _{OUT} = 0.25 A)	350	570	-	mMhos

NUD3105D

TYPICAL ELECTRICAL CHARACTERISTICS ($T_J = 25^\circ\text{C}$ unless otherwise noted)

Symbol	Characteristic	Min	Typ	Max	Unit
DYNAMIC CHARACTERISTICS					
C_{iss}	Input Capacitance ($V_{DS} = 5.0\text{ V}, V_{GS} = 0\text{ V}, f = 10\text{ kHz}$)	-	25	-	pF
C_{oss}	Output Capacitance ($V_{DS} = 5.0\text{ V}, V_{GS} = 0\text{ V}, f = 10\text{ kHz}$)	-	37	-	pF
C_{rss}	Transfer Capacitance ($V_{DS} = 5.0\text{ V}, V_{GS} = 0\text{ V}, f = 10\text{ kHz}$)	-	8.0	-	pF

SWITCHING CHARACTERISTICS

Symbol	Characteristic	Min	Typ	Max	Units
t_{PHL} t_{PLH}	Propagation Delay Times: High to Low Propagation Delay; Figure 1 (5.0 V) Low to High Propagation Delay; Figure 1 (5.0 V)	-	25 80	-	nS
t_{PHL} t_{PLH}	High to Low Propagation Delay; Figure 1 (3.0 V) Low to High Propagation Delay; Figure 1 (3.0 V)	-	44 44	-	nS
t_f t_r	Transition Times: Fall Time; Figure 1 (5.0 V) Rise Time; Figure 1 (5.0 V)	-	23 32	-	nS
t_f t_r	Fall Time; Figure 1 (3.0 V) Rise Time; Figure 1 (3.0 V)	-	53 30	-	-

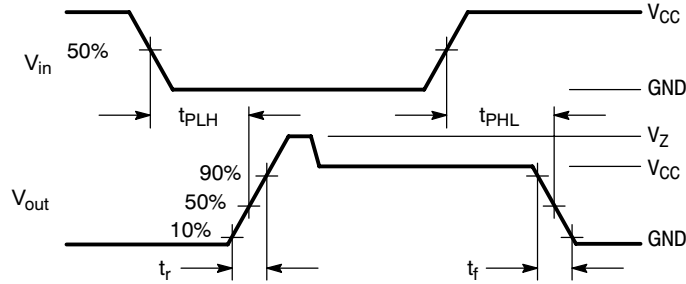

Figure 1. Switching Waveforms

NUD3105D

TYPICAL CHARACTERISTICS

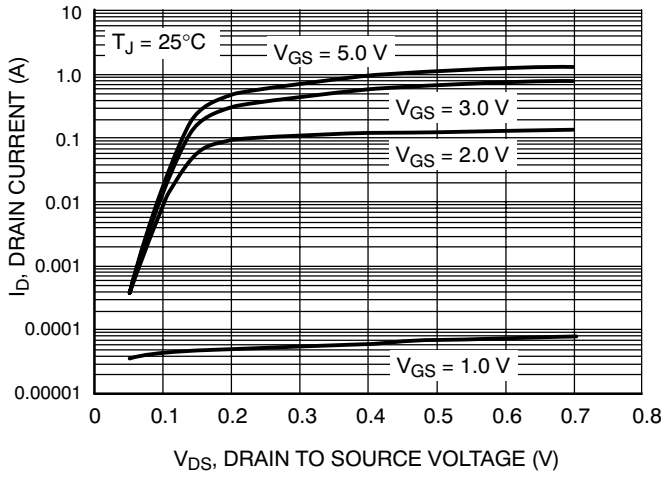

Figure 2. Output Characteristics

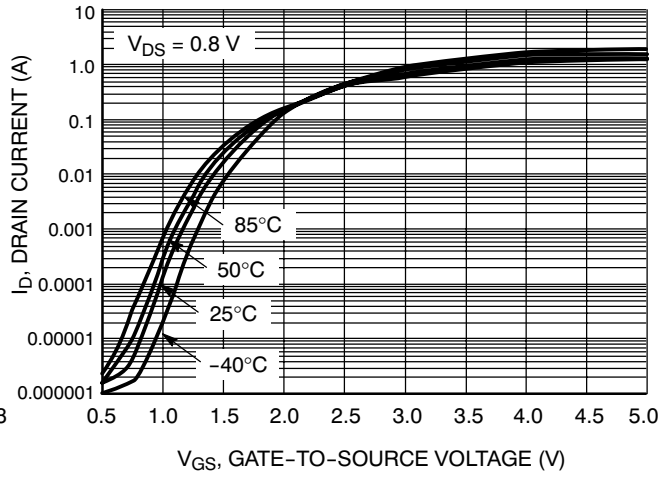

Figure 3. Transfer Function

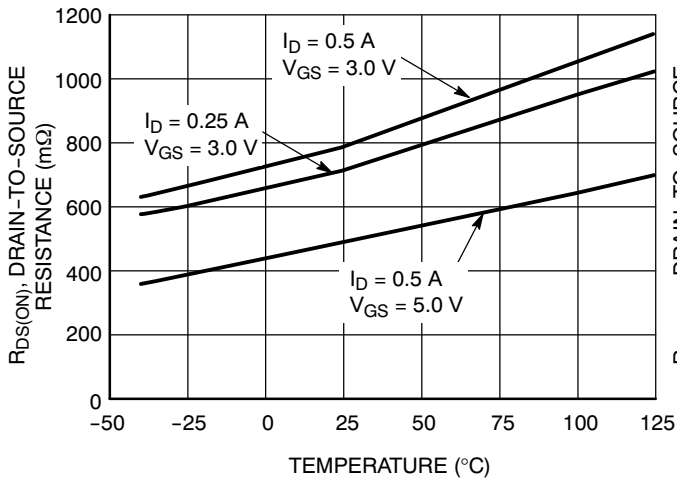

Figure 4. On Resistance Variation vs. Temperature

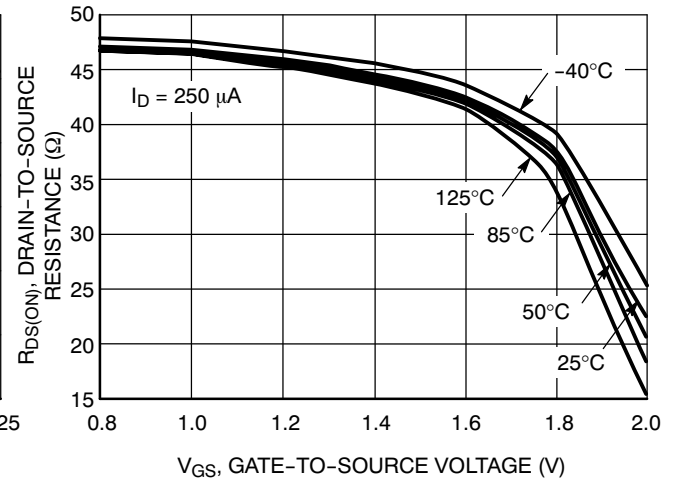

Figure 5. $R_{DS(ON)}$ Variation with Gate-to-Source Voltage

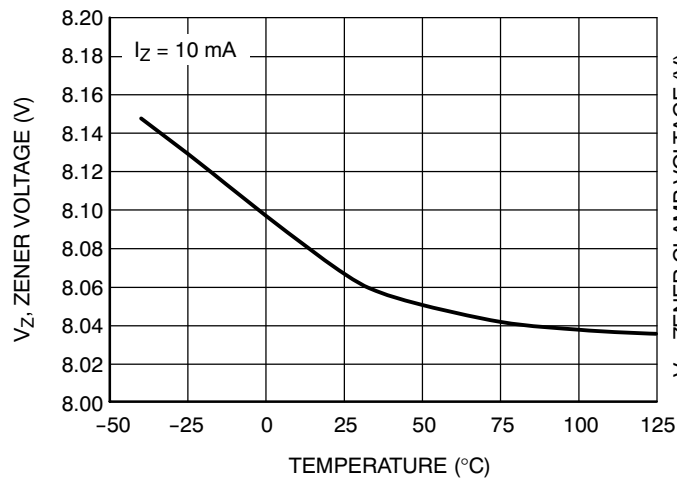

Figure 6. Zener Voltage vs. Temperature

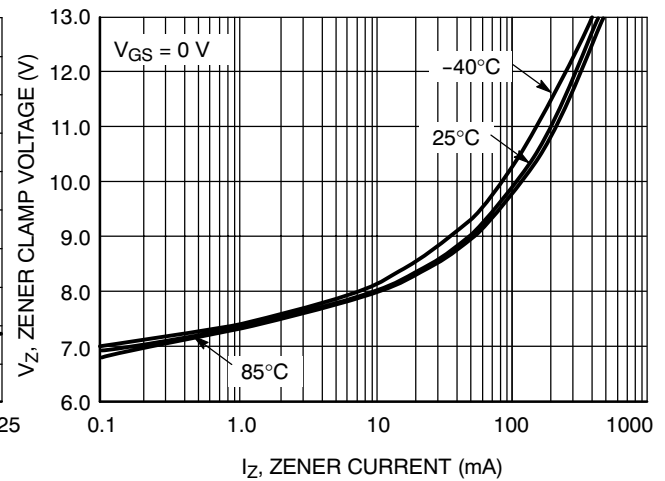

Figure 7. Zener Clamp Voltage vs. Zener Current

NUD3105D

TYPICAL CHARACTERISTICS

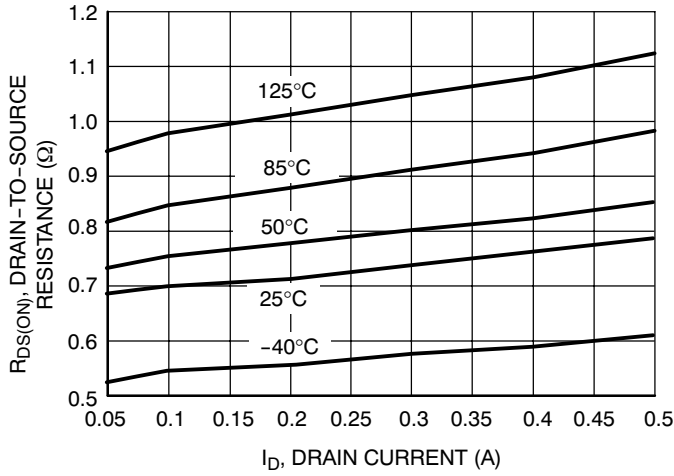

Figure 8. On-Resistance vs. Drain Current and Temperature

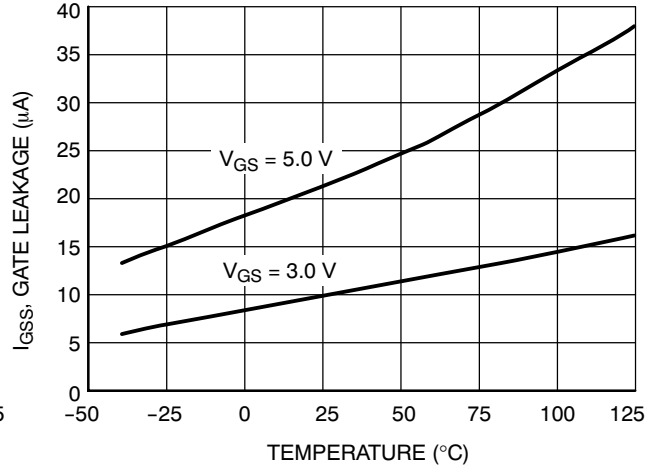

Figure 9. Gate Leakage vs. Temperature

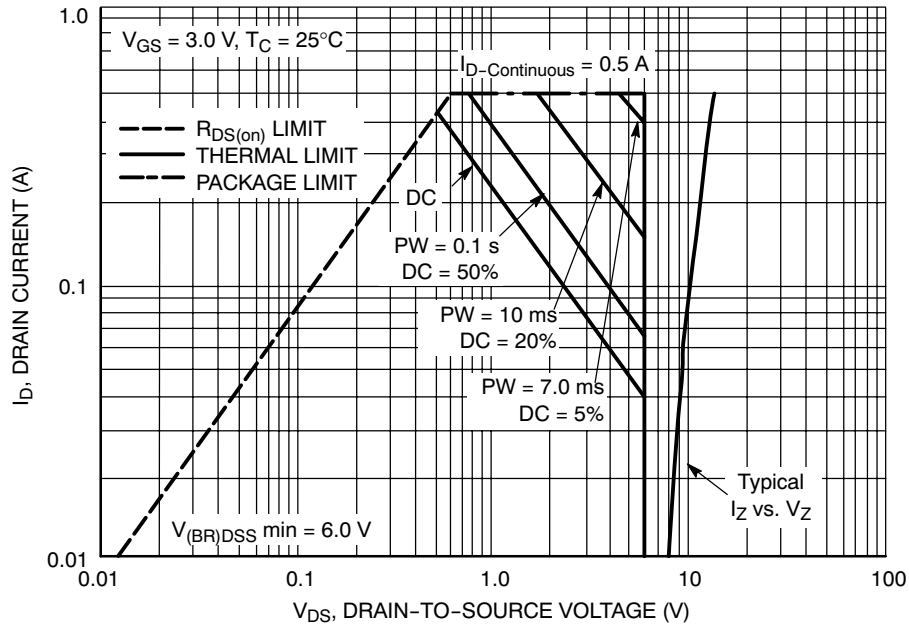

Figure 10. Safe Operating Area for NUD3105DLT1

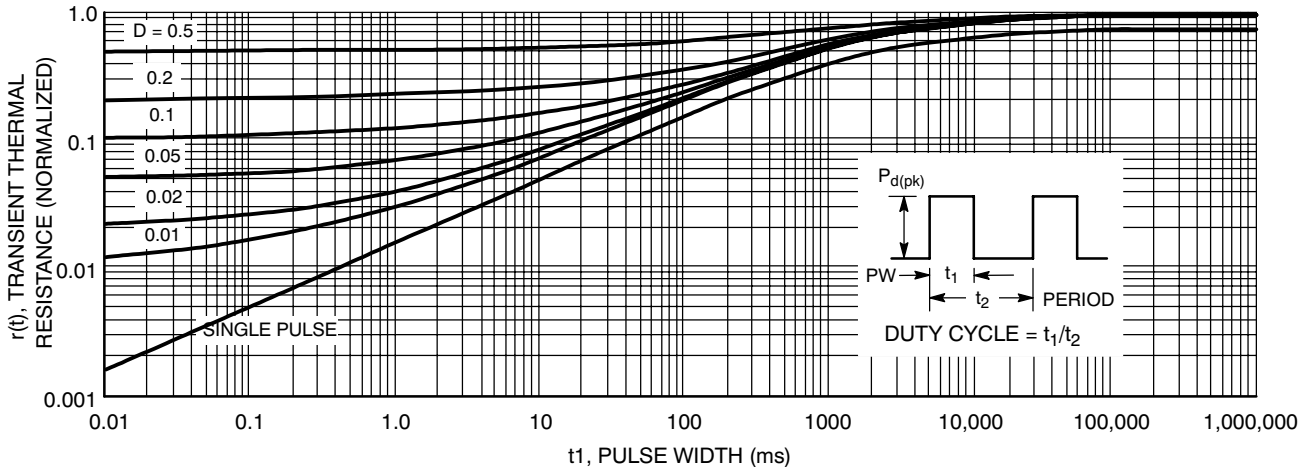

Figure 11. Transient Thermal Response for NUD3105DLT1

NUD3105D

Designing with this Data Sheet

1. Determine the maximum inductive load current (at max V_{CC} , min coil resistance & usually minimum temperature) that the NUD3105D will have to drive and make sure it is less than the max rated current.
2. For pulsed operation, use the Transient Thermal Response of Figure 11 and the instructions with it to determine the maximum limit on transistor power dissipation for the desired duty cycle and temperature range.
3. Use Figures 10 and 11 with the SOA notes to insure that instantaneous operation does not push the device beyond the limits of the SOA plot.
4. Verify that the circuit driving the gate will meet the $V_{GS(th)}$ from the Electrical Characteristics table.
5. Using the max output current calculated in step 1, check Figure 7 to insure that the range of Zener clamp voltage over temperature will satisfy all system & EMI requirements.
6. Use I_{GSS} and I_{DSS} from the Electrical Characteristics table to insure that "OFF" state leakage over temperature and voltage extremes does not violate any system requirements.
7. Review circuit operation and insure none of the device max ratings are being exceeded.

APPLICATIONS DIAGRAMS

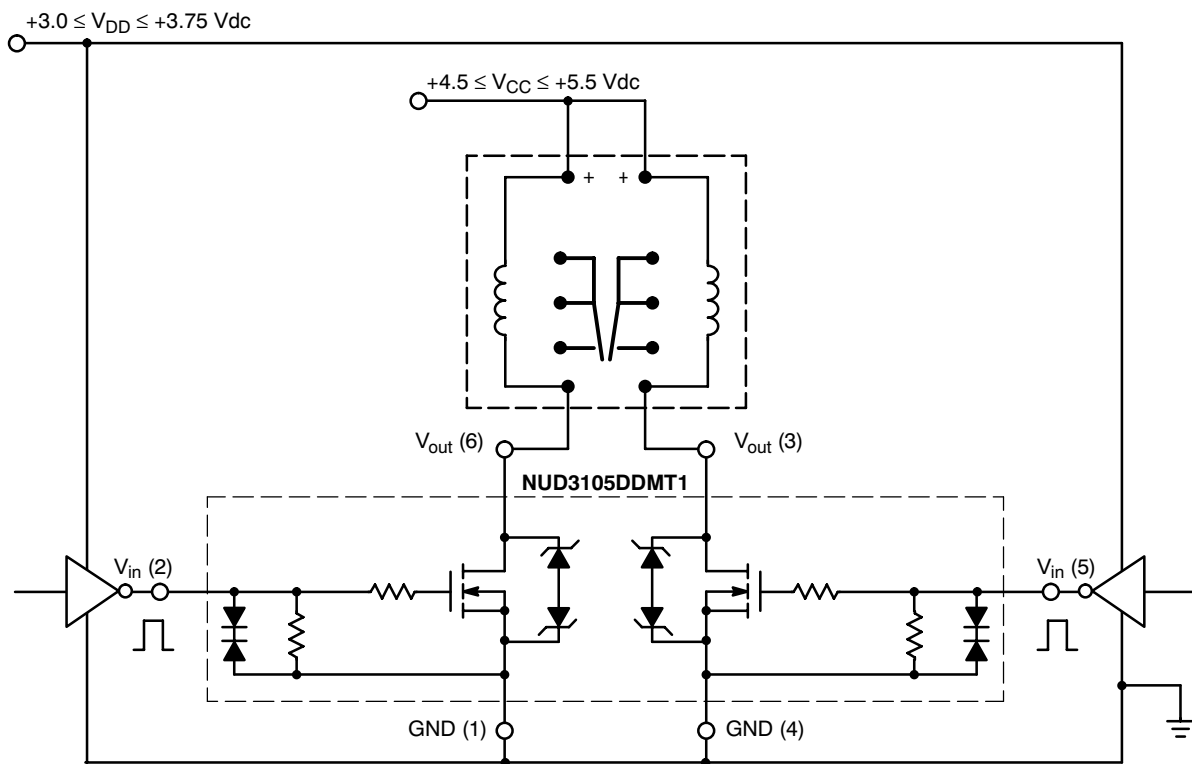

Figure 12. A 200 mW, 5.0 V Dual Coil Latching Relay Application with 3.0 V Level Translating Interface

NUD3105D

Max Continuous Current Calculation

for TX2-5V Relay, $R_1 = 178 \Omega$ Nominal @ $R_A = 25^\circ\text{C}$

Assuming $\pm 10\%$ Make Tolerance,

$R_1 = 178 \Omega * 0.9 = 160 \Omega$ Min @ $T_A = 25^\circ\text{C}$

T_C for Annealed Copper Wire is $0.4\%/^\circ\text{C}$

$R_1 = 160 \Omega * [1 + (0.004) * (-40^\circ - 25^\circ)] = 118 \Omega$ Min @ -40°C

$I_O \text{ Max} = (5.5 \text{ V Max} - 0.25\text{V}) / 118 \Omega = 45 \text{ mA}$

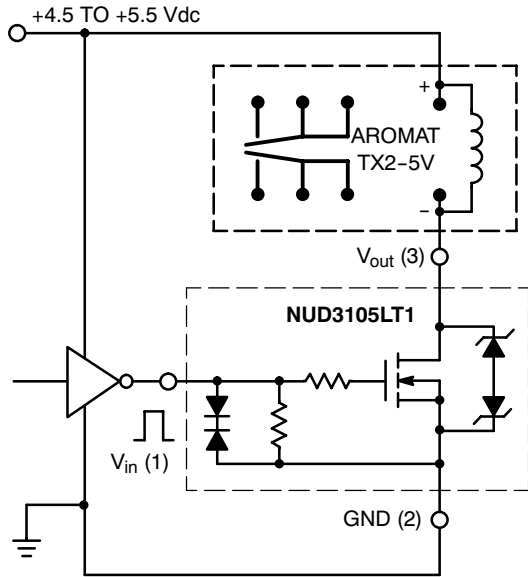

Figure 13. A 140 mW, 5.0 V Relay with TTL Interface

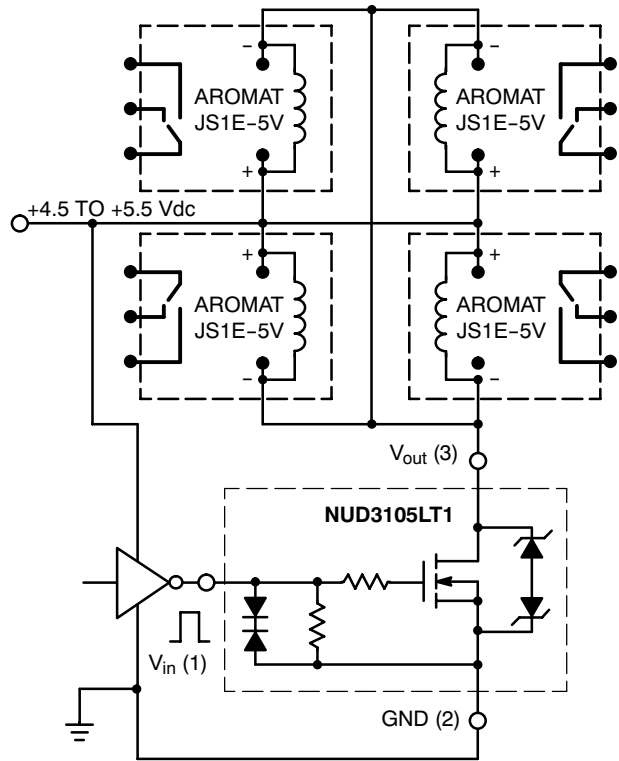
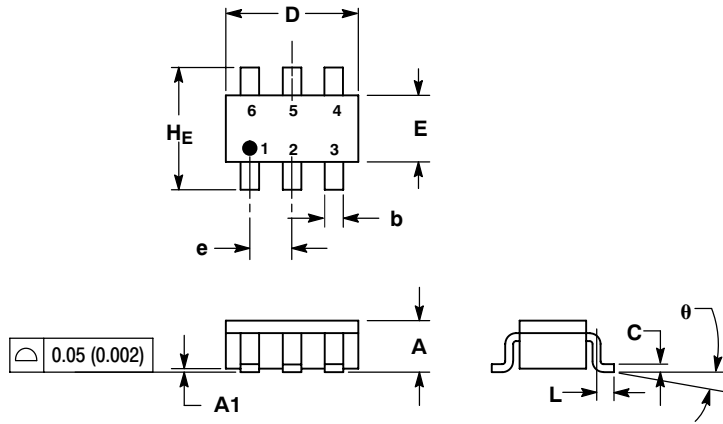

Figure 14. A Quad 5.0 V, 360 mW Coil Relay Bank

NUD3105D

PACKAGE DIMENSIONS

SC-74 CASE 318F-05 ISSUE M



NOTES:

1. DIMENSIONING AND TOLERANCING PER ANSI Y14.5M, 1982.
2. CONTROLLING DIMENSION: INCH.
3. MAXIMUM LEAD THICKNESS INCLUDES LEAD FINISH THICKNESS. MINIMUM LEAD THICKNESS IS THE MINIMUM THICKNESS OF BASE MATERIAL.
4. 318F-01, -02, -03, -04 OBSOLETE. NEW STANDARD 318F-05.

DIM	MILLIMETERS			INCHES		
	MIN	NOM	MAX	MIN	NOM	MAX
A	0.90	1.00	1.10	0.035	0.039	0.043
A1	0.01	0.06	0.10	0.001	0.002	0.004
b	0.25	0.37	0.50	0.010	0.015	0.020
c	0.10	0.18	0.26	0.004	0.007	0.010
D	2.90	3.00	3.10	0.114	0.118	0.122
E	1.30	1.50	1.70	0.051	0.059	0.067
e	0.85	0.95	1.05	0.034	0.037	0.041
L	0.20	0.40	0.60	0.008	0.016	0.024
HE	2.50	2.75	3.00	0.099	0.108	0.118
θ	0°	-	10°	0°	-	10°

STYLE 7:

- PIN 1. SOURCE 1
- GATE 1
- DRAIN 2
- SOURCE 2
- GATE 2
- DRAIN 1

SOLDERING FOOTPRINT*

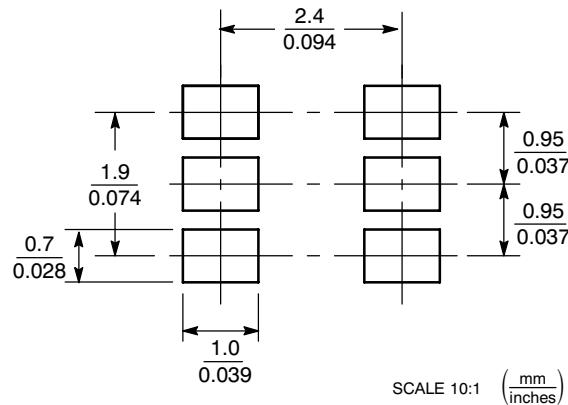

*For additional information on our Pb-Free strategy and soldering details, please download the ON Semiconductor Soldering and Mounting Techniques Reference Manual, SOLDERRM/D.

SMALLBLOCK is a trademark of Semiconductor Components Industries, LLC (SCILLC).

ON Semiconductor and  are registered trademarks of Semiconductor Components Industries, LLC (SCILLC). SCILLC reserves the right to make changes without further notice to any products herein. SCILLC makes no warranty, representation or guarantee regarding the suitability of its products for any particular purpose, nor does SCILLC assume any liability arising out of the application or use of any product or circuit, and specifically disclaims any and all liability, including without limitation special, consequential or incidental damages. "Typical" parameters which may be provided in SCILLC data sheets and/or specifications can and do vary in different applications and actual performance may vary over time. All operating parameters, including "Typicals" must be validated for each customer application by customer's technical experts. SCILLC does not convey any license under its patent rights nor the rights of others. SCILLC products are not designed, intended, or authorized for use as components in systems intended for surgical implant into the body, or other applications intended to support or sustain life, or for any other application in which the failure of the SCILLC product could create a situation where personal injury or death may occur. Should Buyer purchase or use SCILLC products for any such unintended or unauthorized application, Buyer shall indemnify and hold SCILLC and its officers, employees, subsidiaries, affiliates, and distributors harmless against all claims, costs, damages, and expenses, and reasonable attorney fees arising out of, directly or indirectly, any claim of personal injury or death associated with such unintended or unauthorized use, even if such claim alleges that SCILLC was negligent regarding the design or manufacture of the part. SCILLC is an Equal Opportunity/Affirmative Action Employer. This literature is subject to all applicable copyright laws and is not for resale in any manner.

PUBLICATION ORDERING INFORMATION

LITERATURE FULFILLMENT:
Literature Distribution Center for ON Semiconductor
P.O. Box 5163, Denver, Colorado 80217 USA
Phone: 303-675-2175 or 800-344-3860 Toll Free USA/Canada
Fax: 303-675-2176 or 800-344-3867 Toll Free USA/Canada
Email: orderlit@onsemi.com

N. American Technical Support: 800-282-9855 Toll Free
USA/Canada
Europe, Middle East and Africa Technical Support:
Phone: 421 33 790 2910
Japan Customer Focus Center
Phone: 81-3-5773-3850

ON Semiconductor Website: www.onsemi.com
Order Literature: <http://www.onsemi.com/orderlit>

For additional information, please contact your local Sales Representative