

VACUUM FLUORESCENT DISPLAY MODULE

ENGINEERING PROPOSAL

AH108AA

AH108AB

AH108AC

EVALUATION

- ACCEPTED WITHOUT ANY CHANGE
 THE FOLLOWING CHANGE IS REQUIRED

August 20, 2009

VFD MODULE GROUP

Futaba Corporation

ISSUED BY

Hideo Kato

CHECKED BY

CHECKED BY

Kenji Kase

APPROVED BY

Katsunori Kase

Important Safety Notice

Please read this note carefully before using the product.

Warning

- The module should be disconnected from the power supply before handling.
- The power supply should be switched off before connecting or disconnecting the power or interface cables.
- Do not touch the electronic components of the module with any metal objects.
- The VFD used on the module is made of glass and should be handled with care. When handling the VFD, it is recommended that cotton gloves be used.
- The module is equipped with a circuit protection fuse.
- Under no circumstances should the module be modified or repaired. Any unauthorized modifications or repairs will invalidate the product warranty.
- The module should be abolished as the factory waste.

1. GENERAL SPECIFICATIONS

1-1. DIMENSIONS, WEIGHT (Refer to FIGURE-1)

Table-1

Item	Specification	Unit
Outer Dimensions	Refer to outer dimension	mm
Weight	T.B.D	g

1-2. SPECIFICATIONS OF THE DISPLAY PANEL

Table-2

Item	Specification	Unit
Display Area	101.75 (W) × 18.5 (H)	mm
Number of Digit	20 digits (5×8 Dots)×2 rows	–
Character Size (5×7 Dots)	7.74(H)×3.9(W)	mm
Character Pitch	9.64(H)×5.15(W)	mm
Dot Size	1.02(H) × 0.7(W)	mm
Dot Pitch	1.12(H)×0.8(W)	mm
Color of Illumination	Green($\lambda_p=505\text{nm}$)	–

1-3. ENVIRONMENT CONDITIONS

Table-3

Item	Symbol	Min.	Max.	Unit
Operating Temperature	T_{opr}	-20	+70	°C
Storage Temperature	T_{stg}	-20	+70	°C
Operating Humidity (Note)	H_{opr}	20	85	%
Storage Humidity (Note)	H_{stg}	20	90	%
Vibration (10~55Hz)	–	–	4	G
Shock	–	–	40	G

Note) Avoid operations and or storage in moist environmental conditions.

1-4. ABSOLUTE MAXIMUM RATINGS

Table-4

Item	Symbol	Min.	Max.	Unit
Supply voltage (VBUS)	V_{cc1}	–	6.0	V
Supply voltage	V_{cc2}	–	6.0	
Input signal voltage (RS-232C)	V_{IS}	-25	+25	V
Input signal voltage (USB)	V_{IS}	-0.3	+3.6	V

1-5. RECOMMENDED OPERATING CONDITIONS

Table-5

Item	Symbol	Condition	Min.	Typ.	Max.	Unit
Supply voltage (VBUS)	V_{CC1}	–	4.75	5.0	5.25	V
Supply voltage	V_{CC2}	–	4.75	5.0	5.25	V
DATA “1”(MARK)	V_{MARK}	RS-232C	-15	–	-5	V
DATA “0”(SPACE)	V_{SPACE}		5	–	15	V
H-Level Input Voltage	V_{IH}	USB	2.0	–	–	V
L-Level Input Voltage	V_{IL}		–	–	0.8	V
Input Differential Sensitivity	V_{DI}	(D+)-(D-)	0.2	–	–	V

1-6. ELECTRICAL CHARACTERISTICS

Table-6

Item	Symbol	Condition	Min.	Typ.	Max.	Unit
Supply Current	I_{CC}	$V_{CC}=5.0V$	–	350	500	mA
Power Consumption	–	–	–	1.75	2.5	W
H-Level Output Voltage (RS-232C)	V_{OH}	$I_{OH}=-20\mu A$	5	5.4	–	V
L-Level Output Voltage (RS-232C)	V_{OL}	$I_{OL}=-20\mu A$	-5	-5.4	–	V
H-Level Output Voltage (USB)	V_{OH}	$I_{OH}=-200\mu A$	2.8	–	–	V
L-Level Output Voltage (USB)	V_{OL}	$I_{OL}=2mA$	–	–	0.3	V
Luminance	L	All on	250	500	–	cd/m ²

Note) The surge current can be approx.10 times the specified supply current at power on.

2. INTERFACE

2-1. RS-232C

Communication	: Based on RS-232C Asynchronous serial and bi-directional communication
Hand shaking	: RTS control
Data length	: 8 bits (LSB first)
Parity	: Non
Stop bit	: 1 bit
Baud rate	: 9600bps
Signal level	: MARK logic = "1" : SPACE logic = "0"

WRITE-IN TIMING

Serial Input

* The signal level in the following timing chart is described by logic level.
(Not RS232C level)

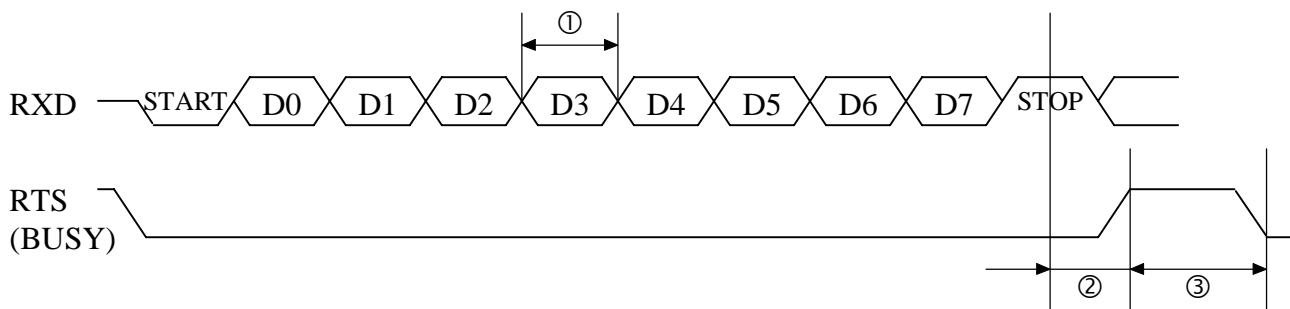

- ① $t(\text{DATA}) = 10^6/9600(\text{bps}) [\mu\text{s}]$
- ② $t(\text{WAIT}) = 200 [\mu\text{s}] \text{ MAX}$
- ③ $t(\text{BUSY}) = 1 [\text{ms}] \text{ MAX}$

A module keeps RTS signal disable (RTS = MARK "1") when processing a reception data, after receiving a character or control code. A data transfer can only be available when RTS signal is enable (RTS = SPACE "0").

2-2. USB

This module will communicate with the USB 2.0 interface (Full speed) if the USB cable is plugged. The communication with USB is based on HID class.

VFD Control Protocol uses HID report. HID report consists of the byte number of sending data and the sending data.

For HID, the report of data (IN or OUT) is fixed-length

The sum of data size and data is declared in HID Report Descriptor.

The data size means the size of sending or receiving data. Max is 63. So the report can send or receive 63bytes data max.

Following is type of report.

Data Size (8)	Data Size (8) [63]
---------------	--------------------

[Example]

Brightness adjustment (100%) and Display 'ABC'

```
06 1B 17 0F 41 42 43 00 00 00 00 00 00 00 00 00 00 00 00 00 00 00 00 00 00 00
00 00 00 00 00 00 00 00 00 00 00 00 00 00 00 00 00 00 00 00 00 00 00 00
00 00 00 00
```

When the host needs the data (IN stage), more than 64bytes can be requested. If the length of response from VFD is over 63bytes, Data Size sets 64. If Data Size is 64, the host must read next data.

2-3. BASIC FUNCTION

The character set has alphabets/numeric/symbols according to JIS6220.

The write-in position is automatically shifted one digit to the right when a character code is received.

If the write-in position is at the right end of the first row, it is moved to the left end of the second row after writing a character.

If the write-in position is at the right end of the second row, it is moved to the left end of the first row after writing a character. Messages on the display will not be changed unless a next character code is received. After receiving the next character code, all of characters on the display are removed. And then the new character is shown at the left end of the first row, and the write-in position is shifted one digit to the right.

* The write-in position behaves as follows, in case the module is processing scroll function (SCR) and a character is written-in to a row where in not defined to the scroll mode.

If the write-in position is at the right end of the row, it is moved to the left end of the same row after writing a character. Messages on the same row is not be changed unless a next character code is received. After receiving the next character code, all of characters at the same row are cleared and the character is shown at the left end of the same row. The write-in position is shifted one digit to the right.

2-4. CONTROL CODE

The control commands are available as follows.

The details are explained on the following pages.

(1) DIM	:	Dimming	:	(04 hex)
(2) BS	:	Back Space	:	(08 hex)
(3) HT	:	Horizontal Tab	:	(09 hex)
(4) CLR	:	Clear	:	(0D hex)
(5) DP	:	Display Position	:	(10 hex)
(6) ALD	:	All Display	:	(0F hex)
(7) BLK	:	Blinking	:	(0A hex)
(8) SCR	:	Scroll	:	(0B hex)
(9) CAL	:	Calendar	:	(0C hex)
(10) DC	:	Cursor Mode	:	(17 hex)
(11) DC1	:	European Font Select	:	(1C hex)
(12) DC2	:	Katakana Font Select	:	(1D hex)
(13) RST	:	Reset	:	(1F hex)
(14) ID	:	Display ID	:	(1B + 5B + 63 hex)

Note) Undefined control code or undefined property code is ignored as invalid data.

(1) DIM (Dimming)

Brightness can be controlled into six levels by using this command

After writing DIM code 04 hex, the second byte represents a level of the brightness corresponded below table.

In case an other data which is not listed on the table below is transferred as the second byte, the data is ignored and also DIM command will be canceled then.

1 byte 1 byte
04 hex + (Dimming data)

Table-7

Brightness	Data
0 %	00 hex
20 %	20 hex
40 %	40 hex
60 %	60 hex
80 %	80 hex
100 %	FF hex

(2) BS (Back Space)

The write-in position is shifted one digit to the left, and the character previously displayed on the digit will be cleared.

When the write-in position is at the left end of the second row, the write-in position is moved to the right end of the first row.

When the write-in position is at the left end of the first row, the write-in position is moved to the right end of the second row.

* While the scroll mode (SCR) is selected, the write-in position is moved to the right end of the same row where is not defined to the scroll mode after receiving BS command if the current write-in position is at the left end of the row.

(3) HT (Horizontal Tab)

The write-in position is shifted one digit to the right.

When the write-in position is at the right end of the first row, the write-in position is moved to the left end of the second row.

When the write-in position is at the right end of the second row, the write-in position is moved to the left end of the first row. (But messages on the display will not be cleared.)

* While the scroll mode (SCR) is selected, the write-in position is moved to the left end of the same row where is not defined to the scroll mode after receiving HT command if the current write-in position is at the right end of the row. (But messages on the row is not cleared.)

(4) CLR (Clear)

All the characters displayed are cleared, and the write-in position is moved to the left end of the first row. But the Dimming level and Cursor Mode will be kept.

* After executing CLR command, the Blink command (BLK) and the scrolling command (SCR) are canceled.

(5) DP (Display Position)

The write-in position can be located at anywhere on the display by using this command. After writing DP code 10 hex, the second byte represents a new write-in position as following values.

	Left end of the row	Right end of the row
1st row	00 hex	13 hex
2nd row	14 hex	27 hex

In case an other data which is out of above position is transferred as the second byte, the data is ignored and also DP command will be canceled then.

* While the scroll mode (SCR) is selected, in case transferred position data as the second byte is located on the row where is defined to the scroll mode, the second byte is ignored and also DP command will be canceled then.

(6) ALD (All Display)

The full dots in all digits are displayed. The dimming level is set at 100%.

To release this mode, the module must be turned off or RST command must be written.

(7) BLK (Blinking)

Blinking character can be realized by using this command.

The command frame consists of following three bytes.

$$\begin{array}{ccc} \text{1 byte} & & \text{1 byte} & & \text{1 byte} \\ \text{0A hex} & + & \text{(Start digit)} & + & \text{(Number of digits)} \end{array}$$

- The second byte represents start digit address of the blinking ON/OFF characters. (The value of the digit address is specified as below.)

Start digit address (hex)

00	01	02	03	04	05	06	07	08	09	0A	0B	0C	0D	0E	0F	10	11	12	13
14	15	16	17	18	19	1A	1B	1C	1D	1E	1F	20	21	22	23	24	25	26	27

- In case 28 ~ FF hex is transferred as the second byte, its data is ignored and also BLK command will be canceled then.
- The third byte represents the number of digits which is specified as the blinking digits.
- In case the number of specified digits overflows the display area, the data is ignored and also BLK command will be canceled then.
- The maximum value of the third byte is the number of digits from the start digits specified by second byte to the right end digit of the second row.
- To make the digits blinking ON or OFF the most significant bit of the third byte must be set to "1" or "0".

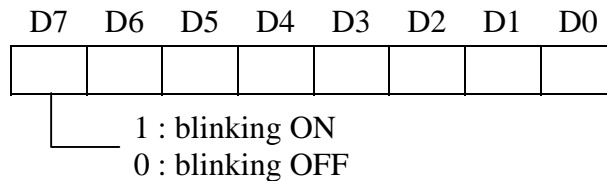

(Note) In case specified digits for blinking overlap an area where has been previously specified, latest command data is prior.

(Note) After executing CLR/ALD/RST, all of blinking digits are initialized as blinking OFF.

(8) SCR (Scrolling message):

SCR command can realize an automatic scrolling message.

Command frame

$$\begin{array}{cccc} \text{1 byte} & & \text{1 byte} & & \text{1 byte} & & \text{60 byte max.} \\ \text{0B(HEX)} & + & \text{(Scroll mode)} & + & \text{(Timer)} & + & \text{(Message data)} \end{array}$$

- A Message starts scrolling after receiving all of data in a command frame. The end of data is identified by the code "END" (02 hex). In case there are some characters on the specified row, once the row is cleared and starts scrolling a message.
- After starting to scroll a message, write-in position moves to the left end of the row where is not defined to the scroll mode.
- The scroll mode can be canceled by CLR/ALD RST commands.

1) Scroll mode set

Selection of the row and direction are specified by the second byte (Scroll mode) as follows.

D7	D6	D5	D4	D3	D2	D1	D0
0	0	0	0	0	0		

1: Scrolling at the first row
0: Scrolling at the second row

1: Scrolling to the right side from the left.

0: Scrolling to the left side from the right.

2) Timer

This third byte specifies an interval time of scrolling. Minimum interval time is 0.1 sec.

Table-9

Interval time	0.1 sec	0.2 sec	-----	12.7 sec
Data	01 hex	02 hex	-----	7F hex

* Initial value is 0.5 sec as 00 hex.

3) Message data

Maximum 60 bytes characters can be displayed with scrolling. These 60 bytes data include ID data which are described as follows and can realize some functions in the scrolling

*ID data

a) PAUSE (01 hex)+(Pause time, 1byte):

The scrolling pauses for a time specified the following one byte.

Table-10

Pause time	0.1 sec	0.2 sec	-----	12.7 sec
Data	01 hex	02 hex	-----	7F hex

* Initial value is 0.5sec as 00 hex.

b) CLEAR (03 hex):

Clear displaying message on the row. Afterwards it continues from the character after Clear ID code 03 hex.

c) END (02 hex):

The END ID code 02 hex must be transferred following the message data.

After receiving END, ID code, the messages restart from the top of the message data.

Note1) In case a message data is 60 bytes without END data, the scrolling message starts again from the top of the message data.

2) In case a message data is 60 bytes and last data is PAUSE, the PAUSE function is canceled.

3) When a scrolling message begins, cursor mode is set for non lighting mode, and all of blinking characters are canceled (no blinking), brightness level is set at 100%.

4) In case the module receives DC/BLK/DIM TBK/SCR/CAL commands while scrolling message, these command are ignored.

5) In case command frame data or message data includes improper data, all of data are ignored and also SCR command will be canceled then.

(9) CAL (Calendar):

The data is displayed with calendar/time format.

* Note that the module does not have real time counting function. This command is only to display data with specified format.

0C hex	Row	2 bytes	1 byte	1 byte	1 byte	1 byte	1 byte
		Year	Month	Day	Hour	Minute	Second

Row : the first row (00 hex) / the second row (14 hex)

ex.) 0C hex + 00 hex + 19 hex + 96 hex + 02 hex + 02 hex + 10 hex + 00 hex + 30 hex

1	9	9	6			2	/		2		1	0	:	0	0	.	3	0		

Note1) When the module receive improper data, the data is ignored and also CAL command will be canceled then.

Note2) 01 to 09 data as month/day/ hour/minute/second does not show “0” character.

Note3) After displaying a calendar on the first row, the write-in position moves to the left end of the second row.
After displaying a calendar on the second row, the write-in position moves to the left end of the first row.

(10) DC (Cursor Mode)

After writing DC mode 17 hex, the second byte represents a selection of the cursor mode shown on the table below.

The cursor which is formed by the 5 dots located the bottom of 5×7 dot matrix character font is always displayed at the write-in position.

1 byte + 1 byte
04 hex (Select Mode Data)

Table-8

Select	Data
Lighting	FF hex
Blinking	88 hex
No Lighting	00 hex

(Note) In case an other data which is not listed on above table is transferred, the data is ignored and also DC command will be canceled then.

1) Lighting Mode

The cursor appears at the write-in position. The character at the write-in position disappears instead. But it will appear again after the write-in position is moved to other position.

2) Blinking Mode

The cursor repeats to blink with 0.3 second period. The character and the cursor at the write-in position is displayed alternately.

3) No Lighting Mode

The cursor is not displayed.

At the power on, “No Lighting” mode is selected.

(11) DC1 (European Font Select)

European Font is selected.

(Refer to Figure-4)

(12) DC2 (Katakana Font Select)

Katakana Font is selected.

(Refer to Figure-3)

At the power on, “DC2” mode is selected.

(13) RST (Reset):

The module is initialized.

All characters displayed are cleared, then the write-in position is set at the left end of the first row. The state of the module becomes the same as power on.

Cursor mode is set for no lighting mode, and the dimming level is set at 100%.

(14) ID (Display ID):

After receiving this command from a host, the module send response data to the host.

The command frame consists of three bytes as follows.

1 byte	+	1 byte	+	1 byte
1B hex		5B hex		63 hex

Note) In case the second or third data is wrong, its data is ignored and also ID command will be canceled then.

After receiving those three bytes, the module send the following response data.

4D hex + 32 hex + 30hex + 32 hex + 4D hex + 44 hex + 31 hex + 35 hex + 48 hex + 41 hex
 (“M”, “2”, “0”, “2”, “M”, “D”, “1”, “5”, “H”, “A”)

2-5. POWER-ON RESET

After a power-on reset, the module initializes to the following conditions:

- 1) All displayed characters and memory are cleared.
- 2) Cursor Mode : No Lighting Mode
- 3) Dimming : 100%
- 4) Character font : DC2 (Katakana Font Select)
- 5) Display position : 1st row, and left end of the row

3. INTERFACE CONNECTION

RS-232C D-SUB 9pin

Table-9

PIN No.	Signal Name	Description
1	–	–
2	RXD	Input
3	TXD	Output
4	–	–
5	GND	Ground
6	–	–
7	RTS	Output
8	CTS	Input
9	–	–

USB

Table-10

PIN No.	Signal Name	Description
1	VBUS(+5V)	USB Power
2	D+	USB D+
3	D–	USB D–
4	GND	GND*

Power EIAJ RC5320A TYPE2

Table-11

PIN No.	Signal Name	Description
1	DC5V	Power*

Note) GND and CN-FGND are connected on the board.

Descriptor Specifications

Standard Device Descriptor

Table-11

Offset	Field	Description	Size [byte]	Value	Comment
0	bLength	Size of descriptor in bytes	1	12H	
1	bDescriptorType	DEVICE Descriptor Type	1	01H	
2	bcdUSB	USB Release Number in BCD	2	0200H	Rev. 2.0
4	bDeviceClass	Class code	1	00H	
5	bDeviceSubClass	Subclass code	1	00H	
6	bDeviceProtocol	Protocol code	1	00H	
7	bMaxPacketSize	Maximum packet size for endpoint zero	1	40H	64 bytes
8	idVendor	Vendor ID	2	1008H	Futaba
10	idProduct	Product ID	2	100BH	M202MD15HA
12	bcdDevice	Device release number in BCD	2	0100H	1.00
14	iManufacturer	Index of string descriptor describing manufacturer	1	01H	
15	iProduct	Index of string descriptor describing product	1	02H	
16	iSerialNumber	Index of string descriptor describing the device's serial number	1	00H	
17	bNumConfigurations	Number of possible configurations	1	01H	

Standard Configuration Descriptor

Table-12

Offset	Field	Description	Size [byte]	Value	Comment
0	bLength	Size of this descriptor in bytes	1	09H	
1	bDescriptorType	CONFIGURATION Descriptor Type	1	02H	
2	wTotalLength	Total length of data returned for this configuration	2	003BH	59 bytes
4	bNumInterfaces	Number of interfaces supported by this configuration	1	01H	
5	bConfigurationValue	Value to use as an argument	1	01H	
6	iConfiguration	Index of string descriptor describing this configuration	1	00H	
7	bmAttributes	Configuration characteristics	1	C0H	Bus powered Disable Remote Wakeup
8	MaxPower	Maximum power consumption	1	FAH	500mA

Interface Descriptor (#1) VFD Control

Table-13

Offset	Field	Description	Size [Byte]	Value	Comment
0	bLength	Size of this descriptor in bytes	1	09H	
1	bDescriptorType	INTERFACE Descriptor Type	1	04H	
2	bInterfaceNumber	Number of this interface	1	00H	VFD Control
3	bAlternateSetting	Value used to select this alternate setting	1	00H	
4	bNumEndpoints	Number of endpoints used by this interface	1	01H	
5	bInterfaceClass	Class code	1	03H	HID
6	bInterfaceSubClass	Subclass code	1	00H	
7	bInterfaceProtocol	Protocol code	1	00H	
8	iInterface	Index of string descriptor describing this interface	1	02H	

HID Descriptor (#1)

Table-14

Offset	Field	Description	Size [Byte]	Value	Comment
0	bLength	Size of HID descriptor	1	09H	
1	bDescriptorType	HID descriptor type	1	21H	HID Class descriptor
2	bcdHID	HID class specification	2	0110H	HID Revision 1.10
4	bCountry	Country code of the localized hardware	1	00H	Not defined
5	bNumDescriptors	Number of class descriptors	1	01H	1 report descriptor
6	bReportType	Type of class descriptor	1	22H	REPORT descriptor
7	wReportLength	Descriptor length	2	0027H	39 bytes

Endpoint Descriptor (#1)

Table-15

Offset	Description	Size [Byte]	Value	Comment
0	Size of this descriptor in bytes	1	07H	
1	ENDPOINT Descriptor Type	1	05H	
2	The address of the endpoint on the USB device described by this descriptor	1	83H	EP3, IN
3	The endpoint's attributes	1	03H	Interrupt Transfer
4	Maximum packet size this endpoint	2	0040H	
6	Interval for polling endpoint for data transfers	1	04H	4[ms]

HID Report Descriptor(#1) Table-16

Part	Value (HEX)
Usage Page(Vendor-defined),	06 7F FF
Usage (VFD_CONTROL),	09 06
Collection (Application),	A1 01
Usage (VFD_DATA_SIZE),	09 80
Logical Minimum (0),	15 00
Logical Maximum (255),	26 FF 00
Report Size (8),	75 08
Report Count (1),	95 01
Input (Data,Variable,Absolute),	81 02
Usage (VFD_DATA_INPUT),	09 81
Report Count (63),	95 3F
Input (Data,Variable,Absolute),	81 02
Usage (VFD_DATA_SIZE),	09 80
Report Count (1),	95 01
Output (Data,Variable,Absolute),	91 02
Usage (VFD_DATA_OUTPUT),	09 82
Report Count (63),	95 3F
Output (Data,Variable,Absolute),	91 02
End Collection	C0

Table-17

Description	Value (HEX)
VFD_CONTROL	06
VFD_DATA_SIZE	80
VFD_DATA_INPUT	81
VFD_DATA_OUTPUT	82

String Descriptor

Table-18

No	Part	Description	Value
No.0	bLength	Length	0x04
	bDescriptorType	type=STRING	0x03
	bSting	LangID (English US)	0x0409
No.1	length	Length	0x0E
	bDescriptorType	Type=STRING	0x03
	bSting	Manufacturer	Futaba
No.2	bLength	Length	0x22
	bDescriptorType	Type=STRING	0x03
	bSting	Product	20x2 VFD DISPLAY

AH108AA Mechanical drawing

FIGURE-1

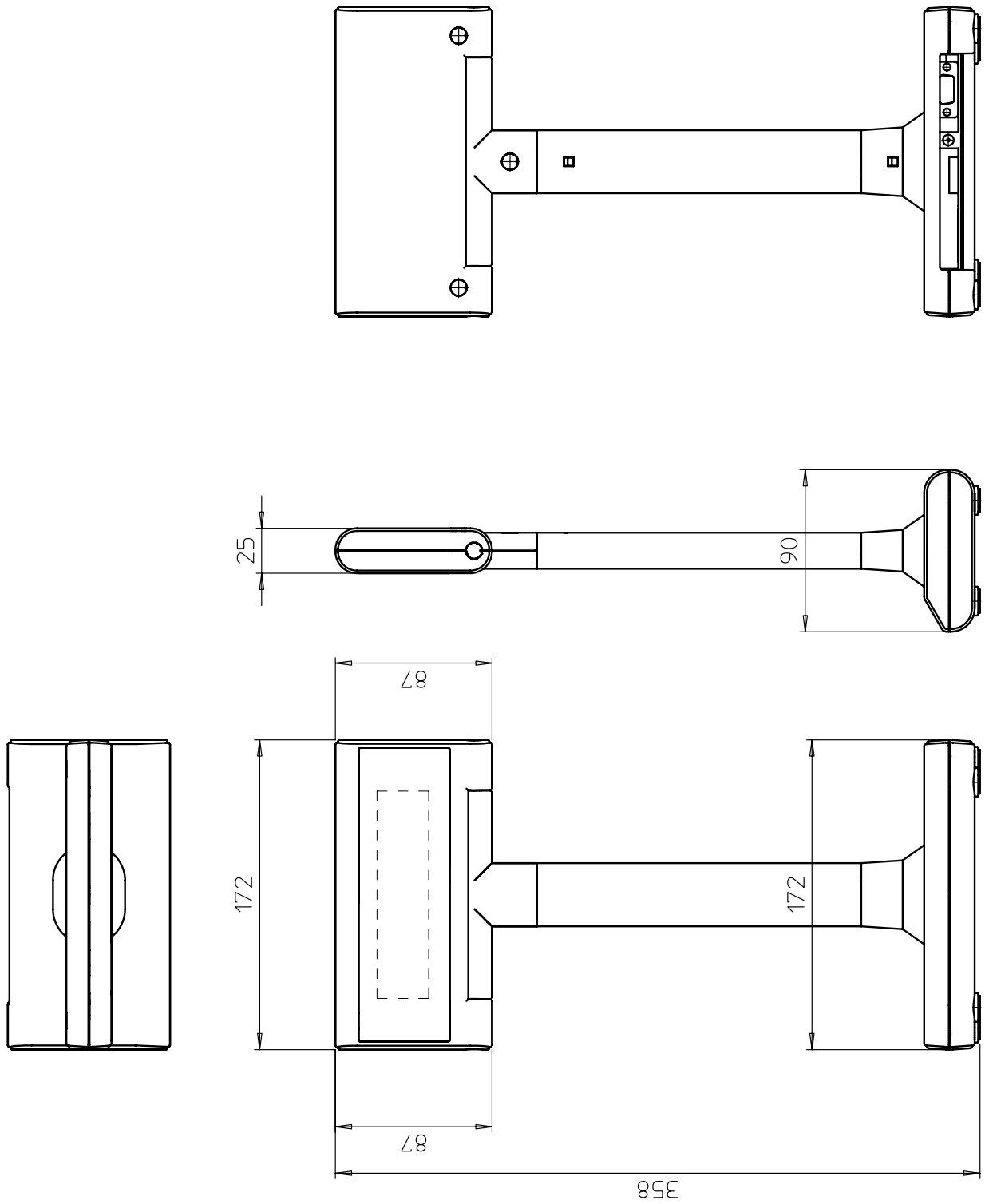

AH108AB Mechanical drawing

FIGURE-2

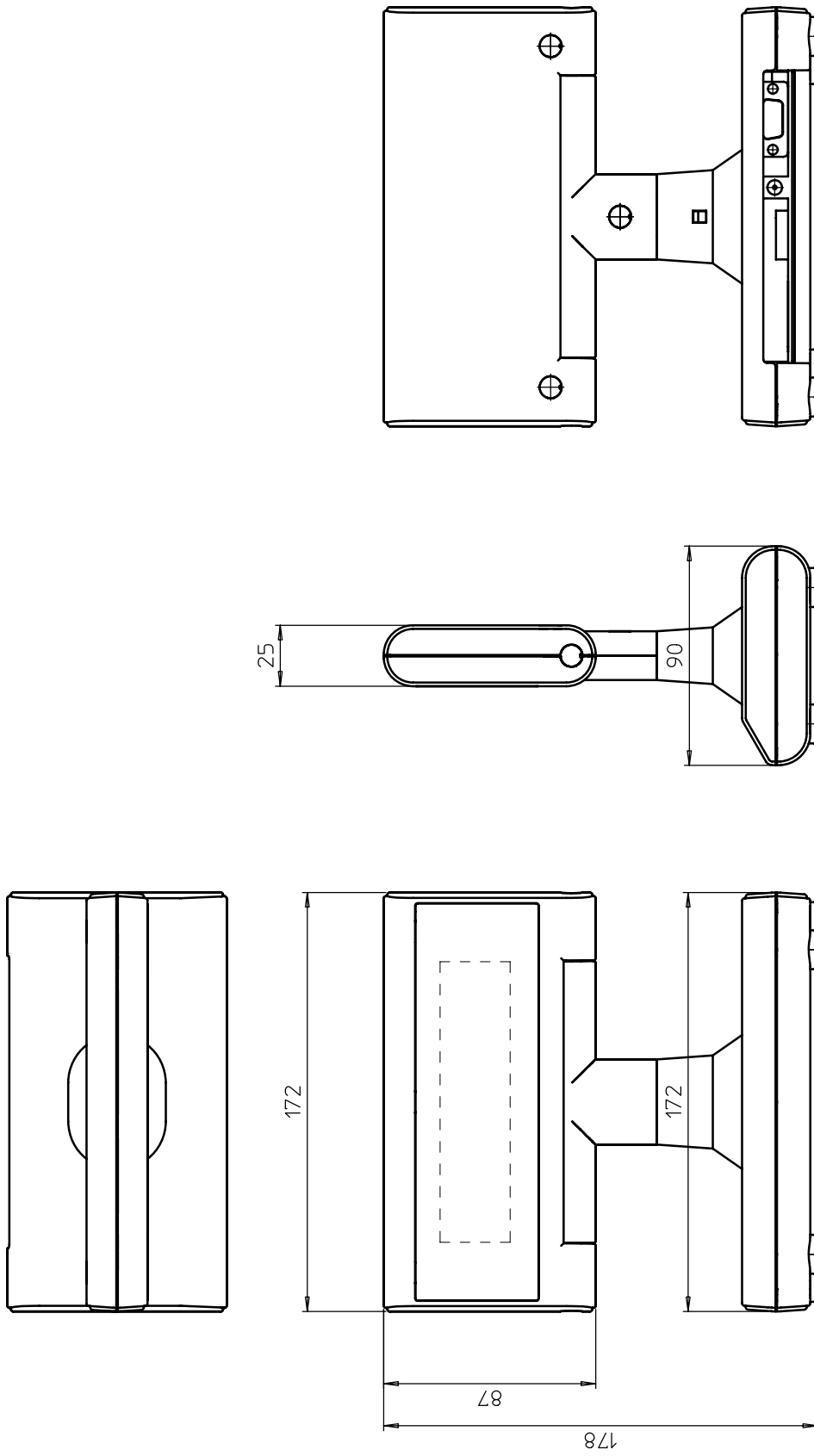

AH108AC Mechanical drawing

FIGURE-3

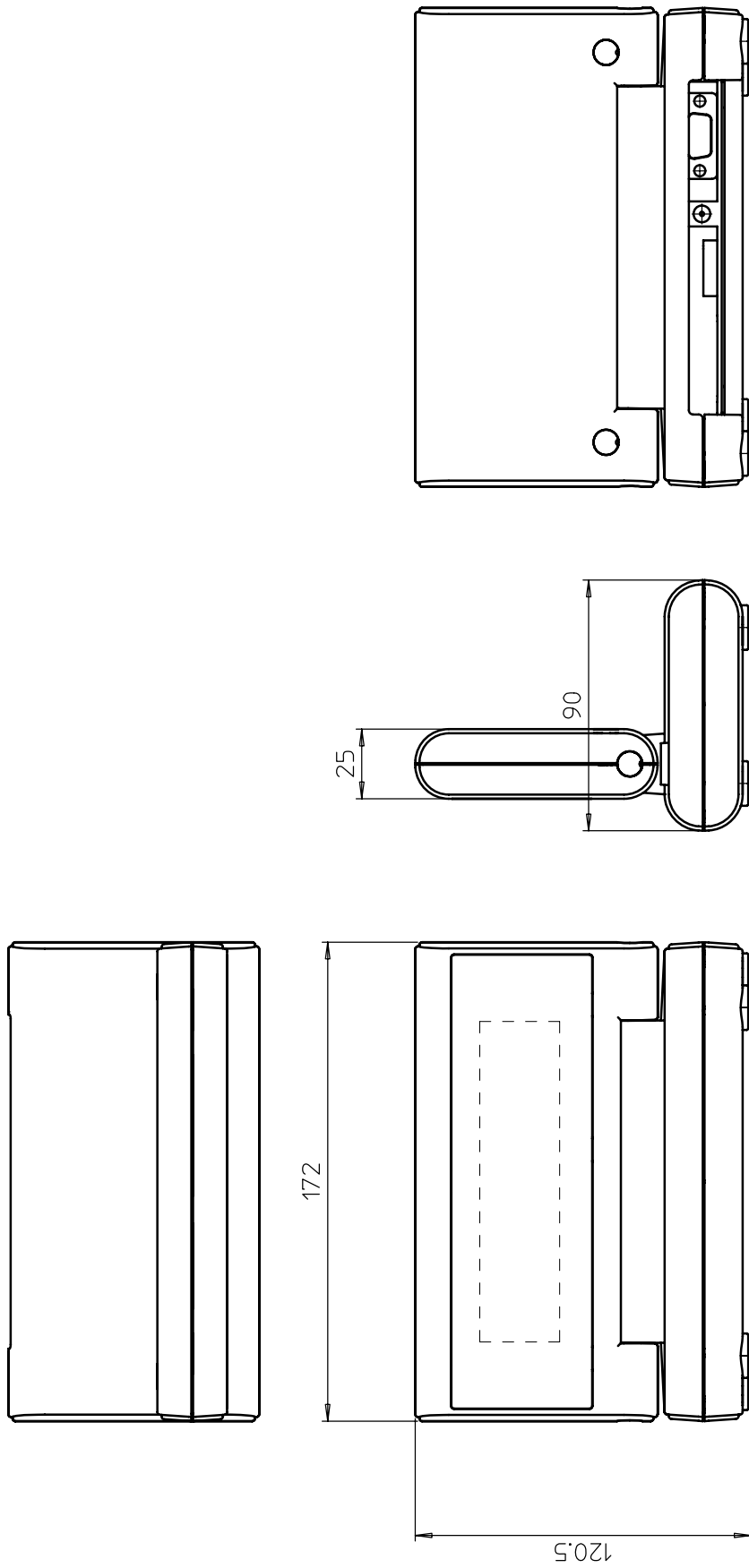

AH108A* CIRCUIT BLOCK DIAGRAM

FIGURE-4

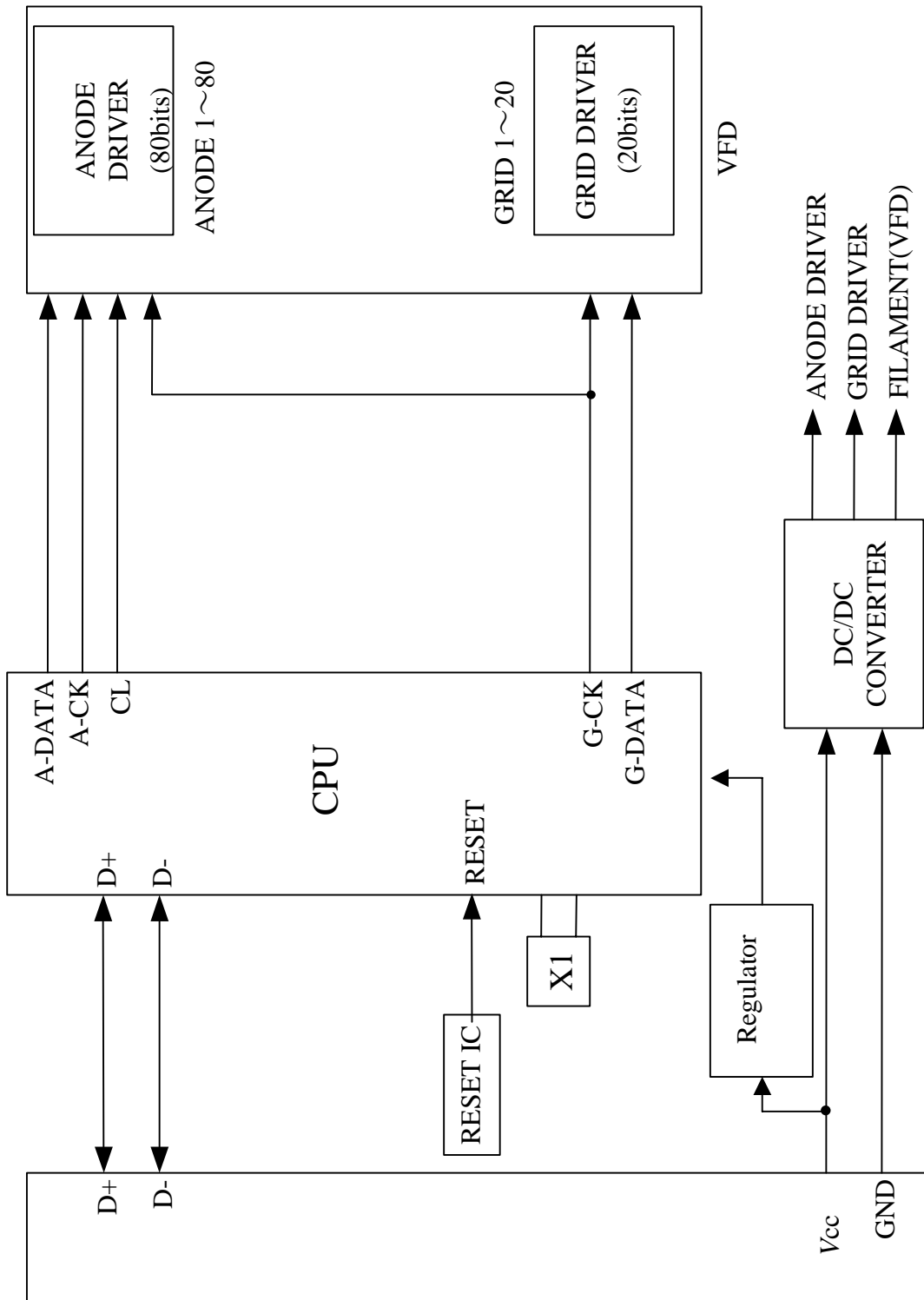

AH108A* CHARACTER DISPLAY CODE (Katakana Font)

APPENDIX-1

D3 D2 D1 D0	D7	0	0	0	0	0	0	0	0	1	1	1	1	1	1	1	
	D6	0	0	0	0	1	1	1	1	0	0	0	0	1	1	1	
	D5	0	0	1	1	0	0	1	1	0	0	1	1	0	0	1	
	D4	0	1	0	1	0	1	0	1	0	1	0	1	0	1	0	
0 0 0 0	0		DP	SP	0	a	P	`	P	a	E	I	-	g	E	↑	↘
0 0 0 1	1	ID PAUSE		!	1	A	Q	a	q	B	S	g	フ	チ	△	↓	↘
0 0 1 0	2	ID END		"	2	B	R	b	r	r	e	r	イ	ウ	×	〒	*
0 0 1 1	3	ID CLEAR		#	3	C	S	c	s	d	e	o	u	ウ	テ	エ	ウ
0 1 0 0	4	DIM		\$	4	D	T	d	t	e	l	\	工	ト	ト	A	R
0 1 0 1	5			%	5	E	U	e	u	n	又	=	オ	カ	工	日	〒
0 1 1 0	6			&	6	F	V	f	v	θ	α	フ	カ	ニ	ヨ	A	←
0 1 1 1	7	DC		'	7	G	W	g	w	λ	-	フ	チ	又	ウ	火	→
1 0 0 0	8	BC		(8	H	X	h	x	P	2	イ	ウ	ホ	リ	*	△
1 0 0 1	9	HT)	9	I	Y	i	y	π	3	→	フ	ル	*	ö	
1 0 1 0	A	BLK		*	:	J	Z	j	z	P	*	工	コ	ル	△	ü	
1 0 1 1	B	SCR		+	:	K	L	k	l	6	¼	*	ウ	ヒ	口	ト	△
1 1 0 0	C	CAL	DC1	,	<	L	*	l	l	7	√	フ	ヨ	フ	フ	△	ö
1 1 0 1	D	CLR	DC2	-	=	M	I	m	ı	φ	r	工	又	ノ	ノ	ノ	ü
1 1 1 0	E			.	>	N	^	n	˘	Q	±	ヨ	エ	ホ	ノ	≡	△
1 1 1 1	F	ALD	RST	/	?	O	_	o	■	Σ	■	ウ	ウ	フ	□		SP

SP : SPACE

AH108A* CHARACTER DISPLAY CODE (European Font)

APPENDIX-2

	0	1	2	3	4	5	6	7	8	9	A	B	C	D	E	F
0		DP		0	o	P	`	F	€	u		"	À	Ä	Å	Û
1	ID PAUSE		!	l	l	o	a	g	*	'	i	±	À	Ä	Å	Û
2	ID END		"	2	R	r	,	'	€	2	À	Ä	Å	Û		
3	ID CLEAR		*	3	S	s	ç	ç	€	3	À	Ä	Å	Û		
4	DIM		*	4	T	t	„	„	€	4	À	Ä	Å	Û		
5			5	E	e	u	€	5	À	Ä	Å	Û		
6			6	F	f	v	t	-	€	6	À	Ä	Å	Û		
7		DC	7	G	g	u	+	-	€	7	À	Ä	Å	Û		
8	BC		8	H	h	x	ˆ	ˆ	€	8	À	Ä	Å	Û		
9	HT		9	I	i	w	z	z	€	9	À	Ä	Å	Û		
A	BLK		*	J	j	z	z	z	€	A	À	Ä	Å	Û		
B	SCR		+	K	k	z	z	z	€	B	À	Ä	Å	Û		
C	CAL	DC1	,	L	l	l	l	l	€	C	À	Ä	Å	Û		
D	CLR	DC2	-	M	m	z	z	z	€	D	À	Ä	Å	Û		
E			z	N	n	z	z	z	€	E	À	Ä	Å	Û		
F	ALD	RST	/	?	O	o			€	F	À	Ä	Å	Û		

4. OPERATING RECOMMENDATIONS

- 4-1. Since VFDs are made of glass material.
Avoid applying excessive shock or vibration beyond the specifications for the module.
Careful handling is essential, especially the exhaust chip when mounting the module.
- 4-2. Applying lower voltage than the specified may cause non activation for selected pixels.
Conversely, higher voltage may cause may non-selected pixel to be activated.
- 4-3. If the start up time of the supply voltage is slow, the controller may not be reset.
The supply voltage must be risen up to specified voltage level within 30msec.
- 4-4. DC/DC converter is equipped on the module, the surge current may be approximately 10 times the specified supply current at the power on.
- 4-5. Avoid using the module where excessive noise interface is expected. Noise affects the interface signal and cause improper operation.
Keep the length of the interface cable less than 50cm (When the longer cable is required, please contact FUTABA engineering.).
- 4-6. When fixed pattern is displayed for long time, you may see uneven luminance.
It is recommended to change the display patterns sometimes is order keep best display quality.