



### Features

- CPC5712 Outputs:
  - Two Independent Programmable Level Detectors with Programmable Hysteresis
  - Fixed-Level Polarity Detector with Hysteresis
  - Differential Linear Output
- Minimum External Components
- Excellent Common-Mode Rejection Ratio (CMRR)  $\geq 55\text{dB}$
- Application circuits meet isolation requirements of worldwide telephony standards
- Worldwide telephone network compatibility
- 3.0V to 5.5V Operation
- High differential input impedance; very low common-mode input impedance
- Fixed Gain
- CMOS Logic Level (TTL Compatible) output
- Small QSOP 16-Lead package

### Applications

- VoIP Gateways, IP-PBX, xDSL
- TIP/RING Monitoring
  - Line-In-Use Detection
  - Polarity Detection for Caller ID, Enhanced 911
  - Battery Detection, PSTN Check
- Non-telephony voltage level detection applications
  - Instrumentation
  - Industrial Controls

### Description

The CPC5712 is a special purpose Phone Line Monitor with Detectors (PLMD) integrated circuit that is used in various high-voltage telephony applications such as VoIP gateways and IP-PBXs. The device monitors the TIP/RING potential through a high-impedance divider (resistor isolation) to derive two programmable signal level detects, polarity information, and a scaled representation of the phone line voltages. In use, the resistor divider and the high input impedance of the CPC5712 make the circuit practically undetectable on the line.

The two voltage-level detects are programmed with external resistors, which gives the designer complete freedom with respect to line voltage detection levels. The level settings also have programmable hysteresis to prevent false triggering conditions. Detection of these levels allows the user to determine the condition of the line.

This device can also be used in non-telephony applications such as instrumentation and industrial controls, especially when a low-level differential level needs to be detected in the presence of a large common-mode voltage.

### Ordering Information

Part	Description
CPC5712U	PLMD, 16-Lead QSOP (100/tube)
CPC5712UTR	PLMD, 16-Lead QSOP (2000/Reel)

Figure 1 CPC5712 PLMD With Support Components

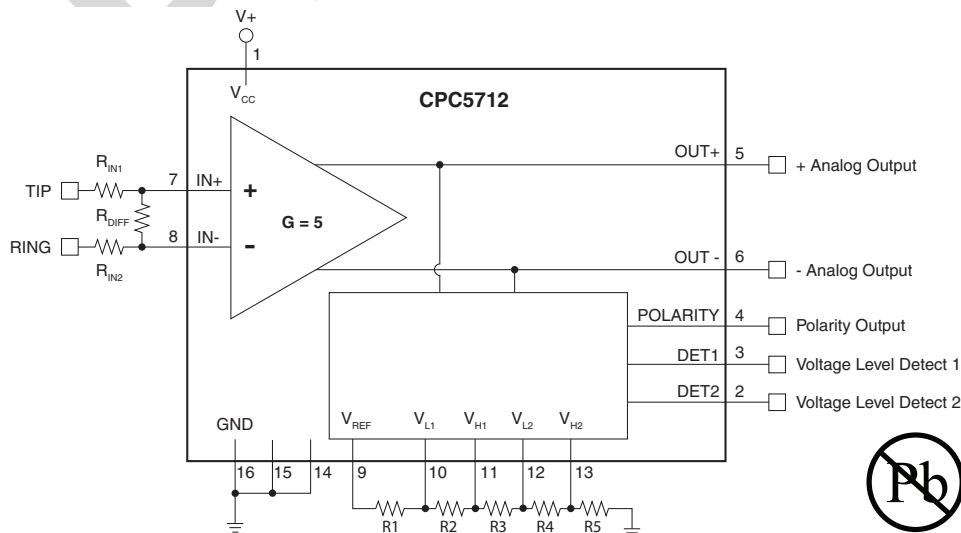

<b>1. Specifications</b> .....	<b>3</b>
1.1 Package Pinout .....	3
1.2 Pin Description .....	3
1.3 Absolute Maximum Ratings .....	3
1.4 Recommended Operating Conditions .....	3
1.5 Electrical Characteristics .....	4
<b>2. Functional Description</b> .....	<b>5</b>
2.1 Overview .....	5
2.2 Line Side Interface .....	5
2.3 Monitor Output .....	5
2.4 Detector Outputs .....	5
2.5 Detector Threshold Operation .....	6
2.6 Power Connections .....	6
<b>3. Design Example</b> .....	<b>7</b>
3.1 Line Interface .....	7
3.2 Voltage Detector Design .....	8
3.2.1 Calculate Resistor Values .....	8
3.2.2 Verify Resistor Selection .....	8
<b>4. Manufacturing Information</b> .....	<b>9</b>
4.1 Mechanical Dimensions and Printed Circuit Board Land Pattern .....	9
4.2 Tape and Reel Packaging .....	9
4.3 Soldering .....	10
4.4 Washing .....	10

Preliminary

## 1. Specifications

### 1.1 Package Pinout

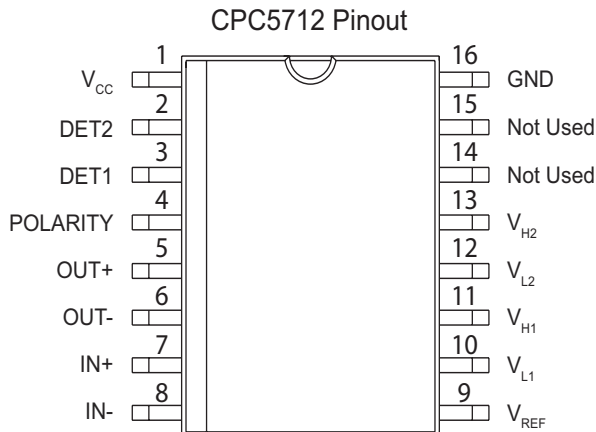

### 1.2 Pin Description

Pin	Name	Description
1	V <sub>CC</sub>	Supply Voltage
2	DET2	Output, Detector 2
3	DET1	Output, Detector 1
4	POLARITY	Output, represents polarity of input signal
5	OUT+	Output, amplifier non-inverting
6	OUT-	Output, amplifier inverting
7	IN+	Input, amplifier non-inverting
8	IN-	Input, amplifier inverting
9	V <sub>REF</sub>	Output, Reference used to set threshold levels
10	V <sub>L1</sub>	Input, sets DET1 low voltage detection threshold
11	V <sub>H1</sub>	Input, sets DET1 high voltage detection threshold
12	V <sub>L2</sub>	Input, sets DET2 low voltage detection threshold
13	V <sub>H2</sub>	Input, sets DET2 high voltage detection threshold
14	Not Used	Do not use, connect to ground
15	Not Used	Do not use, connect to ground
16	GND	Ground

### 1.3 Absolute Maximum Ratings

Parameter	Min.	Max.	Unit
V <sub>CC</sub>	-0.3	6.0	V
Storage temperature	-40	+125	°C
Power dissipation	-	50	mW

*Absolute maximum ratings are stress ratings. Stresses in excess of these ratings can cause permanent damage to the device. Functional operation of the device at conditions beyond those indicated in the operational sections of this data sheet is not implied.*

### 1.4 Recommended Operating Conditions

Parameter	Symbol	Min.	Max.	Units
V <sub>CC</sub>	V <sub>CC</sub>	3.0	5.5	V
Input Common Mode Current <sup>1</sup>	I <sub>CM</sub>	-	12	μA
V <sub>REF</sub> Loading <sup>2</sup>				
Resistive	R <sub>REF</sub>	20	1000	kΩ
Capacitive	C <sub>REF</sub>	-	220	pF
OUT+ and OUT- Loading				
Capacitive	C <sub>OUT</sub>	C <sub>OUT</sub>	300	pF
Current	I <sub>OUT</sub>	-500	+500	μA
Operating Temperature	T <sub>A</sub>	-40	+85	°C

<sup>1</sup> Input common-mode current per pin must not exceed limit.

<sup>2</sup> Resistive and Capacitive loads on the V<sub>REF</sub> output must remain within these limits.

## 1.5 Electrical Characteristics

Unless otherwise specified, minimum and maximum values are guaranteed by production testing.

Typical values are characteristic of the device at 25°C and are the result of engineering evaluations. They are

provided for informational purposes only and are not part of the manufacturing testing requirements.

Unless otherwise noted, all electrical specifications are listed for  $T_A=25^\circ\text{C}$  and  $V_{CC} = 3\text{V to }5.5\text{V}$ .

Parameter	Conditions	Symbol	Min.	Typ.	Max.	Units
<b>DC Characteristics</b>						
Supply Voltage		$V_{CC}$	3	-	5.5	V
Supply Current	$V_{CC}=3\text{V}$	$I_{CC}$	1.1	1.42	1.9	mA
	$V_{CC}=5.5\text{V}$		1.5	1.72	2.4	
<b>AC Characteristics</b>						
Input Impedance		$R_{IN-DIFF}$	10	-	-	$\text{M}\Omega$
Output Offset Voltage	From IN+/IN- to OUT+/OUT-	-	-5	-	5	mV
Output Offset Voltage	From IN+/IN- through to the comparators	-	-20	-	20	mV
Input Offset Current	$I_{CM}=0\mu\text{A}$	$I_{IO}$	-45	-	45	nA
	$I_{CM}=12\mu\text{A}$	$I_{IO}$	-125	-	125	nA
Reference Voltage	$I_{REF}=0\mu\text{A}$ ,	$V_{REF}$	1.4	1.5	1.6	V
Common-Mode Rejection Ratio	Using application circuit with common-mode current $\leq 12\mu\text{A}$ , 0-120 Hz	CMRR	55	-	-	dB
Differential Gain	0-20kHz	-	4.85	5.00	5.15	-
<b>Polarity Detection Characteristics</b>						
Polarity Detection Threshold Voltage	Differential signal applied to IN+ and IN-	$V_{IN}$	$\pm 22$	$\pm 37$	$\pm 54$	mV
<b>Digital Output Characteristics</b>						
Output Voltage, High	$I_{OH}=-5\text{mA}$	$V_{OH}$	$V_{CC}-0.6$	-	-	V
Output Voltage, Low	$I_{OL}=5\text{mA}$	$V_{OL}$	-	-	0.4	V

## 2. Functional Description

### 2.1 Overview

Clare's CPC5712 is a generalized building block IC for telephone systems that is connected, through a resistor network, to the TIP and RING leads. From the TIP and RING line voltage, the CPC5712 provides a buffered and amplified differential linear representation output voltage, a polarity detect signal, and two programmable level detect signals. From these detected levels, certain line conditions can be inferred such as Line-In-Use and battery presence. The CPC5712 provides TTL/CMOS compatible outputs for the polarity and programmable level detectors.

The polarity detect and the two programmable level detects all incorporate hysteresis to provide noise immunity and eliminate rapid output state changes in the presence of large voice signals. Hysteresis settings for the two programmable level detects are independently programmable; however, the polarity hysteresis is internally fixed.

The high and low thresholds of the two programmable level detectors are set with external resistors, the selection of which is described below.

Positive polarity, POLARITY = HIGH, is indicated for an OUT+ level greater than the OUT- level while negative polarity is indicated for an OUT+ level less than OUT-. For a logic-high polarity detect output with a normal battery feed of TIP more positive than RING, the amplifier IN+ will need to be connected to the TIP lead via the high impedance input resistors. Detection and hysteresis thresholds for polarity are internal to the device.

The CPC5712 is connected to the TIP/RING interface through a high-impedance resistor divider to attenuate the signal. The resistors in the divider network become a distributed resistive isolation barrier between the high-voltage line side and the low voltage side. The attenuator and the CPC5712 present a high impedance to TIP and RING, making the circuit almost undetectable when used as a monitoring device.

### 2.2 Line Side Interface

**IN+, IN-:** Analog inputs. The differential signal across these inputs is amplified and brought out to the pins OUT+ and OUT-. A nominal reference voltage bias of 1.5V is applied to IN+ and IN- by circuitry internal to the chip. Because the voltage across TIP and RING can be very large, TIP and RING cannot be directly connected to IN+ and IN-. A resistor divider network

defined by  $R_{IN1}$ ,  $R_{IN2}$  and  $R_{DIFF}$  attenuates the high voltage signal across TIP and RING (see [Figure 1](#)). The resulting low voltage differential signal across  $R_{DIFF}$  is applied to the inputs IN+ and IN-. Resistors  $R_{IN1}$ ,  $R_{IN2}$  and  $R_{DIFF}$  are external resistors that must be supplied by the user.

Any component sizing and value recommendations given in the circuits described in this document will need to be reviewed with regard to the regulatory and safety requirements for each particular application. For example, the resistors selected for  $R_{IN1}$  and  $R_{IN2}$ , shown in [Figure 1](#), are recommended to be a pair of 1206 surface mount size resistors in series to provide for high-voltage isolation.

### 2.3 Monitor Output

**OUT+, OUT-:** Analog outputs. The differential signal across these outputs is the same as the differential input signal, except there has been a differential gain of 5 applied to it. A nominal reference voltage bias of 1.5V is applied to OUT+ and OUT- by circuitry internal to the chip.

### 2.4 Detector Outputs

**DET2, DET1, POLARITY:** Digital outputs. These signals show whether threshold 2 has been crossed, threshold 1 has been crossed, and the polarity of the TIP to RING potential.

When configured as shown in [Figure 1](#), POLARITY will be high after the TIP to RING potential (TIP more positive than RING) has increased to a nominal 2V. POLARITY will switch low after the TIP to RING voltage decreases to approximately -2V. For example, if the TIP to RING voltage starts at -48V, POLARITY will be low. As the TIP to RING voltage increases to +1V, POLARITY will remain low. As the TIP to RING voltage increases beyond its internally set positive threshold, the POLARITY output will switch high. POLARITY will remain high until the TIP to RING voltage decreases below its internally set negative threshold. Because these polarity thresholds are set internally they are not user adjustable.

In the case of the detector 2 switching points, DET2 will be low after the |TIP/RING| voltage has decreased below a threshold set at  $V_{L2}$ . DET2 will not transition high until after the |TIP/RING| voltage has increased above a threshold set at  $V_{H2}$ . This |TIP/RING| voltage

will be larger than the threshold set at  $V_{L2}$ . As an example, the voltage at  $V_{L2}$  represents a |TIP/RING| threshold of 20V and  $V_{H2}$  represents a TIP/RING threshold of 22V. DET2 will be low if the |TIP/RING| voltage decreases below 20V, and it will remain low until the |TIP/RING| voltage increases above 22V. DET2 will change states for both positive and negative values of TIP/RING voltage as represented by |TIP/RING|. This means that DET2 will also be low if the TIP/RING voltage decreases below -20V and will remain low until the TIP/RING voltage increases beyond -22V. The user must rely on POLARITY to determine whether the TIP/RING threshold changed due to a positive or negative differential signal since DET2 does not contain any polarity information.

DET1 behaves similarly to DET2, except that it is triggered based on the voltage set at  $V_{L1}$  and  $V_{H1}$ . This means that DET1 will be low after the |TIP/RING| voltage has decreased below the value set by the voltage at  $V_{L1}$  and will not change high until after the |TIP/RING| voltage has increased above the value set by the voltage at  $V_{H1}$ . DET1 does not give any polarity information for the same reasons as defined for DET2. In the application circuit provided, the TIP/RING threshold levels of DET2 will always be higher than the threshold levels of DET1.

## 2.5 Detector Threshold Operation

**$V_{L1}$ ,  $V_{H1}$ ,  $V_{L2}$ , and  $V_{H2}$ :** Inputs used to set the |TIP/RING| threshold levels that are to be detected.  $V_{H1}$  and  $V_{L1}$  are used to set the high and low threshold levels. The difference between  $V_{H1}$  and  $V_{L1}$  sets the hysteresis for the 1<sup>st</sup> threshold level.  $V_{H2}$  and  $V_{L2}$  are used to set the threshold and hysteresis for the 2<sup>nd</sup> threshold level. There is a digital output for both the 1<sup>st</sup> and 2<sup>nd</sup> threshold levels that shows when the |TIP/RING| voltage has crossed a threshold level and when it has exceeded the configured hysteresis level. This was explained in the DET1 and DET2 definitions. In general, the digital output will be low when the |TIP/RING| voltage has fallen below the  $V_{L\#}$  level and will change high again once the |TIP/RING| voltage has risen above the  $V_{H\#}$  level.

**$V_{REF}$ :** An analog output that is similar to the DC bias level that is applied to OUT+ and OUT-. This voltage is brought off chip so that it can be used to define threshold detection levels. Load capacitance on this pin must be kept less than the value recommended in the table **Recommended Operating Conditions**. The total load resistance on this pin must be within the

range specified in the table **Recommended Operating Conditions**.

Resistors R1, R2, R3, R4 and R5 are external resistors, which must be provided by the user. The selection of the resistors determines the voltages at  $V_{L2}$ ,  $V_{H2}$ ,  $V_{L1}$  and  $V_{H1}$  and therefore the threshold and hysteresis values for the 2 detectors.

The values for R1, R2, R3, R4, and R5 are easily determined. Select voltage levels for the 1<sup>st</sup> and 2<sup>nd</sup> threshold and hysteresis settings such that:

$$V_{H2} > V_{L2} > V_{H1} > V_{L1}$$

Then use the following algorithm to find the values of R2, R3, R4 and R5.

1. Select a value for R1.
2.  $R2 = (R1(V_{H1} - V_{L1})) / V_{L1}$
3.  $R3 = (R1(V_{L2} - V_{H1})) / V_{L1}$
4.  $R4 = (R1(V_{H2} - V_{L2})) / V_{L1}$
5.  $R5 = (R1(V_{REF}/A - V_{H2})) / V_{L1}$ 
  - $V_{REF} = 1.5V$
  - $A = (2.5 (R_{DIFF})) / (R_{IN1} + R_{IN2} + R_{DIFF})$ , which typically calculates to 0.05; in this case: 0.04938. See **Figure 2**.

Also, as shown in the table of **Recommended Operating Conditions**, the resistive load on the  $V_{REF}$  pin must fall within the range:

$$20k\Omega < (R1 + R2 + R3 + R4 + R5) < 1M\Omega$$

## 2.6 Power Connections

**VCC, Ground:** Power supply pins. These are used to supply voltage and ground to the chip.

### 3. Design Example

An application circuit that is based on information discussed in [Section 2.5 “Detector Threshold Operation”](#) on page 6 is shown in [Figure 2](#).

In the following telephony design example, it is desired to have a Line-In-Use (LIU) detector set at 12V with a hysteresis of 3V, and a loop or battery-presence (LOOP) detector set at 5V with a hysteresis of 2V. The

LIU detector will monitor the Public Switched Telephone Network (PSTN) twisted pair TIP and RING leads for a voltage level that indicates a device on the line is off-hook while the LOOP detector monitors for the presence of battery feed. In this example detector 2 (DET2) will be the LIU detector as it has the greater voltage detect thresholds.

**Figure 2 CPC5712 Application Circuit**

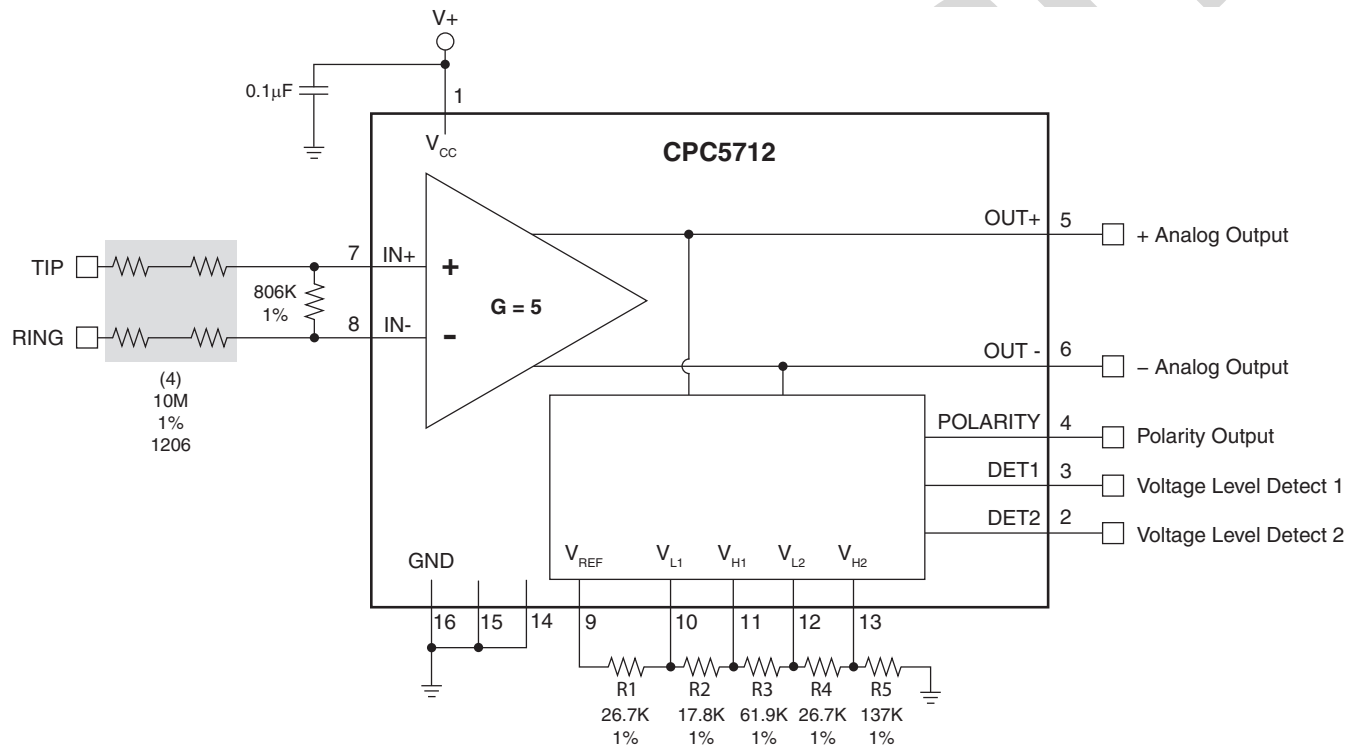

#### 3.1 Line Interface

Between the CPC5712 and the TIP/RING line is a high impedance resistive divider network that provides sufficient impedance to meet the barrier insulation specifications in safety regulations and comply with the on-hook DC leakage to ground requirements from the various network compatibility specifications.

From the individual TIP and RING leads to the IN+ and IN- are two series 10MΩ resistors. Note that for most applications, the recommended standard size of the surface-mount input resistor divider is 1206.

In practice, each 1206-size resistor is capable of withstanding 2000V peak waveforms typical of lightning surges on the phone line. Hence, two 1206 resistors can withstand 4000V lightning pulses.

### 3.2 Voltage Detector Design

From the application requirements given above, the desired  $\overline{L}U$  detector threshold voltages are therefore:

- $V_{H2} = 15V$
- $V_{L2} = 12V$

and the detector thresholds for the LOOP detector are:

- $V_{H1} = 5V$
- $V_{L1} = 3V$

#### 3.2.1 Calculate Resistor Values

From the design equations provided in [Section 2.5 “Detector Threshold Operation” on page 6](#) this gives:

- $R1=R1$
- $R2=0.666667 R1$
- $R3=2.333333 R1$
- $R4=R1$
- $R5=5.125558 R1$

Summing these equations provides the following result:

$$R1+R2+R3+R4+R5 = 10.12556 R1$$

and since this sum is bound by:

$$20k\Omega < (R1 + R2 + R3 + R4 + R5) < 1M\Omega$$

this reduces to:  $20k\Omega < (10.12556 R1) < 1M\Omega$ .

Taking into account the additional constraint of resistor tolerance, 1% in this example, the range of allowable values for R1 is further reduced and becomes:

$1.995k\Omega < R1 < 97.782k\Omega$  permitting a value for R1 to be chosen.

Selecting a standard value from the E96, 1% table for R1 of 26.7k $\Omega$ , the calculated values for the remaining resistors becomes:

- $R2=17.8k\Omega$
- $R3=62.3k\Omega$
- $R4=26.7k\Omega$
- $R5=136.85k\Omega$

Since the calculated values of R3 and R5 are not standard values, a reasonable compromise for these resistors is:  $R3=61.9k\Omega$  and  $R5=137k\Omega$ . See [Figure 2](#).

#### 3.2.2 Verify Resistor Selection

Once the resistor values are chosen it is necessary to back calculate the nominal detector thresholds.

To do this the following equations are provided for two variables:

$$R_{\Sigma} = R_{IN1} + R_{IN2} + R_{DIFF}$$

$$R_{REF} = R1 + R2 + R3 + R4 + R5$$

where  $R_{\Sigma}$  is the sum of the resistive interface network and  $R_{REF}$  is the sum of the resistor divider network on the reference voltage output.

The following values are also needed to perform the threshold calculations. They are:

- $V_{REF} = 1.5V$
- $R_{IN1} = R_{IN2} = 2 \times 10M\Omega = 20M\Omega$
- $R_{DIFF} = 806k\Omega$
- $G=2.5$

which gives:

- $R_{\Sigma} = 40.806M\Omega$  and
- $R_{REF} = 270.1k\Omega$

The threshold equations are:

$$1. \quad V_{L1} = \frac{V_{REF} \cdot R_{\Sigma} \cdot R1}{G \cdot R_{DIFF} \cdot R_{REF}}$$

$$2. \quad V_{H1} = \frac{V_{REF} \cdot R_{\Sigma} \cdot (R1 + R2)}{G \cdot R_{DIFF} \cdot R_{REF}}$$

$$3. \quad V_{L2} = \frac{V_{REF} \cdot R_{\Sigma} \cdot (R1 + R2 + R3)}{G \cdot R_{DIFF} \cdot R_{REF}}$$

$$4. \quad V_{H2} = \frac{V_{REF} \cdot R_{\Sigma} \cdot (R1 + R2 + R3 + R4)}{G \cdot R_{DIFF} \cdot R_{REF}}$$

Using the selected standard 1% resistor values, and back calculating to the threshold voltages produces these results:

- $V_{L1} = 3.00280V$
- $V_{H1} = 5.00467V$
- $V_{L2} = 11.9662V$
- $V_{H2} = 14.9690V$

As can be seen, the error from using standard value resistors is less than 0.1% for  $V_{L1}$  and  $V_{H1}$  and is less than 0.3% for  $V_{L2}$  and  $V_{H2}$ .



## 4. Manufacturing Information

### 4.1 Mechanical Dimensions and Printed Circuit Board Land Pattern

#### 16-Lead QSOP Package

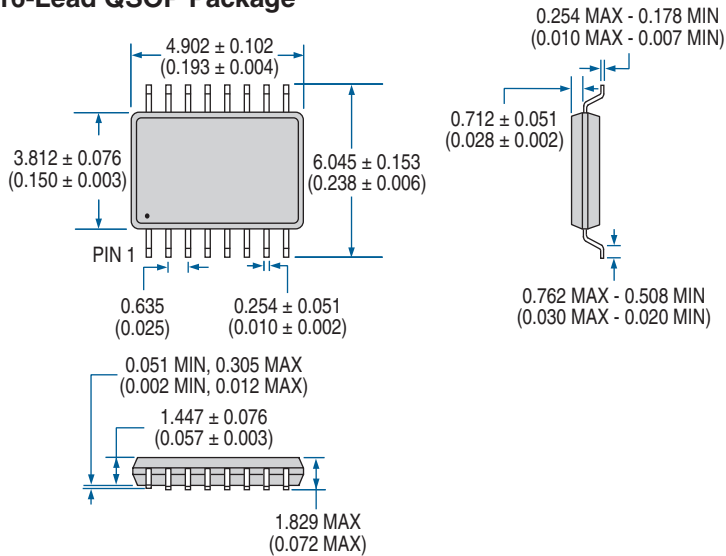

#### Recommended PCB Land Pattern

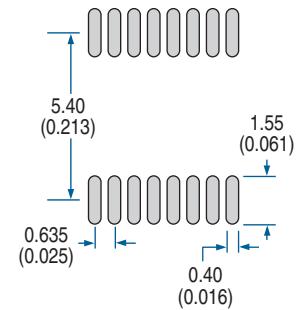

Dimensions  
mm  
(inches)

### 4.2 Tape and Reel Packaging

#### Tape and Reel Packaging for 16-Lead QSOP Package

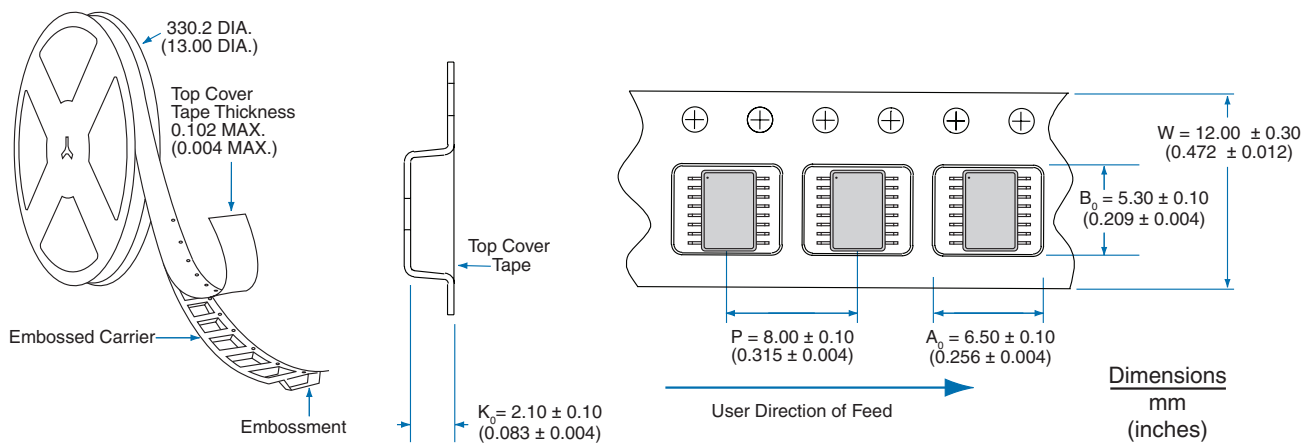

NOTE: Tape dimensions not shown comply with JEDEC Standard EIA-481-2

### 4.3 Soldering

For proper assembly, the component must be processed in accordance with the current revision of IPC/JEDEC standard J-STD-020. Failure to follow the recommended guidelines may cause permanent damage to the device resulting in impaired performance and/or a reduced lifetime expectancy.

### 4.4 Washing

Clare does not recommend ultrasonic cleaning or the use of chlorinated hydrocarbons.



**For additional information please visit our website at: [www.clare.com](http://www.clare.com)**

Clare, Inc. makes no representations or warranties with respect to the accuracy or completeness of the contents of this publication and reserves the right to make changes to specifications and product descriptions at any time without notice. Neither circuit patent licenses nor indemnity are expressed or implied. Except as set forth in Clare's Standard Terms and Conditions of Sale, Clare, Inc. assumes no liability whatsoever, and disclaims any express or implied warranty, relating to its products including, but not limited to, the implied warranty of merchantability, fitness for a particular purpose, or infringement of any intellectual property right.

The products described in this document are not designed, intended, authorized or warranted for use as components in systems intended for surgical implant into the body, or in other applications intended to support or sustain life, or where malfunction of Clare's product may result in direct physical harm, injury, or death to a person or severe property or environmental damage. Clare, Inc. reserves the right to discontinue or make changes to its products at any time without notice.

Specification: DS-CPC5712-R00G  
©Copyright 2008, Clare, Inc.  
All rights reserved. Printed in USA.  
4/21/08