

Features

Character Format5x7 Dots with Cursor
 ConnectionPin
 Options.....TN or STN reflective or transfective polarizer
 Characters.....240 in ROM, 8 user designed in RAM

Physical Data

Module Size.....65.0W x 27.7H x 2.1T mm
 Viewing Area Size.....61.0W x 15.7H mm
 Character Size.....2.95W x 4.50H mm
 Weight.....7.0 g

Block Diagram

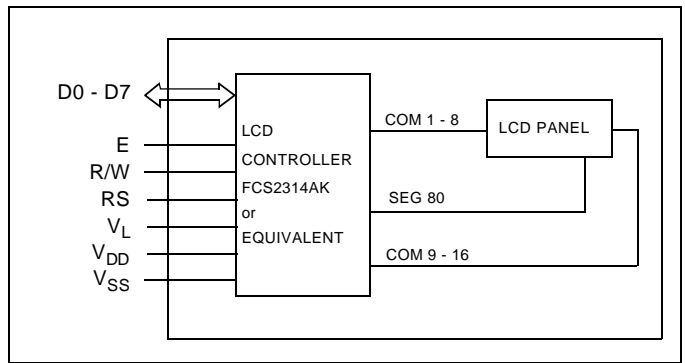

Absolute Maximum Ratings

PARAMETER	SYMBOL	MIN	MAX	UNIT
SUPPLY VOLTAGE	$V_{DD}-V_{SS}$	-0.3	6.0	V
SUPPLY VOLTAGE FOR LCD	$V_{DD}-V_L$	3	V_{DD}	V
INPUT VOLTAGE	V_{IN}	V_{SS}	V_{DD}	V
OPERATING TEMPERATURE	T_{OP}	0	50	°C
STORAGE TEMPERATURE	T_{STG}	-20	70	°C

Electrical Characteristics (VDD=5.0±0.25V 25°C)

PARAMETER	SYM	CONDITION	MIN	TYP	MAX	UNIT
INPUT HIGH VOLTAGE	V_{IH}	-	$0.7V_{DD}$	-	V_{DD}	V
INPUT LOW VOLTAGE	V_{IL}	-	V_{SS}	-	$0.2V_{DD}$	V
OUTPUT HIGH VOLTAGE	V_{OH}	$I_{OH}=0.2mA$	$0.8V_{DD}$	-	V_{DD}	V
OUTPUT LOW VOLTAGE	V_{OL}	$I_{OL}=1.2mA$	V_{SS}	-	$0.2V_{DD}$	V
POWER SUPPLY CURRENT	I_{DD}	$V_{DD}=5.0V$	-	1.1	2.5	mA
POWER SUPPLY FOR LCD	$V_{DD}-V_L$	$T_A=25°C$	-	4.4	-	V
DRIVE METHOD	1/16 Duty					

Pin Connections

PIN NO.	SYMBOL	LEVEL	FUNCTION	
1	RS	H/L	H: Data input L: Instruction data input	
2	R/W	H/L	H: Data read L: Data write	
3	E	L→H→L	Enable signal	
4	D0	H/L	Data bus	
5	D1	H/L		
6	D2	H/L		
7	D3	H/L		
8	D4	H/L		
9	D5	H/L		
10	D6	H/L		
11	D7	H/L	Power supply	
12	V_{SS}	0V		
13	V_{DD}	5V	5V	
14	V_L	~ +0.6V	Contrast control	