

B313M27N0**

SERIES _____
 B31= FORM A
 POLES _____
 2= 2 POLE & 3= 3 POLE
 THREAD FIXING SIZE _____
 P09= PG9 THREAD, P11= PG11 THREAD, P14= PG13.5 THREAD
 M27= M27x1.5 THREAD LOCK RING WITHOUT COVER HOUSING
 MATERIAL AND HOUSING COLOUR _____
 G= PA6 GRAY, N= PA6 BLACK, W= PA6 BLACK V0, T= TRANSPARENT
 SCREW AND GASKET _____
 0= NO SCREW, NO GASKET
 NON STANDARD COMPONENTS _____

NOTES
 1. PLEASE SEE TABLE FOR CURRENTLY CONFIGURED PART NUMBERS.
 FOR SPECIFIC PART NUMBERS PLEASE CONTACT SALES OR CONSULT
 THE INTELLIGENT PART NUMBERS IN THE TABLE ATTACHED.
 3. FOR PACKAGING SEE PACKAGING SPEC PK-121013-B31
 4. PRODUCT SPEC: SEE PS-121201-001
 4. TERMINALS BENT AFTER INSERTION FOR BEND ANGLE SEE TABLE

LAST INSPECTION NUMBER 4

VERSION A

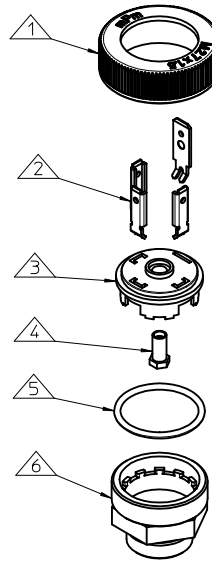

VERSION B

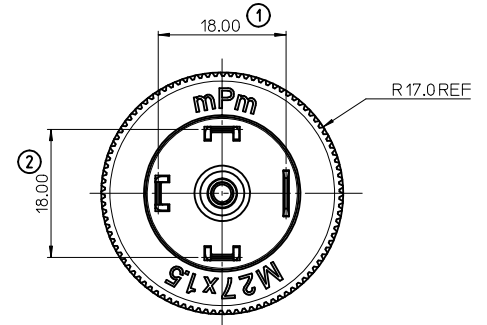
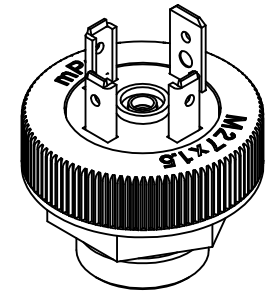
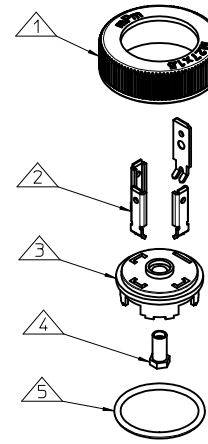

ITEM	DESCRIPTION
1	LOCK RING
2	TERMINALS
3	BASE HOUSING
4	INSERT
5	GASKET
6	COVER HOUSING

PART No.	mPm PART No.	DESCRIPTION	TERMINAL BEND ANGLE (°)	VERSION
1210120116	B312M27N0	TYPE A 2P BLACK, M27 THREAD	90	B
1210120117	B312P09N0	TYPE A 2P BLACK, PG9 THREAD	90	A
1210120118	B312P11N0	TYPE A 2P BLACK, PG11 THREAD	90	A
1210120119	B312P14N0	TYPE A 2P BLACK, PG13.5 THREAD	90	A
1210120120	B313M27N0	TYPE A 3P BLACK, M27 THREAD	90	B
1210120121	B313P09N0	TYPE A 3P BLACK, PG9 THREAD	90	A
1210120122	B313P11N0	TYPE A 3P BLACK, PG11 THREAD	90	A
1210120123	B313P14N0	TYPE A 3P BLACK, PG13.5 THREAD	90	A

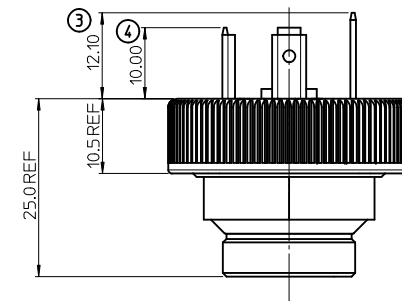

ADDED VIEW EC NO: IPG2012-0674 DRWNG: SHEA 2012/04/10 CHKD: SMC GREVY 2012/04/11 APPR: EFO LAN 2012/04/19 DESCRIPTION	QUALITY SYMBOLS ▽=0 ▽=0	GENERAL TOLERANCES (UNLESS SPECIFIED) <table border="1"> <thead> <tr> <th></th> <th>mm</th> <th>INCH</th> </tr> </thead> <tbody> <tr> <td>4 PLACES</td> <td>± ---</td> <td>± ---</td> </tr> <tr> <td>3 PLACES</td> <td>± ---</td> <td>± ---</td> </tr> <tr> <td>2 PLACES</td> <td>± 0.1</td> <td>± ---</td> </tr> <tr> <td>1 PLACE</td> <td>± 0.2</td> <td>± ---</td> </tr> <tr> <td colspan="3">ANGULAR ± ---°</td> </tr> </tbody> </table>		mm	INCH	4 PLACES	± ---	± ---	3 PLACES	± ---	± ---	2 PLACES	± 0.1	± ---	1 PLACE	± 0.2	± ---	ANGULAR ± ---°			DIMENSION STYLE MM ONLY	SCALE 2:1	DESIGN UNITS METRIC	THIRD ANGLE PROJECTION
		mm	INCH																					
	4 PLACES	± ---	± ---																					
	3 PLACES	± ---	± ---																					
2 PLACES	± 0.1	± ---																						
1 PLACE	± 0.2	± ---																						
ANGULAR ± ---°																								
DRAWN BY JOCONNOR	DATE 2011/06/27	TITLE B31 SERIES BASE																						
CHECKED BY DMAHER	DATE 2011/06/27																							
APPROVED BY EFO LAN	DATE 2011/07/21	MOLEX INCORPORATED																						
MATERIAL NO. SEE CHART	DOCUMENT NO. SD-121012-008	SHEET NO. 1 OF 1																						
DRAFT WHERE APPLICABLE MUST REMAIN WITHIN DIMENSIONS																								
THIS DRAWING CONTAINS INFORMATION THAT IS PROPRIETARY TO MOLEX INCORPORATED AND SHOULD NOT BE USED WITHOUT WRITTEN PERMISSION																								