

Amphenol LTW's New Crimp Termination Field Installable RBL Connector for Quick and Easy Installation

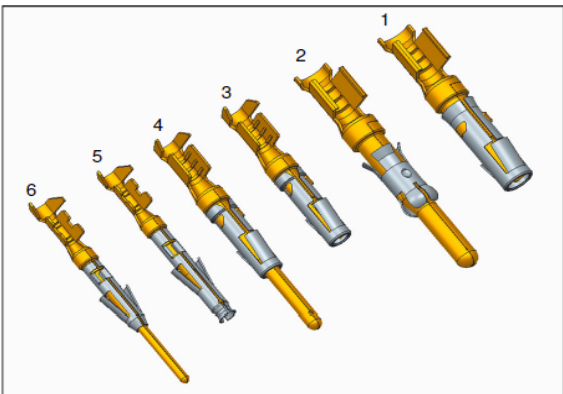

- IP 67 waterproof protection, 5A-20A, 300V AC/430V DC.
- User-friendly latch design locking mechanism with audible and tactile feedback.
- Error-free polarization key alignment.
- Designed for cable-to-cable & cable-to-panel interconnection
- Currently available in 4 pin (additional pin outs possible upon request)
- Suitable for a wide range of indoor and outdoor dust and water borne environments.



| Female Contacts | Fig. | Male Contacts | Fig. | Wire size | | Insulation Diameter(Max) |
|-----------------|------|---------------|------|-----------|-----------------|--------------------------|
| | | | | AWG | mm ² | |
| BBB00010139 | 1 | BBB00010138 | 2 | 14~12 | 2.5~3.5 | 4.3mm |
| BBB00010149 | 3 | BBB00010150 | 4 | 18~16 | 0.75~1.5 | 3.2mm |
| BBB00010151 | 5 | BBB00010152 | 6 | 22~20 | 0.35~0.5 | 2.6mm |

