



INPAQ

PRODUCT SPECIFICATION

DOCUMENT NO. ENS000114380

DESCRIPTION	DRAWN BY	DESIGNED BY	CHECKED BY	APPROVED BY
WMM1040DX Series	Amily	Scott	Wiley	LSC

WMM1040DX Series Engineering Specification

1. Scope

Feature

- Low RDC, high current handling inductor.
- Magnetically shielded structure that ensures the high-density mounting configurations.
- Flat bottom surface ensures secure, reliable mounting.
- Provided in embossed carrier tape packaging for use with automatic mounting machines.

Applications

- Ideally used in Notebook, SSD, PDA, DSC, DC-DC Converters, etc.

2. Explanation of Part Number

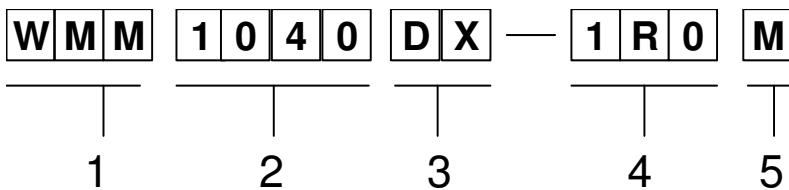

- ◆ 1 : Product Name, Wire-wound metal molding power inductor
- ◆ 2 : Dimensions
- ◆ 3 : Type Name
- ◆ 4 : Product type Inductance (μH)
- ◆ 5 : Model code: Inductance tolerance ($M_{\pm 20\%}$; $N_{\pm 30\%}$)

3. Construction & Dimensions

3.1. Shapes, Dimensions and Recommended Land Patterns

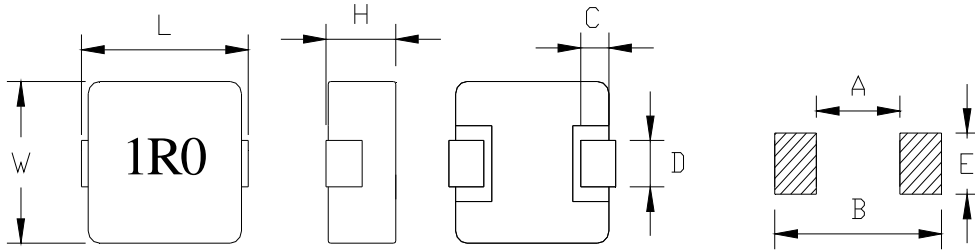

Series	L (mm)	W (mm)	H (mm)	C (mm)	D (mm)	Recommended Land Patterns		
						A' (mm)	B (mm)	E (mm)
WMM1040DX	11.2±0.3	10.0±0.3	4.0max	2.0±0.5	3.0±0.5	5.5	13.5	4.0

3.2. Marking

The inductor is marked with a 3-digit code (using ink for marking)

Example: 1R0 means 1.0μH



4. General specifications

4.1 Electrical Specifications

Part No.	Inductance	DC Resistance		Heating Rating Current	Saturation Current
	L0 (μH)	DCR (mΩ)		Idc (A)	Isat (A)
	±20 %, 100 kHz, 1V	TYP.	MAX.	TYP.	TYP.
WMM1040DX-R47M	0.47	2.5	3.0	21.00	35.00
WMM1040DX-R68M	0.68	3.0	3.3	18.00	29.00
WMM1040DX-1R0M	1.00	3.3	3.6	17.00	28.00
WMM1040DX-1R5M	1.50	4.7	5.6	15.00	21.00
WMM1040DX-2R2M	2.20	6.0	7.0	12.00	18.00
WMM1040DX-3R3M	3.30	10.8	11.8	10.00	16.00
WMM1040DX-4R7M	4.70	17.0	20.0	8.05	15.00
WMM1040DX-5R6M	5.60	20.0	23.0	8.00	14.00
WMM1040DX-6R8M	6.80	22.5	25.0	7.00	12.00
WMM1040DX-8R2M	8.20	25.0	27.0	6.50	9.00
WMM1040DX-100M	10.0	27.0	30.0	6.50	8.50
WMM1040DX-150M	15.0	40.0	45.0	6.30	7.00
WMM1040DX-220M	22.0	60.0	66.0	5.00	5.50
WMM1040DX-330M	33.0	85.0	92.0	4.00	4.50
WMM1040DX-470M	47.0	130.0	145.0	3.30	3.50
WMM1040DX-680M	68.0	178.0	195.0	2.30	3.00

Notes

1. All test data is referenced to 25 °C ambient
2. Operating temperature range - 40 °C to + 125 °C
3. Idc(A):DC current (A) that will cause an approximate ΔT of 40 °C(reference ambient temperature is 25°C)
4. Isat(A):DC current (A) that will cause L0 to drop approximately 30 %
5. The part temperature (ambient + temp rise) should not exceed 125 °C under worst case operating conditions.

5. Reliability and Test Conditions

5.1 Mechanical Reliability

Item	Specification and Requirement	Test Method
Solderability	The surface of terminal immersed shall be minimum of 90% covered with a new coating of solder	Solder heat proof : (1) Preheating : $160 \pm 10^{\circ}\text{C}$ 90s (2) Retention time: $245 \pm 5^{\circ}\text{C}$ for 3 ± 1 sec
Vibration	1) No mechanical damage. 2) Inductance change within $\pm 10\%$.	(1) Frequency : 10Hz to 55Hz to 10Hz in 60 sec as a period (2) Vibration time : period cycled for 2 hours in each of 3 mutual perpendicular directions (3) Amplitude: 1.5mm max.
Terminal strength	No detachment of terminal pin and no breakage of wire	Add static load 4.9N (500gf) to inductor through hole of test board for 10 ± 2 sec

5.2 Endurance Reliability

Item	Specification and Requirement	Test Method
Thermal Shock	1) No mechanical damage. 2) Inductance change within $\pm 10\%$.	1. Repeat 100 cycles as follow: - $40 \pm 2^{\circ}\text{C}$; 30 ± 3 mins → Room temp., 5 mins → $+125 \pm 2^{\circ}\text{C}$, 30 ± 3 mins → Room temp., 5 mins 2. Recovery: $48 + 4 / -0$ hours of recovery under the standard condition after the test.
High Temperature Resistance	1) No mechanical damage. 2) Inductance change within $\pm 10\%$.	1. Environment condition: $85 \pm 2^{\circ}\text{C}$ Applied Current: Rated current 2. Duration: $500 + 4 / -0$ hours
Humidity Resistance	1) No mechanical damage. 2) Inductance change within $\pm 10\%$.	1. Environment condition: $60 \pm 2^{\circ}\text{C}$ Humidity: 90–95% Applied Current: Rated current 2. Duration: $500 + 4 / -0$ hours
High/Low Temperature Storage	1) No mechanical damage. 2) Inductance change within $\pm 10\%$.	Store temperature: High: $+125 \pm 2^{\circ}\text{C}$, $500 + 4 / -0$ hours Low: $-40 \pm 2^{\circ}\text{C}$, $500 + 4 / -0$ hours

6. Taping Package and Label Marking

6.1 Dimension of Tape (Unit: mm)

Series	W	P	F
WMM1040DX	24.0±0.3	16.0±0.1	11.5±0.1

6.2 Dimension of Reel (Unit: mm)

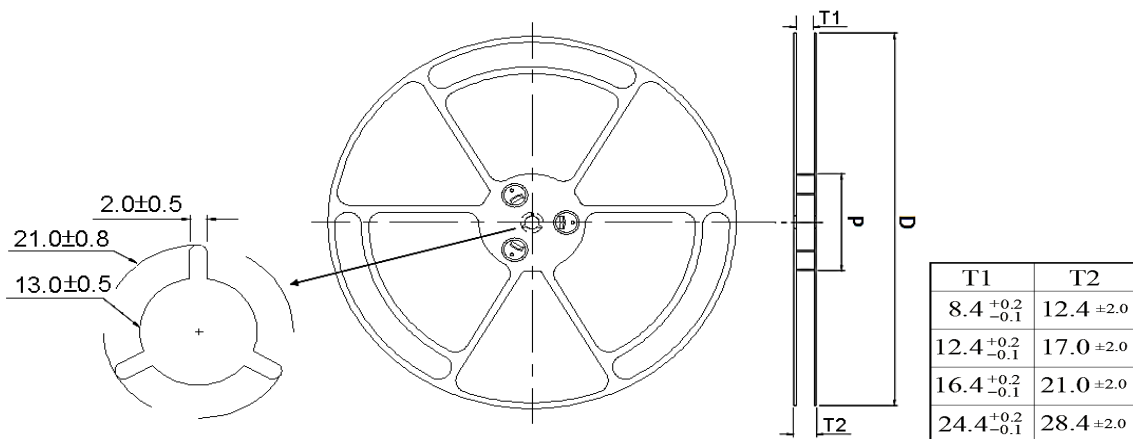

Code	D	P	Quantity(pcs)
Dimensions	330 ± 1.5	100 ± 1.5	800

Unit : mm

6.3 Peeling Strength of Cover Tape:

The peel force of top cover tape shall be between 0.10N to 1.3N

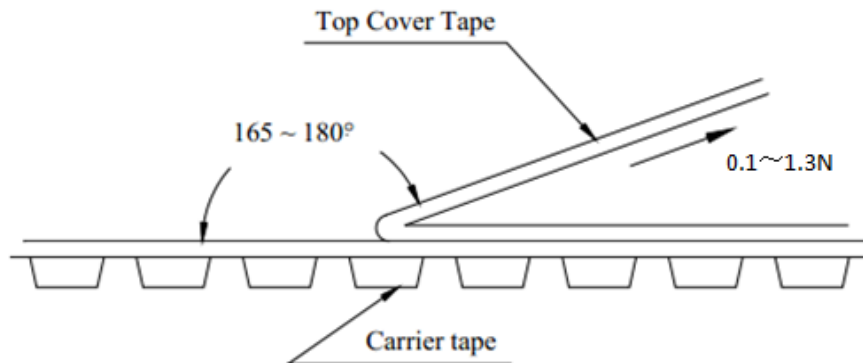

Room Temp.(°C)	Room Humidity (%)	Room aim (hpa)	Peel Speed (Mm/min)
5-35	45-85	860-1060	300

6.4 Taping Specifications

There shall be the portion having no product in both the head and the end of taping, and there shall be the cover tape in the head of taping.

6.5 Label Marking

The label specified as follows shall be put on the side of reel.

- (1) Part No.
- (2) Quantity
- (3) Lot No.

* Part No. And Quantity shall be marked on outer packaging.

7. Recommendable Reflow Soldering

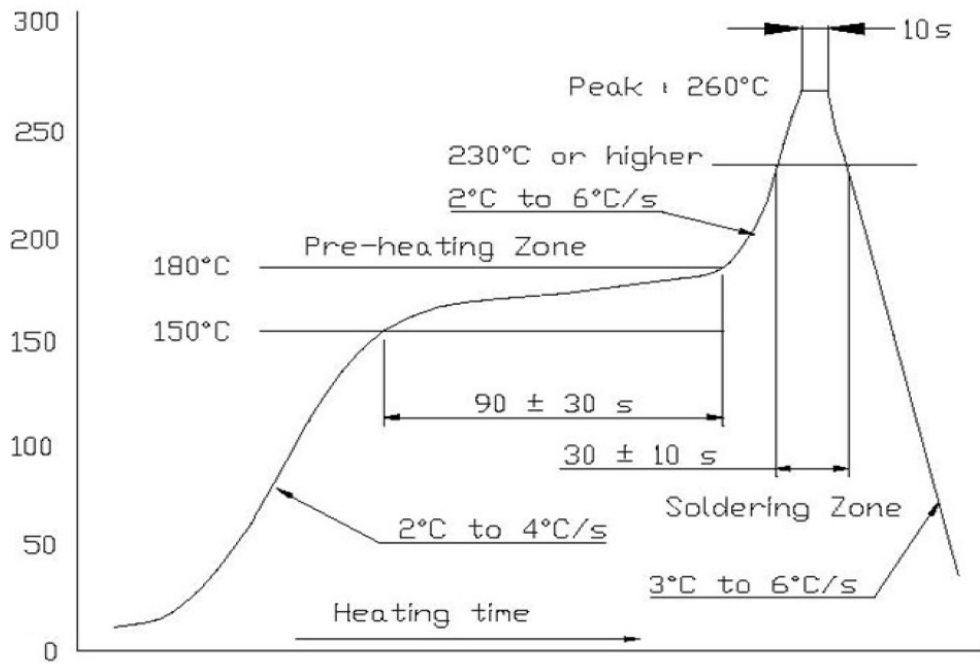

8. Precaution

8.1 Handling

- Keep the products away from all magnets and magnetic objects.
- Be careful not to subject the products to excessive mechanical shocks.
- Please avoid applying impact to the products after mounted on pc board.
- Avoid ultrasonic cleaning

8.2 Storage

To prevent deterioration of the solderability of terminal electrodes and/or the packing materials of the products, please store the products under following storage conditions.

Ambient temperature range +5 °C to 35°C

Humidity 45% to 70% RH .

Even under the ideal storage conditions, solder ability of inductor's electrode deteriorates as time passes, so inductors should be used within 6 months after the delivery time.